

**PART CATALOGUE**  
**ГЩС-515А**  
**TIRE CHANGER**

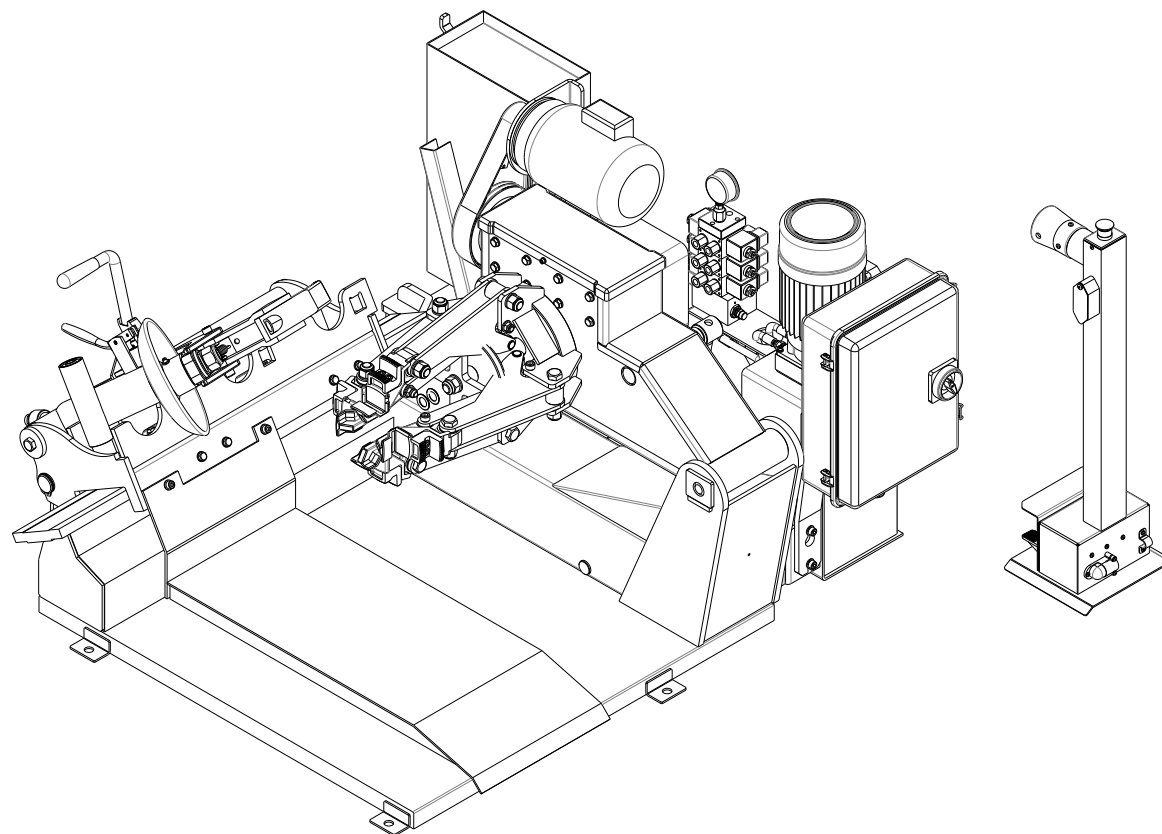

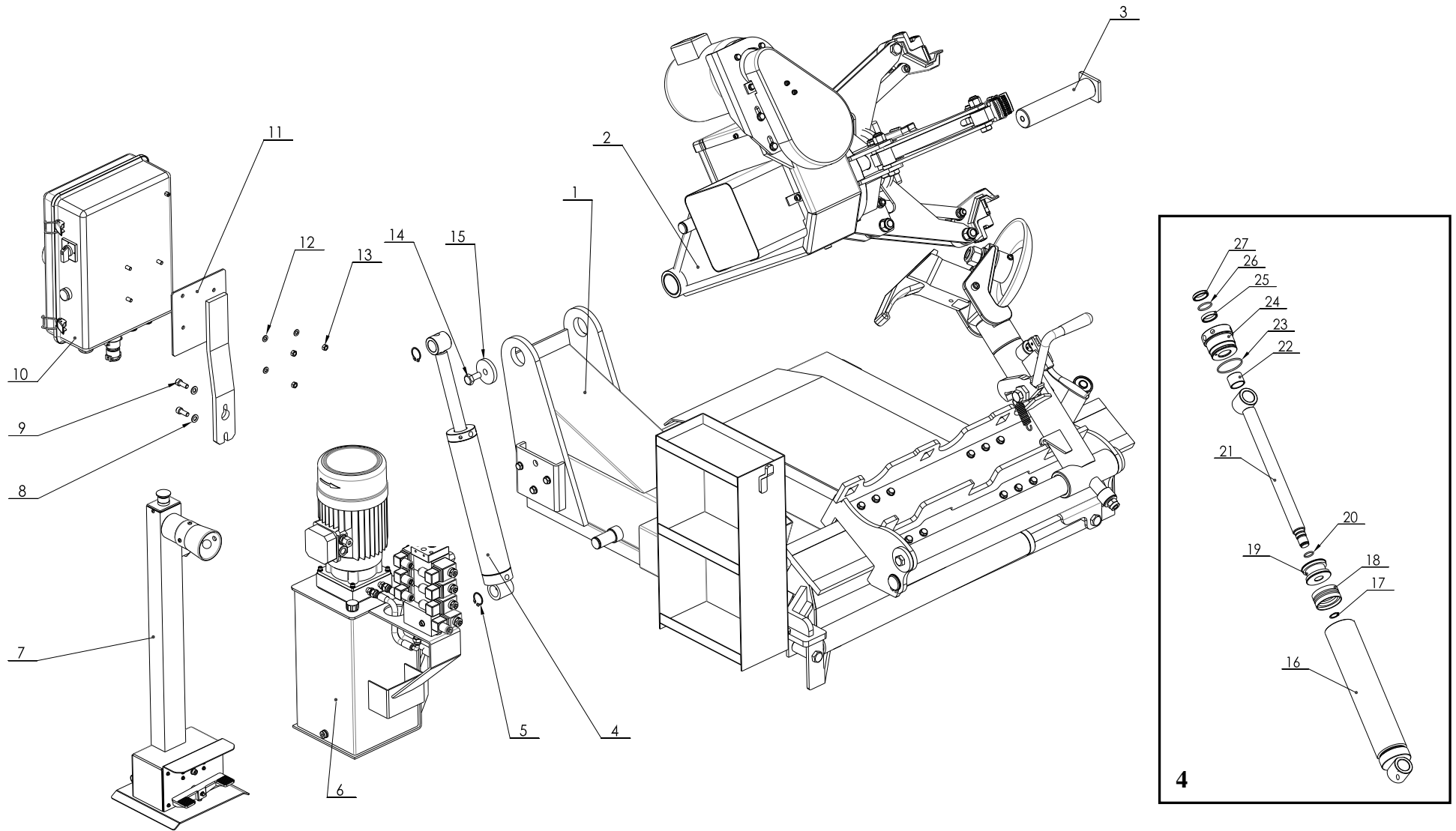



TAV.0	GENERAL ASSEMBLY	ED. 10/11
-------	------------------	-----------

ITEM	PART NO.	DESCRIPTION	QTY	REMARK
1	CC-800000	Frame	1	
2	CC-310000B	Self-centering chuck	1	
3	CC-380100	Bead breaking arm pin	1	
4	C-2C120-63-0	Arm cylinder	1	
5	0212021	Seeger D.30 - GB/T894.1	2	
6	302-BZ-0	Hydraulic unit	1	
7	YC8-2002000	Pedal control	1	
8	0205011	Washer D.10 - GB/T97.1	2	
9	0202062	Screw M10X25 - GB/T70.1	2	
10	S551-00C	Electric unit	1	
11	CC-850100	Panel support	1	
12	0205008	Washer D.8 - GB/T97.1	3	
13	0203008	Nut M8 - GB/T6170	3	
14	0201151	Screw M14X30 - GB/T5781	1	
15	CC-201009	Washer	1	
16	C-2C120-63-10	Cylinder liner	1	
17	0212005	Seeger D.20 - GB/T 894.1	1	
18	0312012	Gasket 63X47	1	
19	C-2C120-63-3	Piston	1	
20	0309022	O-ring 24X3.1 - GB1235	1	
21	C-2C120-63-4	Cylinder shaft	1	
22	0305006	Guide ring 30X25X2.5 - GB/T15242.2	1	
23	0309035	O-ring 63X3.1 - GB1235	1	
24	C-2C120-63-5	Cylinder guide cover	1	
25	0310009	Sealing ring 30X38X7	1	
26	0309080	O-ring 35X3.1 - GB1235	1	
27	0311005	Scraper D.30	1	

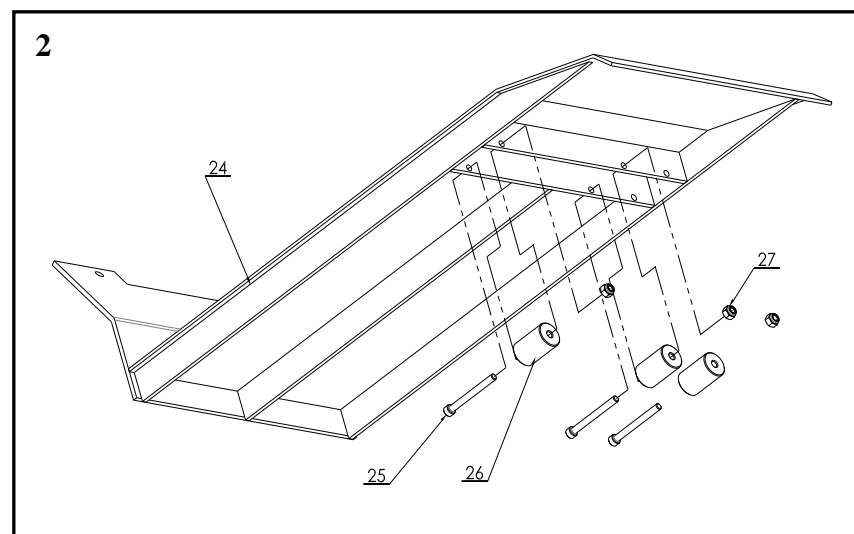
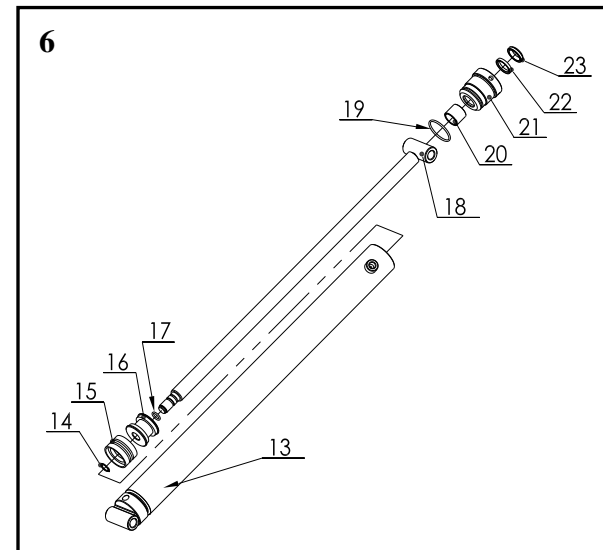
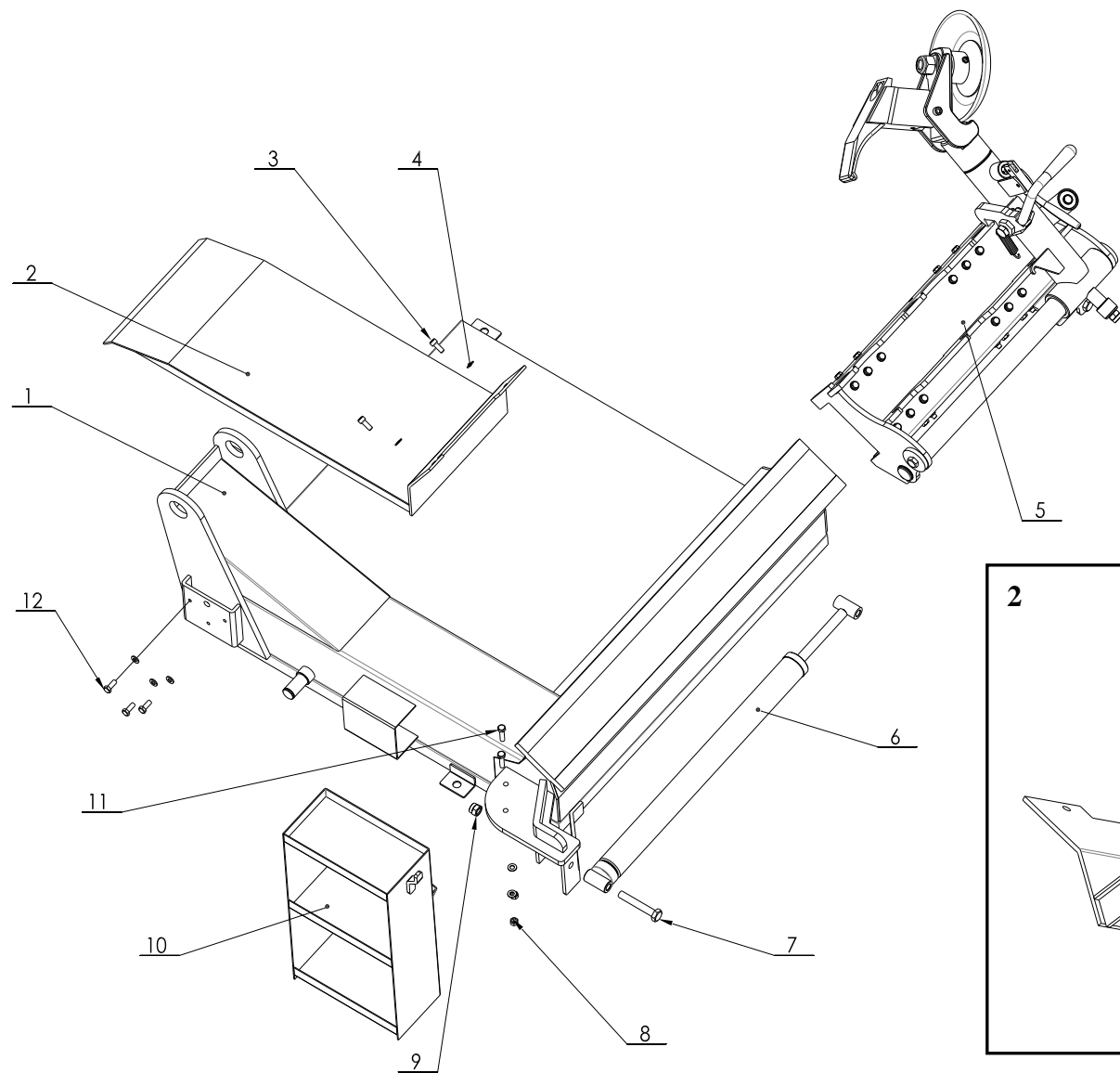

TAV.1.0	FRAME	ED. 10/11
---------	-------	-----------

ITEM	PART NO.	DESCRIPTION	QTY	REMARK
1	CC-101000	Base	1	
2	CC-702000	Ramp	1	
3	0202061	Screw M10X25 - GB/T70.1	2	
4	0205011	Washer D.10 - GB/T97.1	7	
5	CC-200000	Carriage and tools	1	
6	C-2C120-50-0G	Carriage cylinder	1	
7	0201101	Screw M16X100 - GB/T5782	1	
8	0203009	Nut M10 - GB/T6170	2	
9	0204008	Nut M16 - GB/T889.1	1	
10	CC-900100	Accessory box	1	
11	0201050	Screw M10X40 - GB/T5782	2	
12	0201062	Screw M10X25 - GB/T5783	3	
13	C-2C120-50-100	Cylinder liner	1	
14	0212001	Seeger D.16 - GB/T 894.1	1	
15	0312010	Gasket 50X34	1	
16	C-2C120-50-2	Piston	1	
17	0309019	O-ring 18X2.4 - GB1235	1	
18	C-2C120-50-5G	Cylinder shaft	1	
19	0309030	O-ring 50X3.1 - GB1235	1	
20	0305006	Guide ring D.25X25X2.5 - GB/T15242.2	1	
21	C-2C120-50-4G	Cylinder guide cover	1	
22	0310008	Sealing ring 25X33X5	1	
23	0311001	Scraper D.25	1	
24	CC-700100	Ramp	1	
25	0202051	Screw M8X80 - GB/T70.1	3	
26	CC-701001	Nylon wheel	3	
27	0204004	Nut M8 - GB/T889.1	3	

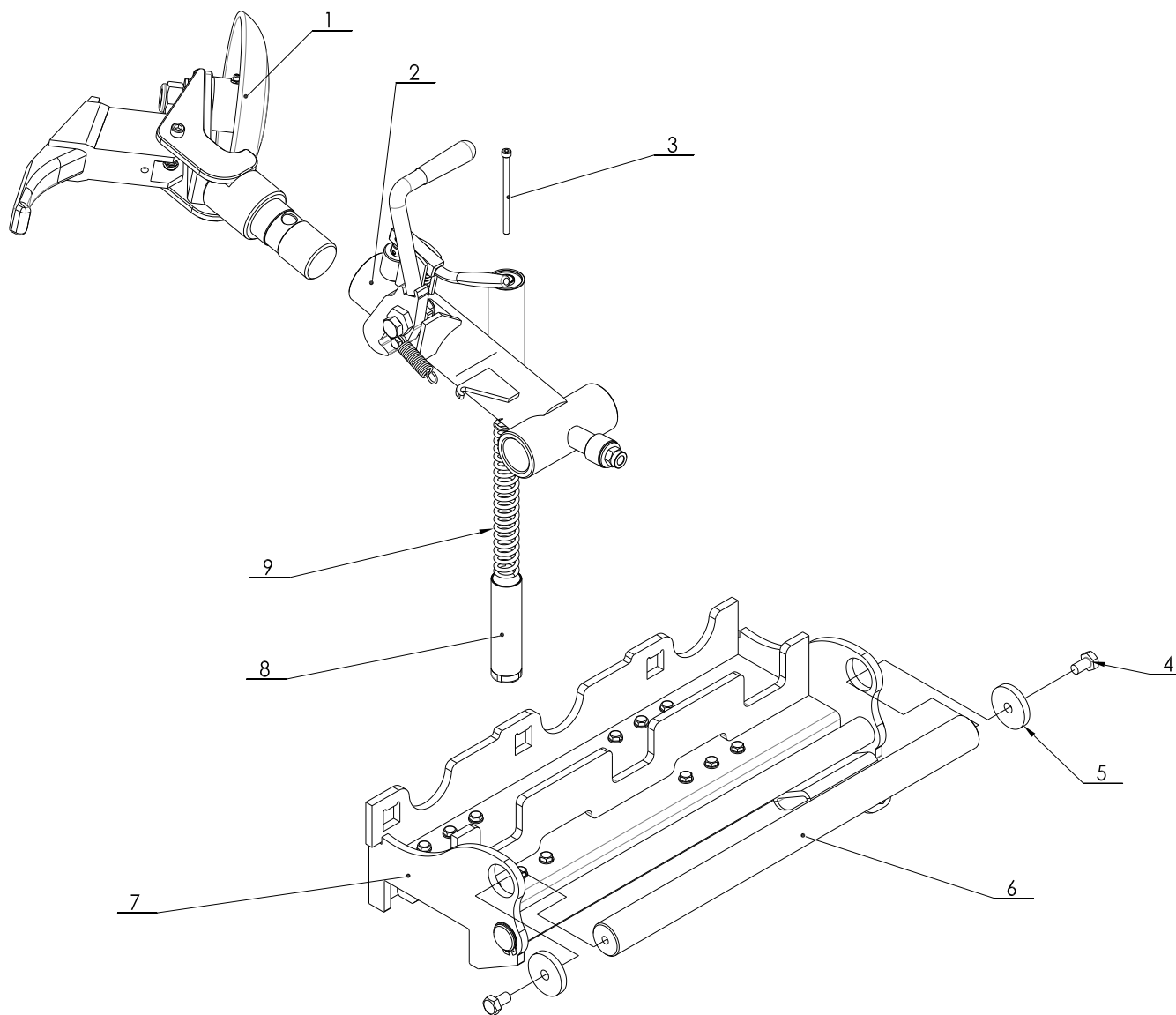

TAV.1.5	CARRIAGE AND TOOLS	ED. 10/11
---------	--------------------	-----------

ITEM	PART NO.	DESCRIPTION	QTY	REMARK
1	CC-620000	Double tool	1	
2	CC-610000Y	Tool arm	1	
3	0202039	Screw M8X130 - GB/T70.1	1	
4	0201093	Screw M14X25 - GB/T5781	2	
5	CC-201009	Washer	2	
6	CC-201008	shaft	1	
7	CC-201000	Carriage	1	
8	YC8-2400984	Expeller	1	
9	YC8-3001038	Spring	1	



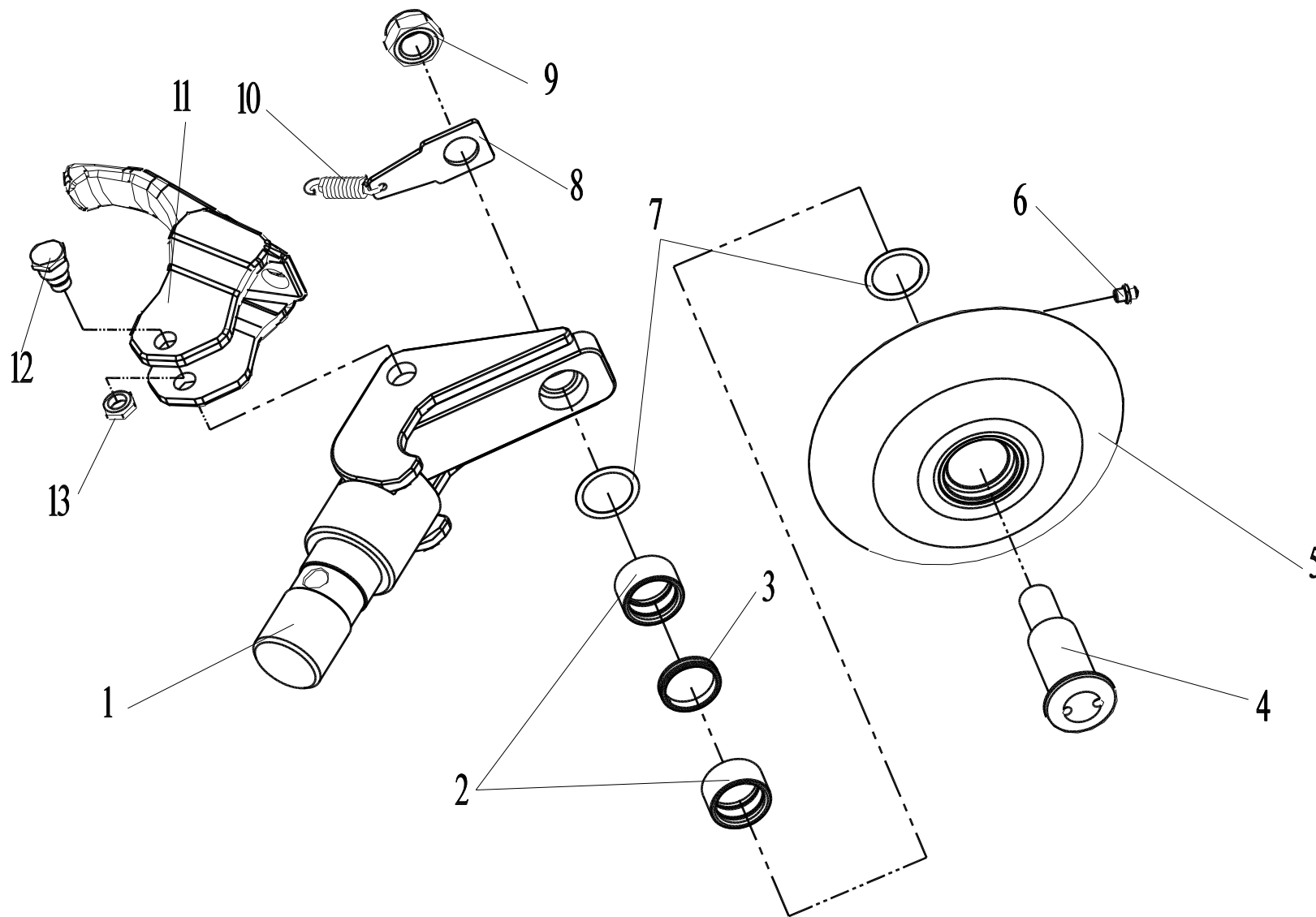

TAV.1.5.1

## DOUBLE TOOL

ED. 10/11

ITEM	PART NO.	DESCRIPTION	QTY	REMARK
1	CC-620200	Tool support	1	
2	CC-620002	Bead breaking disk bush	2	
3	CC-620003	Spacer	1	
4	CC-620001	Pin	1	
5	CC-620100	Bead breaking disk	1	
6	0215020	Greaser 10X1	1	
7	YC8-4396915	Steel shim	2	
8	CC-620004	Spring connection	1	
9	0204011	Nut M27 - GB/T889.1	1	
10	CC-620005	Spring	1	
11	CC-620300A	Short tool	1	
12	CC-620007	Pin	2	
13	0204014	M16X1.5- GB/T6173	2	

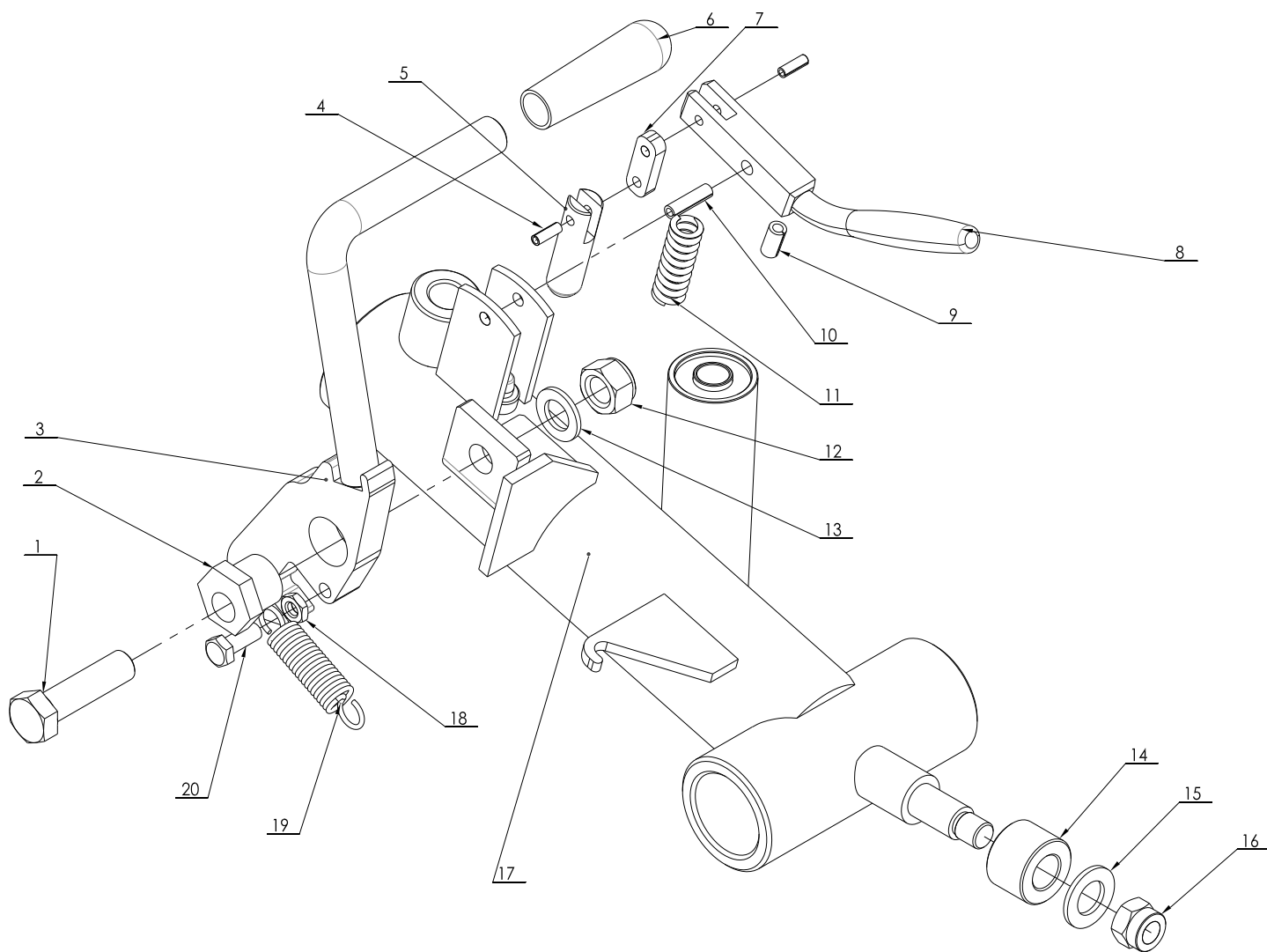

TAV.1.5.2

## TOOL ARM

ED. 10/11

ITEM	PART NO.	DESCRIPTION	QTY	REMARK
1	0201128	Screw M18X65 - GB/T5783	1	
2	CC-610001	Cam	1	
3	CC-610200	Hook	1	
4	0213005	Elastic pin 6X18- GB/T879.1	2	
5	YC8-3001029	Sliding bolt	1	
6	0511007	PVC handle	1	
7	YC8-3001028	Connection rod	1	
8	YC8-3001030b	Lever	1	
9	0213001	Elastic pin 10X20 - GB/T879.1	1	
10	0213007	Elastic pin 8X30 - GB/T879.1	1	
11	YC8-3001040	Spring	1	
12	0204009	Nut M18 - GB/T889.1	1	
13	0205021	Washer D.18 - GB/T97.1	1	
14	CC-610003	Roller	1	
15	0205022	Washer D.20 - GB/T97.1	1	
16	0204008	Nut M16 - GB/T889.1	1	
17	CC-610100Y	Tool arm	1	
18	0204012	Nut M10 - GB/T6172.1	1	
19	CC-610002	Bead breaking arm spring	1	
20	0201064	Screw M10X25 - GB/T5783	1	

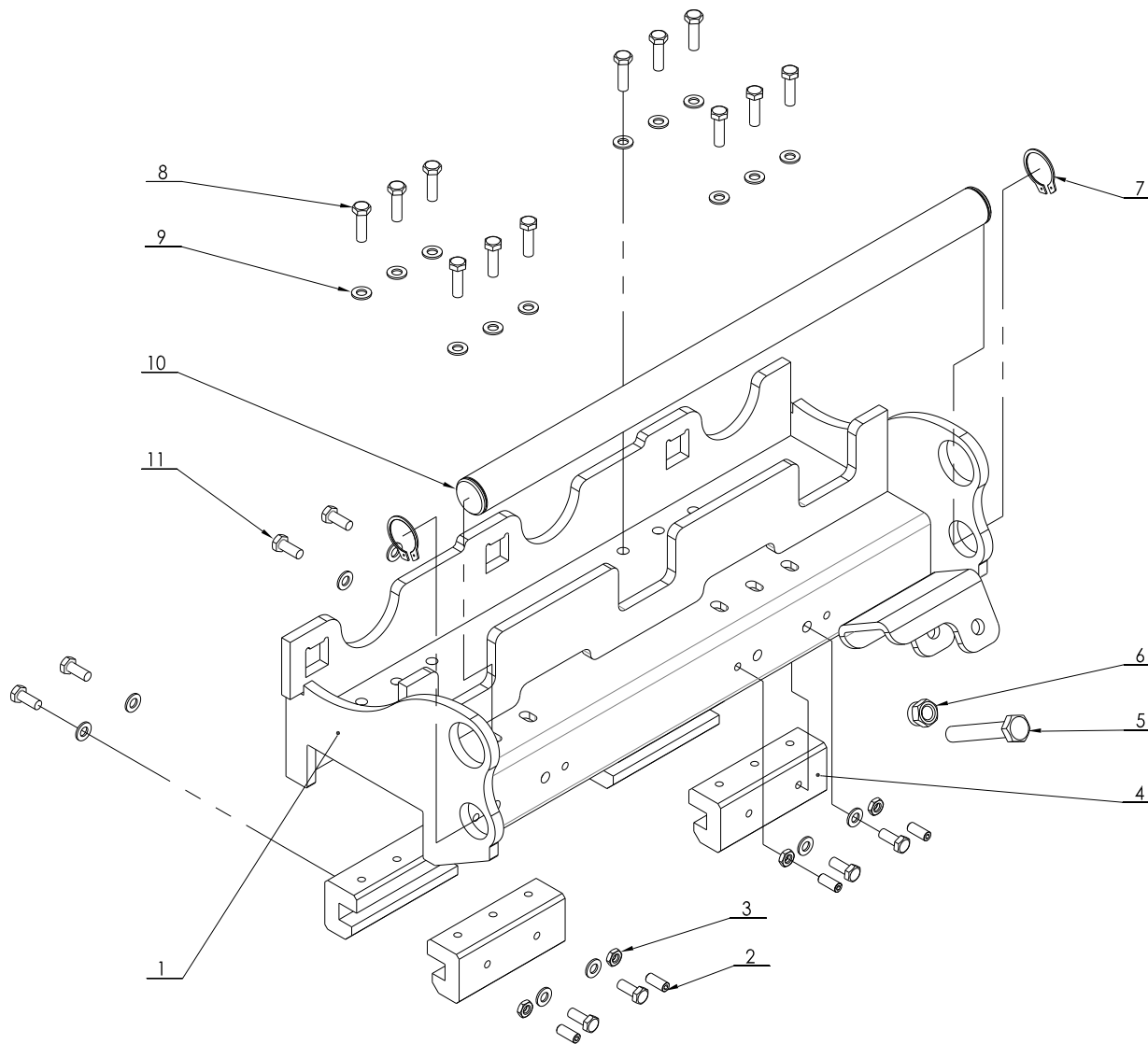

TAV.1.5.7	CARRIAGE	ED. 10/11
-----------	----------	-----------

ITEM	PART NO.	DESCRIPTION	QTY	REMARK
1	CC-200100	Carriage	1	
2	0209036	Screw M10X25 - GB/T77	4	
3	0204012	Nut M10 - GB/T6172.1	4	
4	CC-201010	Carriage slide	4	
5	0201101	Screw M16X100 - GB/T5782	1	
6	0204008	Nut M16 - GB/T889.1	1	
7	0212008	Seeger D.40 - GB/T894.1	2	
8	0201050	Screw M10X35 - GB/T5783	12	
9	0205011	Washer D.10 - GB/T97.1	20	
10	CC-201007	Tool arm shaft	1	
11	0201064	Screw M10X25 - GB/T5783	8	

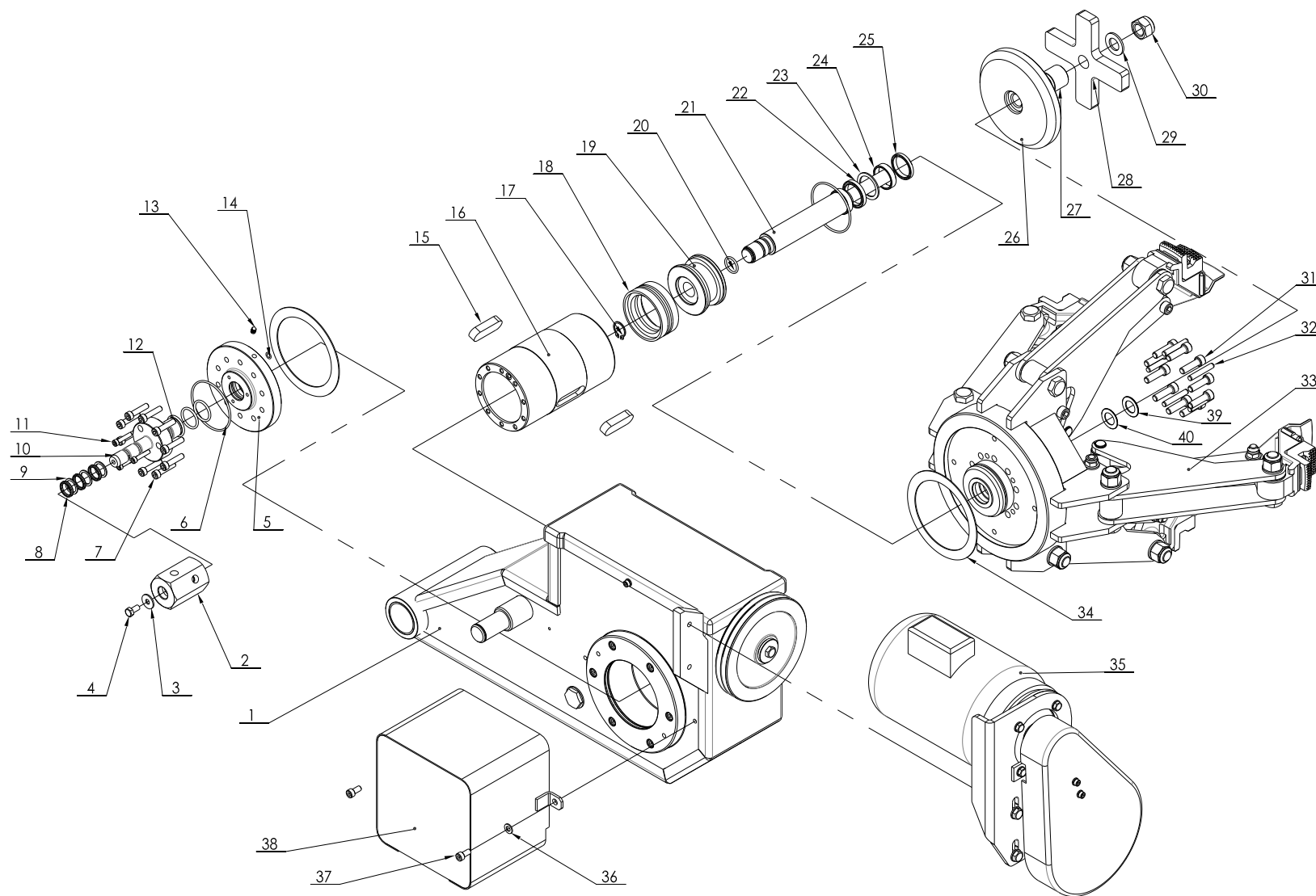

ITEM	PART NO.	DESCRIPTION	QTY	REMARK
1	CC-310000A	Gear Box	1	
2	C-2C120-85-6	Pivot union body	1	
3	0205009	Washer D.8 - GB/T96	1	
4	0201026	Screw M8X16 - GB/T5783	1	
5	C-2C120-85-4	Cylinder back cover	1	
6	0309076	O-ring 85x3.1	2	
7	0202042	Screw M8X35 - GB/T70.1	10	
8	0313014	Sealing ring 20X3.53	3	
9	C-2C120-85-7	Ring	3	
10	C-2C120-85-5	Pin	1	
11	0202026	Screw M6X30 - GB/T70.1	3	
12	0309026	O-ring 36X3.5	3	
13	0305001	Plug QD07	2	
14	0309007	O-ring 11X1.9	1	
15	0213029	Tab 20X60 - GB/T1096	2	
16	C-2C120-85-1	Cylinder liner	1	
17	0212003	Seeger D.24 - GB/T894.1	1	
18	0312017	Gasket 85X65	1	
19	C-2C120-85-3	Piston	1	
20	0309023	O-ring 28X3.1	1	
21	C-2C120-85-2	Cylinder shaft	1	
22	0310010	Sealing ring 35X45X6	1	
23	C-2C120-85-9	Ring 35X45X2	1	
24	0305007	Guide ring 35x10x2.5	2	
25	0311006	Scraper 35X43	1	
26	CC-580101	Chuck opening control plate	1	
27	CC-580103	Spacer	1	



TAV.2.0	SELF-CENTERING CHUCK	ED. 10/11
---------	----------------------	-----------

28	CC-580102	Cross piece	1
29	0205022	Washer D.20 - GB/T97.1	1
30	0204029	Nut M20X1.5 - GB/T889.2	1
31	0202079	Screw M10X35 - GB/T70.1/	10
32	0213067	Elastic pin 8X50 - GB/T119.1	5
33	CC-510200	Chuck	1
34	CC-810104	Self-lubricated washer	2
35	CC-400200	Motor unit	1
36	0205008	Washer D.8 - GB/T97.1	2
37	0202040	Screw M8X16 - GB/T70.1	2
38	CC-820100	Pivot union cover	1
39	CC-580104	Steel shim A	1
40	CC-580105	Steel shim B	1

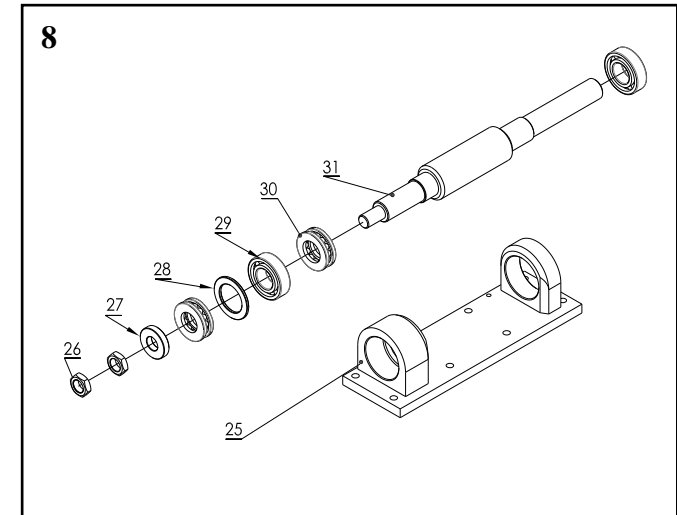
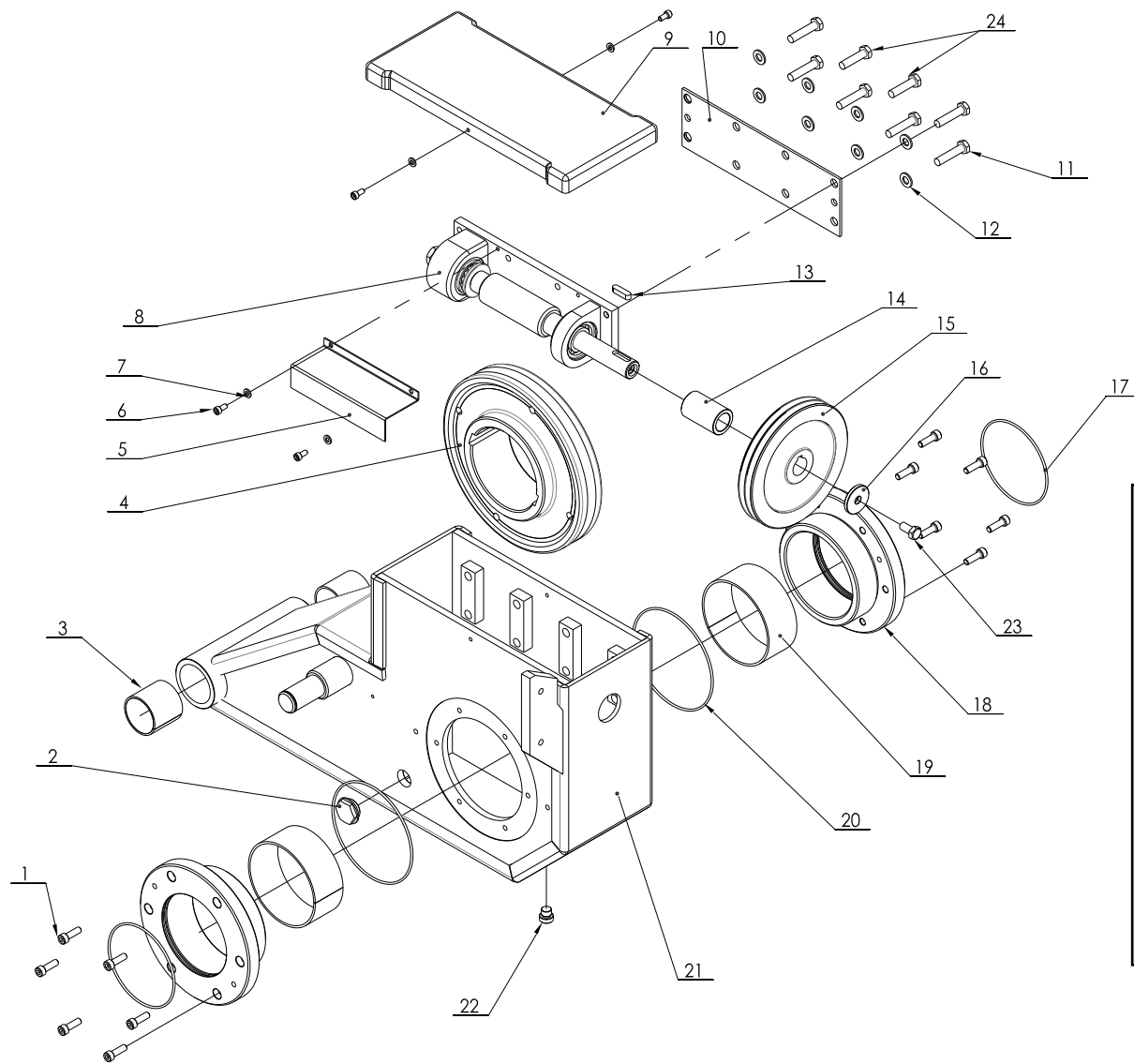

TAV.2.1	GEAR BOX	ED. 10/11
---------	----------	-----------

ITEM	PART NO.	DESCRIPTION	QTY	REMARK
1	0202047	Screw M8X25 - GB/T70.1	12	
2	0215024	Oil indicator A M27X1.5	1	
3	0210035	Self-lubricated bush 5050	2	
4	CC-410101A	Helical gear	1	
5	YC8-3001010	Oil screen	1	
6	0202024	Screw M6X12 - GB/T70.1	4	
7	0205006	Washer D.6 - GB/T97.1	4	
8	CC-400100	Worm unit	1	
9	CC-840201A	Cover	1	
10	CC-810102	Support plate	1	
11	0201051	Screw M10X45- GB/T5782	6	
12	0205011	Washer D.10 - GB/T97.1	8	
13	0213025	Tab 8X30 - GB/T1096	1	
14	CC-410103	Bush	1	
15	YC8-3001052b	Driven pulley	1	
16	CC-410106	Washer	1	
17	0309012	O-ring 120X3.1	2	
18	CC-810101	Flange	2	
19	0210037	Self-lubricated bush 11550	2	
20	0309047	O-ring 145X3.1	2	
21	CC-311300	Gear box	1	
22	0305016	Plug G1/4	1	
23	0201065	Screw M10X20- GB/T5783	1	
24	0201068	Screw M10X40 - GB/T5782	2	
25	YC8-3001009	Worm support	1	
26	0204014	Nut M16X1.5 - GB/T6173	2	
27	CC-410105	Washer	1	

TAV.2.1	GEAR BOX		ED. 10/11
---------	----------	--	-----------

28	CC-410104	Washer	1
29	0214019	Bearing 6205 - GB/T276	2
30	0214009	Bearing 51205 - GB/T301	2
31	CC-410102	Worm screw	1

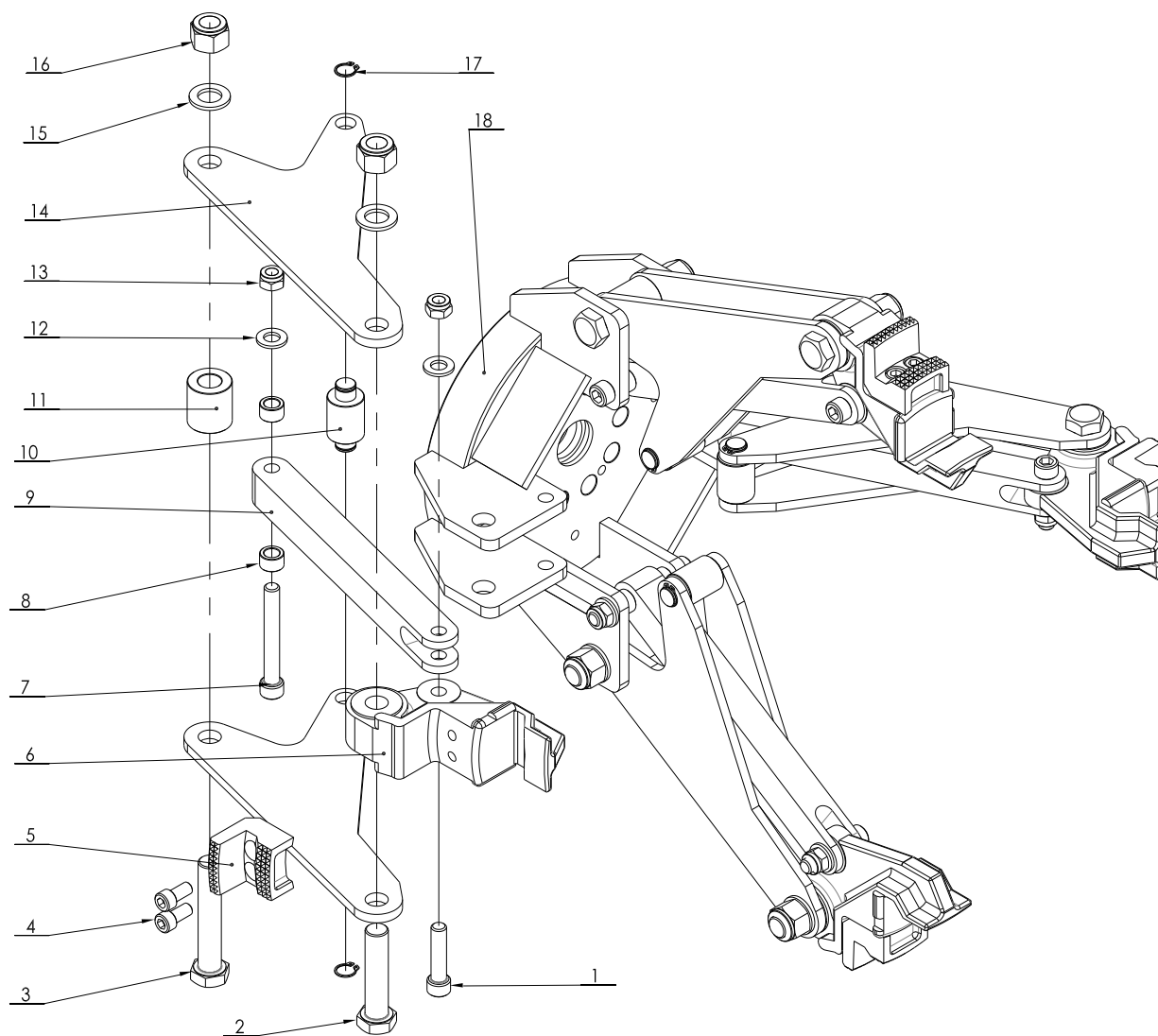

ITEM	PART NO.	DESCRIPTION	QTY	REMARK
1	0202072	Screw M12X50 - GB/T70.1	4	
2	0201118	Screw M18X1.5X80 - GB/T5785	4	
3	0201105	Screw M18X1.5X100- GB/T5785	4	
4	0202060	Screw M10X20- GB/T70.1	8	
5	CC-510101	Clamp	4	
6	CC-510102	Clamp support	4	
7	0202095	Screw M12X90 - GB/T70.1	4	
8	CC-510205	Spacer	8	
9	CC-510202	Chuck lever	4	
10	CC-510203	Pin	4	
11	CC-510204	Spacer	4	
12	0205013	Washer D.12 - GB/T97.1	8	
13	0204007	Nut M12 - GB/T889.1	8	
14	CC-510201	Chuck arm	8	
15	0205021	Washer D.18 - GB/T97.1	8	
16	0204010	Nut M18X1.5 - GB/T889.2	8	
17	0212002	Seeger D.16 - GB/T894.1	8	
18	CC-520100	Turntable	1	

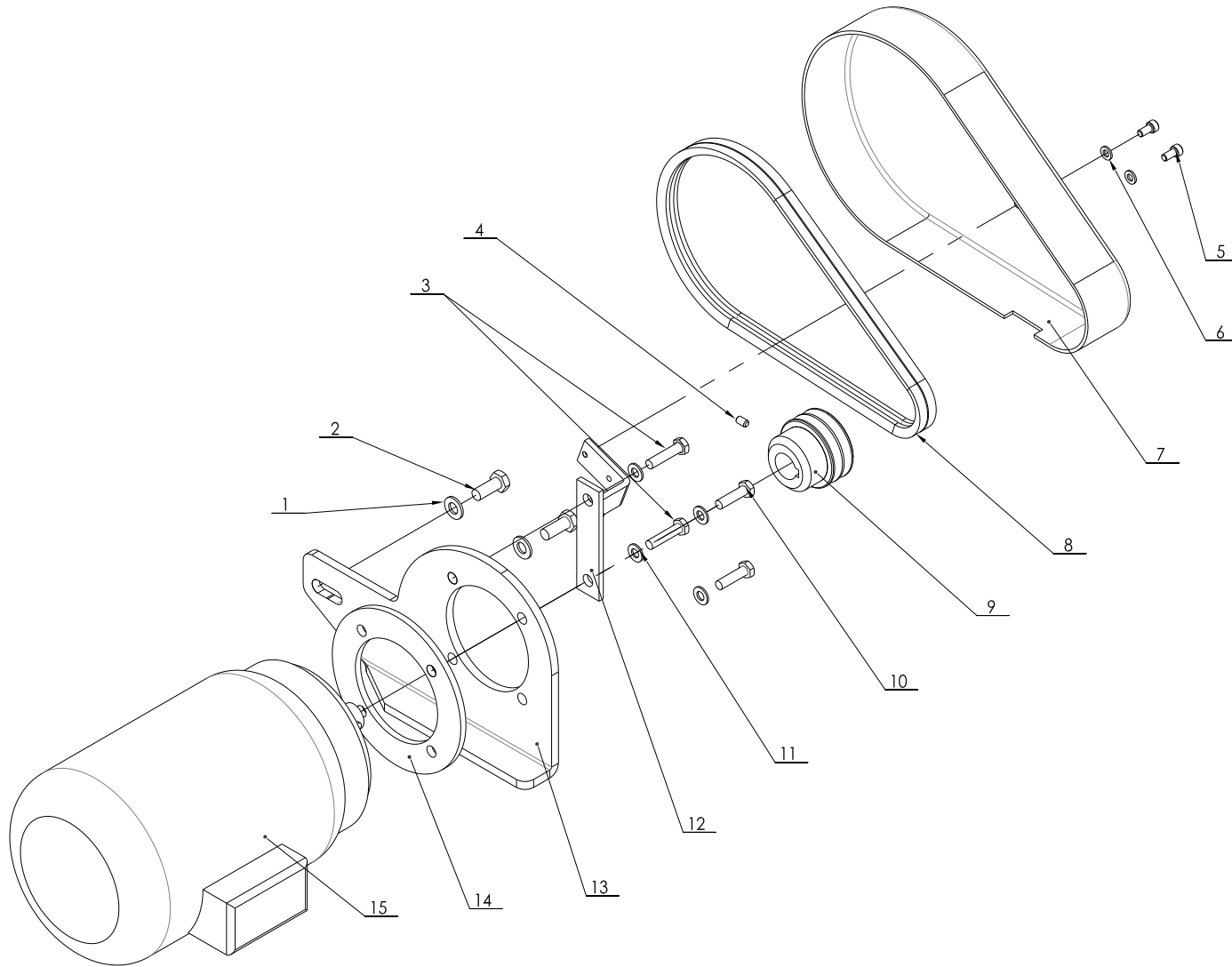

TAV.2.35	MOTOR UNIT	ED.10/11
----------	------------	----------

ITEM	PART NO.	DESCRIPTION	QTY	REMARK
1	0205011	Washer D.10 - GB/T97.1	2	
2	0201064	Screw M10X25 - GB/T5783	2	
3	0201117	Screw M8X35 - GB/T5782	2	
4	0209037	Screw M6X10 - GB/T80	1	
5	0202024	Screw M6X12 - GB/T70.1	2	
6	0205006	Washer D.6 - GB/T97.1	2	
7	CC-840100A	Belt casing	1	
8	0511077	Driven belt V 800	2	
9	CC-480101V	Belt pulley	1	
10	0201031	Screw M8X30 - GB/T5783	2	
11	0205008	Washer D.8 - GB/T97.1	4	
12	CC-830200	Belt casing support	1	
13	CC-830101	Motor support	1	
14	CC-830102V	Spacer	1	
15a	0509064	Double speed motor 1.3KW/1.8KW 380V/50HZ/3PH	1	
15b	0509045	Double speed motor 1.3KW/1.8KW 400V/50HZ/3PH	1	
15c	0509029	Double speed motor 1.3KW/1.8KW 220V/60HZ/3PH	1	
15d	0509037	Motor 1.5KW 220V/50HZ/1PH	1	
15e	0509042	Motor 1.5KW 220V/60HZ/1PH	1	



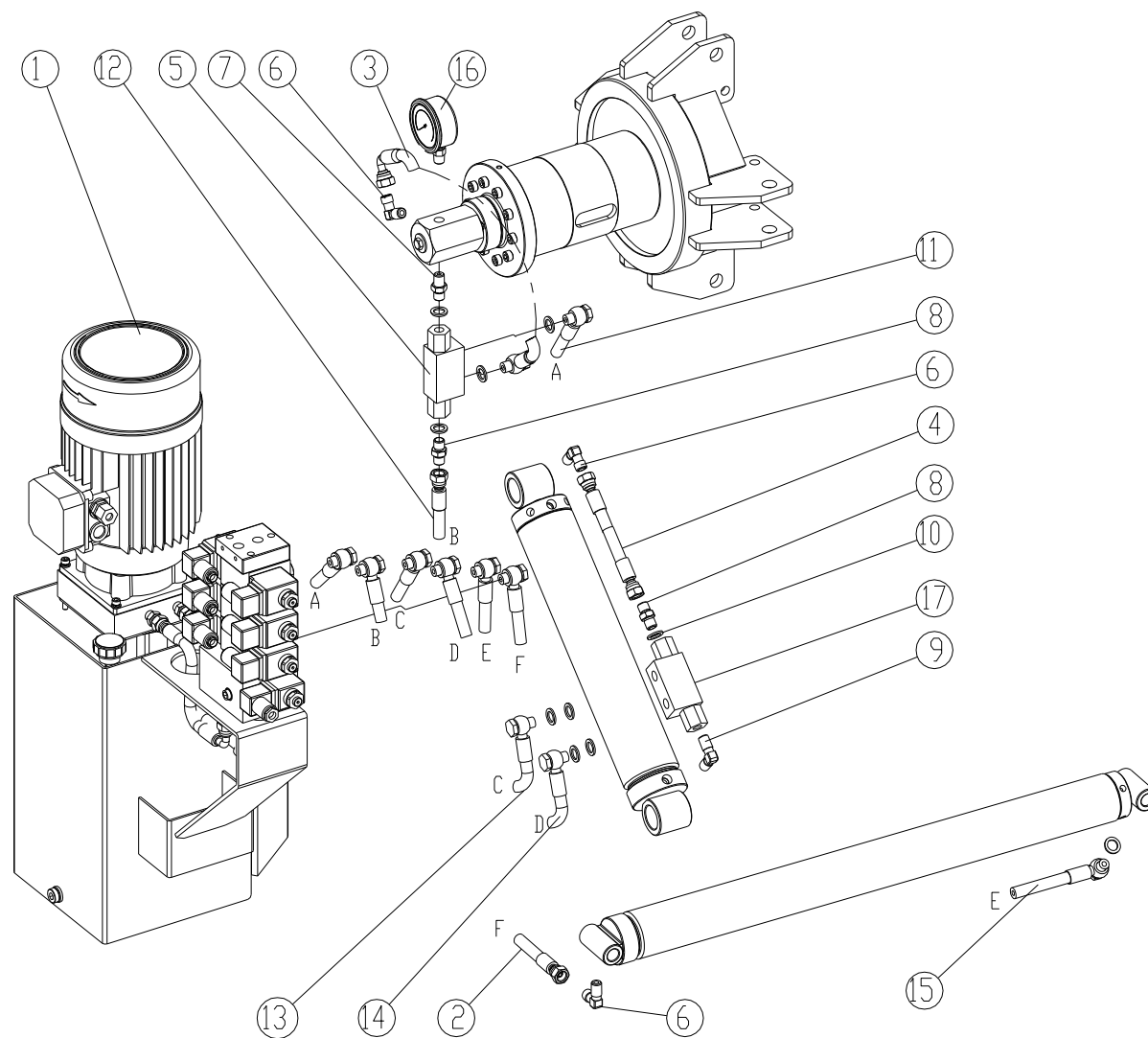

TAV.6.0	HYDRAULIC UNIT	ED. 10/11
---------	----------------	-----------

ITEM	PART NO.	DESCRIPTION	QTY	REMARK
1	302-BZ-0	Power unit	1	
2	302-ZJ1390	Hydraulic hose L=1390	1	
3	302-WJ310	Hydraulic hose L=310	1	
4	302-ZZ200	Hydraulic hose L=200	1	
5	0307020	Stop valve BP17000000	1	
6	0303003	90° union 1/4	3	
7	0302005	Union 1/4	1	
8	0302007	Union 1/4	2	
9	0304011	90° union 1/4"	1	
10	0313001	Washer 1/4	27	
11	302-JJ840	Hydraulic hose L=840	1	
12	302-ZJ700	Hydraulic hose L=700	1	
13	302-JJ805	Hydraulic hose L=805	1	
14	302-JJ840	Hydraulic hose L=840	1	
15	302-JJ1900	Hydraulic hose L=1900	1	
16	0307052	Pressure gauge 250bar	1	
17	0307042	Stop valve BP25000000	1	

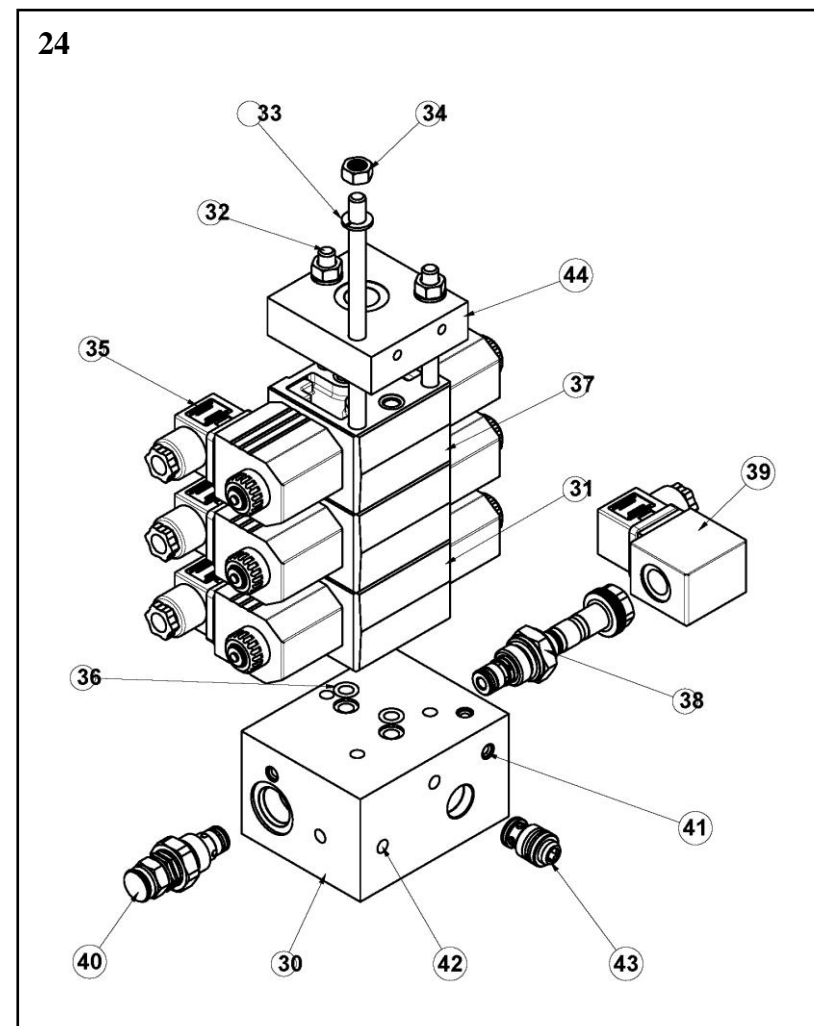
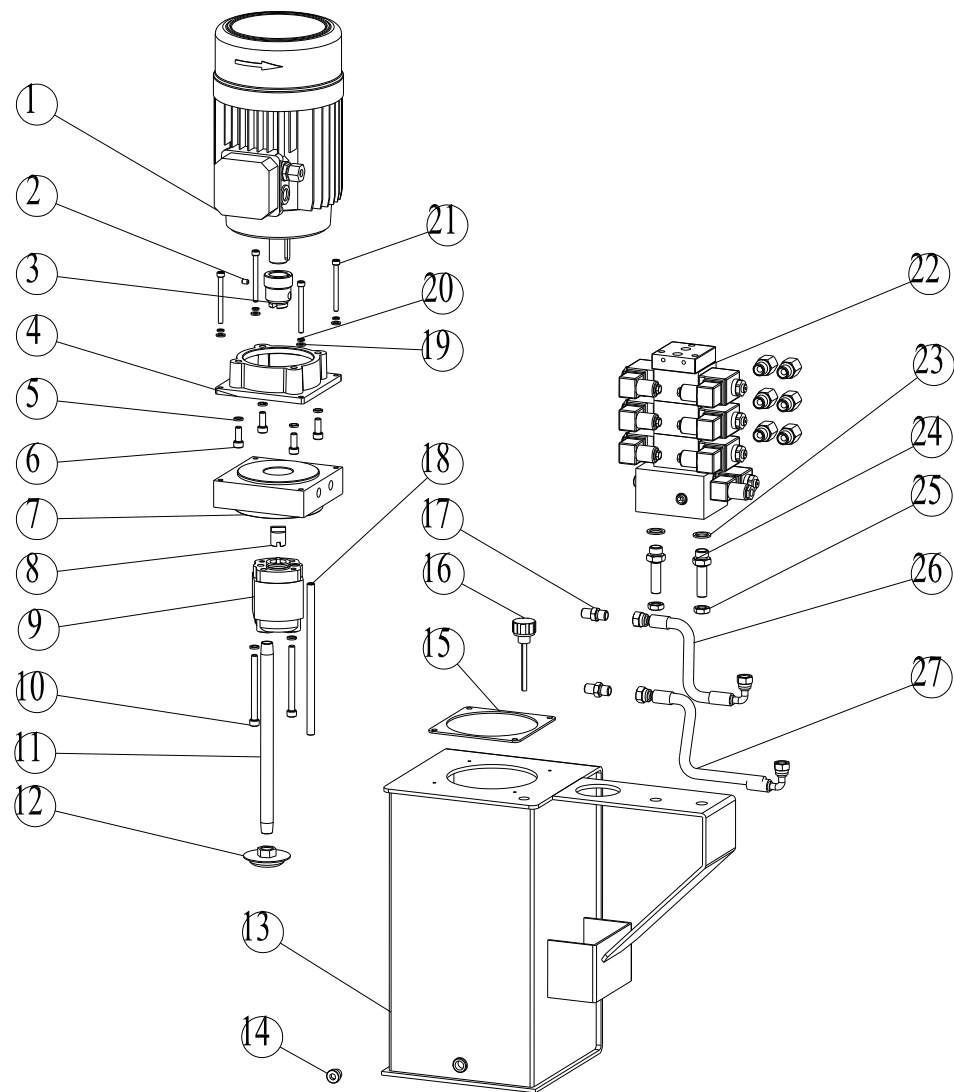

TAV.6.1	POWER UNIT	ED. 10/11
---------	------------	-----------

ITEM	PART NO.	DESCRIPTION	QTY	REMARK
1a	0509026	Motor 1.5KW 380V/50HZ/3PH	1	
1b	0509076	Motor 1.5KW 400V/50HZ/3PH	1	
1c	0509044	Motor 1.5KW 220V/60HZ/3PH	1	
1d	0509037	Motor 1.5KW 220V/50HZ/1PH	1	
1e	0509042	Motor 1.5KW 220V/60HZ/1PH	1	
2	0209042	Screw M6X8 - GB/T80	1	
3	BZ-ZT24	Motor joint	1	
4	BZ-DJ-1B	Motor flange	1	
5	0208006	Washer D.8 - GB/T93	6	
6	0202045	Screw M8X20 - GB/T70.1	4	
7	BZ-ZB-O	Manifold	1	
8	BZ-BJ25	Pump joint	1	
9	0301014	Gear pump 3.3CC	1	
10	0202053	Screw M8X90 - GB/T70.1	2	
11	BZ-G18X265	Oil draining pipe	1	
12	0305010	Oil filter 3/8	1	
13	2C120-BZ-1	Oil tank	1	
14	0305016	Plug 1/4	1	
15	BZ-F-01	Gasket	1	
16	0305026	Oil level plug 3/8	1	
17	0302005	Union 1/4	2	
18	BZ-G10X210	Oil returning pipe	1	
19	0205006	Washer D.6 - GB/T97.1	4	
20	0208005	Washer D.6 - GB/T93	4	
21	0202036	Screw M6X65 - GB/T70.1	4	
22	0307046	Multiple base with solenoid valves PR09007B	1	
23	0313012	Washer 3/8	2	

TAV.6.1	POWER UNIT	ED. 10/11
---------	------------	-----------

24	2C120-A2	Union	2
25	8B-04	Special nut	2
26	302-ZW240	Hydraulic hose L=240	1
27	302-ZW280	Hydraulic hose L=280	1
30	0307108	Interface block PR09007C	1
31	0307096	ED06Z Modular directional valve 24Vdc C161401002	2
32	K211524000	Stud M8x190	3
33	C012506000	Washer D.8 DIN128A	3
34	C010506000	Nut M8 UNI 5588	3
35	C160001000	Standard connector black	6
36	C000110000	Seal OR 108 (8.73X1.78) NBR70	2
37	0307097	ED08Z Modular directional valve 24Vdc C161403002	1
38	0307098	2/2 Electric valve normally open VE3-NA V389674A20	1
39	C166455OC2	S-CE+C coil 24Vcc 18W with connector	1
40	V388904A23	VM15 Relief valve 80-250bar	1
41	C011707000	Ball sealing plug MB800-080	5
42	C011804000	Sealing plug D.7	3
43	V389209000	VU3/8" Check valve	1
44	0307108	Closing plate with P port 3/8"BSPP R933003329	1

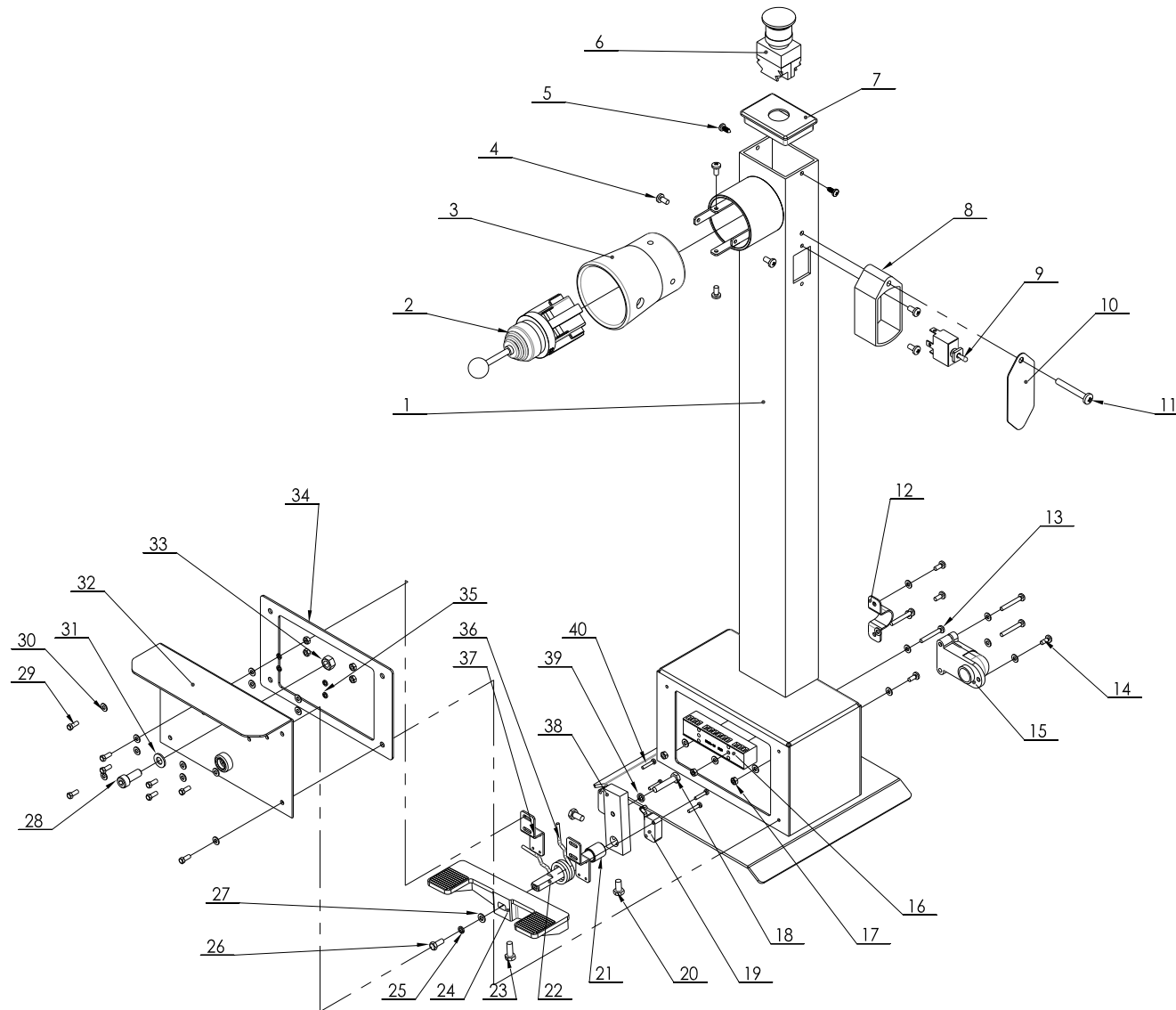

ITEM	PART NO.	DESCRIPTION	QTY	REMARK
1	YC8-2406762	Pedal unit base	1	
2	0505010	Manipulator	1	
3	0606020	Rubber cover	1	
4	0206024	Screw M5X10 - GB/T818	6	
5	0207035	Screw ST4.2X12 - GB/T845	2	
6	0502044	Emergency switch LAY37-02	1	
7	J3A-200006	Cap A	1	
8	T-23-02B	Switch support	1	
9	0505016	Commutator	1	
10	T-23-03A	Switch cover	1	
11	0206039	Screw M6X45 - GB/T818	1	
12	YC8-3001069	U bolt	1	
13	0206018	Screw M4X30 - GB/T818	4	
14	0206012	Screw M4X10 - GB/T818	4	
15	YC8-3000901	Harness holder	1	
16	0507009	Terminal board	1	
17	0203002	Nut M4 - GB/T6170	7	
18	0201019	Screw M6X30 - GB/T5780	1	
19	0505014	Micro switch	2	
20	0201010	Screw M6X12 - GB/T5781	2	
21	YC8-3001135	Spacer	1	
22	YC8-3015413	Spring support	1	
23	0201012	Screw M6X16 - GB/T5781	1	
24	YC8-3015412	Pedal	1	
25	0208003	Washer D.5 - GB/T93	1	
26	0201006	Screw M5X12 - GB/T5781	1	
27	0205004	Washer D.5 - GB/T97.1	1	

TAV.7.0	PADEL CONTROL	ED. 10/11
---------	---------------	-----------

28	0202045	Screw M8X20 - GB/T70.1	1
29	0201001	Screw M4X10 - GB/T5781	8
30	0205002	Washer D.4 - GB/T97.1	23
31	0205008	Washer D.8 - GB/T97.1	1
32	YC8-2400977	Pedal box	1
33	0203008	Nut M8 - GB/T6170	1
34	YC8-3001138	Gasket	1
35	0208002	Washer D.4 - GB/T93	4
36	YC8-3007133b	Pedal control spring	1
37	YC8-3001143a	Switch support	2
38	YC8-3001131	Lever	1
39	0208005	Washer D.6 - GB/T93	1
40	0206002	Screw M3X16 - GB/T818	4



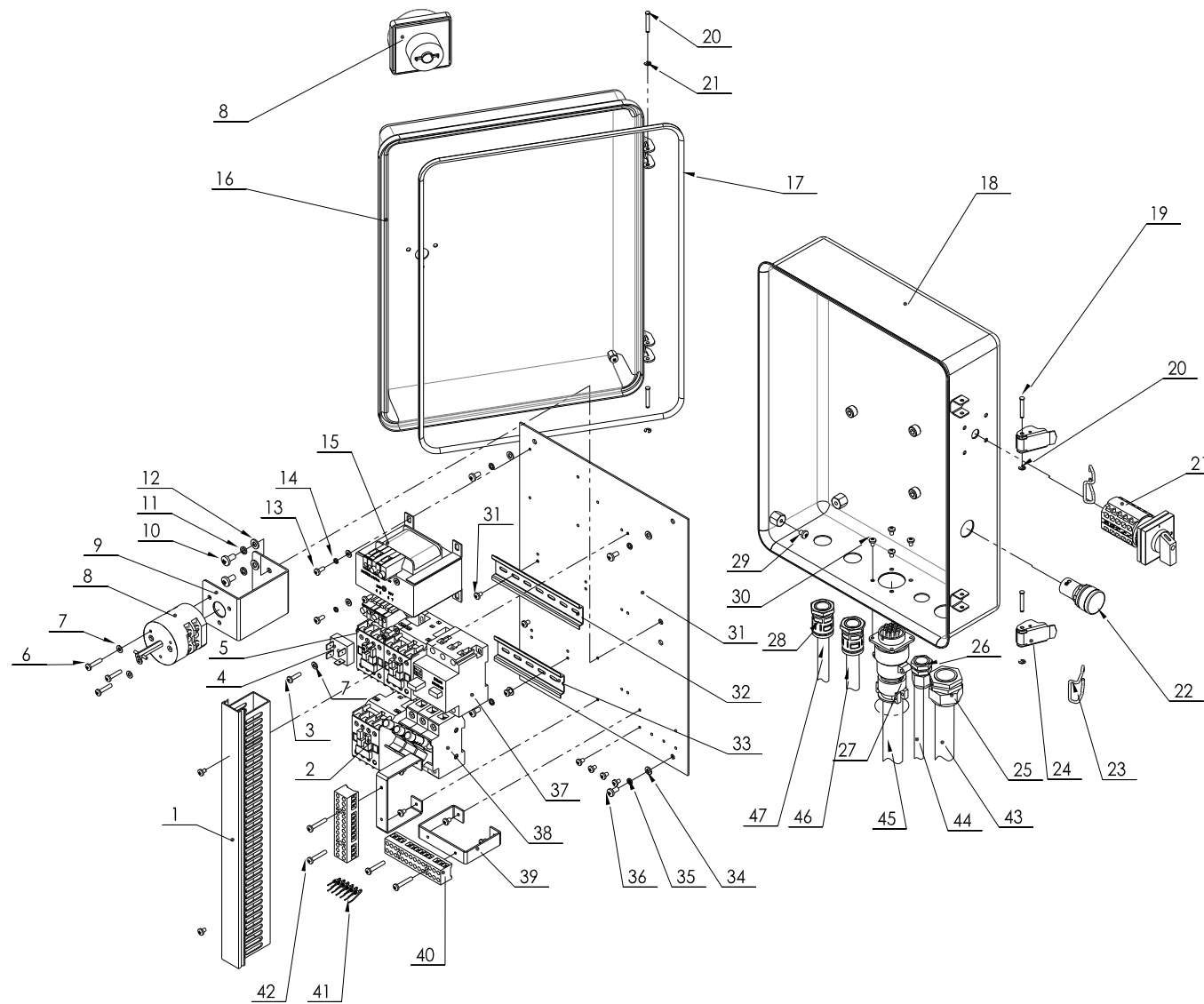

ITEM	PART NO.	DESCRIPTION	QTY	REMARK
1	0511078	Wiring terminal 25X50X370	1	
2	0501002	Contactor 1201 AC24V	1	
3	0206015	Screw M4X16	1	
4	0508006	Rectifier 3510	1	
5	0501004	Contactor 1801 AC24V	2	
6	0206016	Screw M4X20	3	
7	0205002	Washer D.4	8	
8	0505025	Power switch 20A	1	
9	CC-850222	Switch support	1	
10	0206040	Screw M6X12	2	
11	0208005	Locking washer D.6	2	
12	0205006	Washer D.6	2	
13	0206012	Screw M4X10	4	
14	0208002	Locking washer D.4	4	
15	0503067	Transformer 115VA 230V/400V	1	
16	S551-02	Front cover	1	
17	0511026	Gasket	1	
18	S551-01D	Back cover	1	
19	S551-6	Pin	4	
20	0211018	Seeger D.3	4	
21	0505013	Pole change switch 20A	1	
22	0502023	Pilot lamp AC24V	1	
23	S551-4	Hook	2	
24	S551-5	Clamp	2	
25	0508012	Cable relief M27	1	
26	0508253	Cable relief M20	1	
27	0508280	Cable connector P32-14	1	

28	0507118	Conduit connector M20-D18.5	2
29	0206014	Screw M5X6	2
30	0206019	Screw M4X6	18
31	3054510400	Support	1
32	0508330	Guide 35X145	1
33	0508330	Guide 35X110	1
34	0205004	Washer D.5	4
35	0208003	Locking washer D.5	4
36	0206024	Screw M5X10	4
37	0501020	Circuit breaker 6.3-10A	1
38a	0504009	Overload cutoff 16A 10X38 for 380V/400V	3
38b	0504013	Overload cutoff 32A 10X38 for 220V/230V	2
39	CC-850223	Support	2
40	0507009	Terminal board H3081-12	2
41	0507027	LED IN5408	6
42	0206017	Screw M4X25	4
43	C53AD13050	Electric cable for the valves	1
44	0506016	Electric cable for the power supply	1
45	C53AD13030	Electric cable for the pedal control	1
46	0506016	Electric cable for power unit motor	1
47	C53AD13010	Electric cable for the chuck motor	1

# ACCESSORIES

ED. 10/11

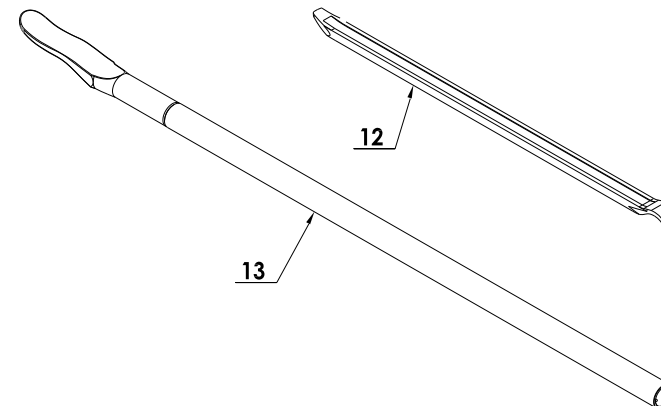
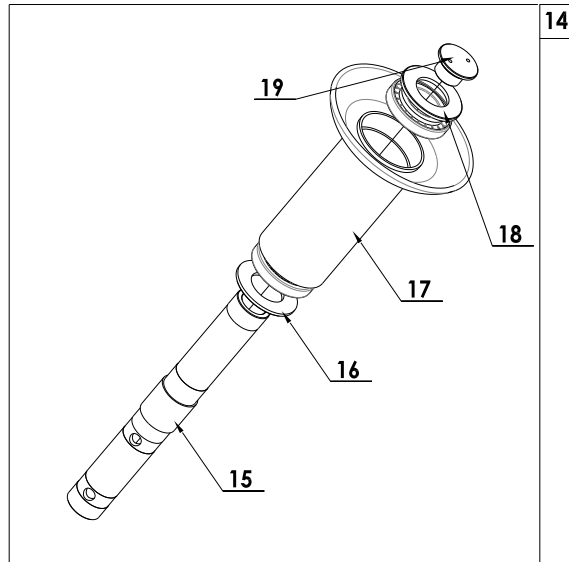
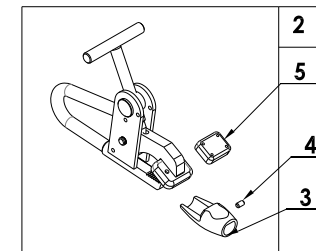
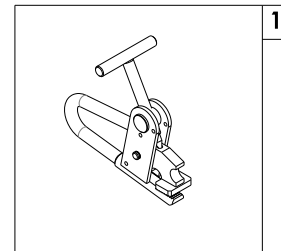
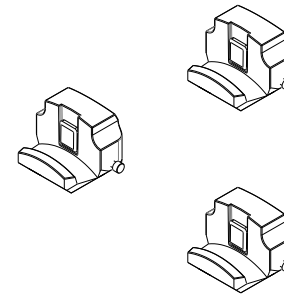
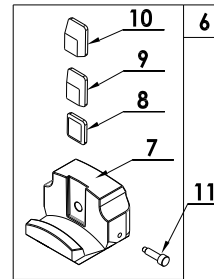
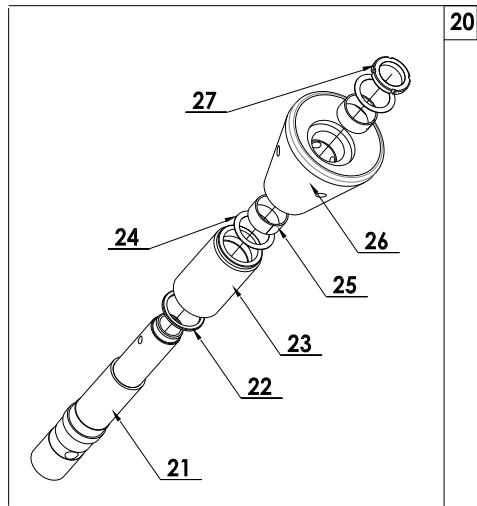

**ACCESSORIES**

**ED. 10/11**

<b>ITEM</b>	<b>PART NO.</b>	<b>DESCRIPTION</b>	<b>QTY</b>	<b>REMARK</b>
1	DB-11	Pliers	1	
2	YC8-F200000	Pliers for alloy rim Art. 138/90	1	Optional
3	YC8-F202001	Alloy protection	1	
4	0209037	Screw M6X10 - GB/T80	1	
5	YC8-F201001	Block	1	
6	CC-F100100	Clamp protection kit Art. 137/90A	4	Optional
7	CC-F100101	Clamp protection	1	
8	YC8-F100102	Plastic insert 1	1	
9	YC8-F100103	Plastic insert 2	1	
10	YC8-F100104	Plastic insert 3	1	
11	YC8-F100105	Special screw	1	
12	0511040	Short tire lever 24"	1	
13	DB-12T	Long bead lifting lever	1	
14	C91A000000	Tubeless roller	1	Optional
15	C91A000001	Shaft	1	
16	C91A000002	Spacer	2	
17	C91A100000	Roller	1	
18	0214038	Bearing 30212	2	
19	C91A000003	Screw M45X1.5	1	
20	C91C000000A	Tubeless roller for aluminum rim	1	Optional
21	C91C000001	Shaft	1	
22	C61A400004	Spacer	1	
23	C61A400002	Round roller	1	
24	C61A400005	Spacer	2	
25	0210077	Self-lubricated bush 5050	2	
26	C61A400003	Conical roller	1	
27	0204046	Nut M45X1.5 - GB/T812	1	

