

# ***WHEEL ALIGNER***



## ***Parts Manual*** *Recommended Service Stock*

***V2100 / geo 630***  
***V2280 / geo 660***

*EEWA541G / EEWA721G*  
*EEWA544T / EEWA712T*

All information contained or disclosed in this document is considered confidential and proprietary by Snap-on. All manufacturing, use, reproduction, and sales rights are reserved by Snap-on and the information contained herein shall not be used in whole or in part without the express written consent of Snap-on.

# Table of Contents

V2100 / GEO 630 - BOM.....	2
V2280 / GEO 660- BOM.....	4
KIT, MOVEABLE BEAM (OPTION).....	4
KIT, TILT BEAM TOWER.....	6
KIT, MOVEABLE BEAM.....	8
CAMERA BEAM.....	10
SHELF ASSEMBLY 2100 / 630.....	12
CABINET ASSEMBLY 2280 / 660.....	13
ELECTRICAL BOX - V2100 / GEO 630.....	14
ELECTRICAL BOX - V2280 / GEO 660.....	16
ELECTRICAL BOX - V2280 / GEO 660.....	18
WHEEL CLAMP.....	20
TILT MECHANISM.....	22
WHEEL CLAMP (SEE BREAKDOWN PG20).....	24

## V2100 / GEO 630 - BOM

ITEM	REQ	PART NUMBER	DESCRIPTION
1	1	3-08006A	KIT, MOUSE/KEYBOARD, USB
2	1	EAK0289J61A	KIT - 22" LCD MONITOR
		2-85466A	CABLE, HDMI-HDMI, 6FT
3	1	EAA0469J67A	ASSY., SHELF, V2100 ELS
4	1	EAA0435V05B	BEAM ASM. - V2100 CAMERA
5	1		LABEL-CUSTOMER SVC, JBC
6	1	EAK0277J82A	LIT PACK - GENERIC
7	1	EAK0256J96A1	KIT - DECAL, ULTRA, JBC
* 8	1	EAL0452J65A	DECAL - V2100
9	1	EAK0350J22A	KIT, RIM CLAMP/TGT, V2100 ELS
* 14	1	88931	POWER CORD/LABEL ASM., 115V
* 15	1	55502	CLAMP ASM - WHEEL, STEERING
17	1		INSTALLATION REGISTRY, CERTIFICATE
* 19	1	96	DEPRESSOR ASM - BRAKE
* 20	2	EAC0090J82A	WHEEL CHOCK, RUBBER
21	1		LABEL-ELECTRICAL/ SERIAL
24	1	TEEWA541G	INSTALLATIONS INSTRUCTIONS
25	1	ZEEWA541G	MANUAL, QUICK START
26	1	EAK0268J05C	PRINTER KIT-TOP FEED
27	1	EAW0291V01A	CABLE, ETHERNET, CAT6A, 1.6M
28	1	EAE0049J84C	POWER SUPPLY, 19VDC, ISOLATED
29	1	EAS2105J99A	BRACKET, LCD MTG, 17-22"
* 30	8	1-2509	SCREW, BHC, 1/4-20 X 5/8
* 31	8	1-1646	WASHER, LOCK, 1/4-20
32	8	1-20141A	WASHER, FLAT, 1/4-20
* NOT SHOWN			

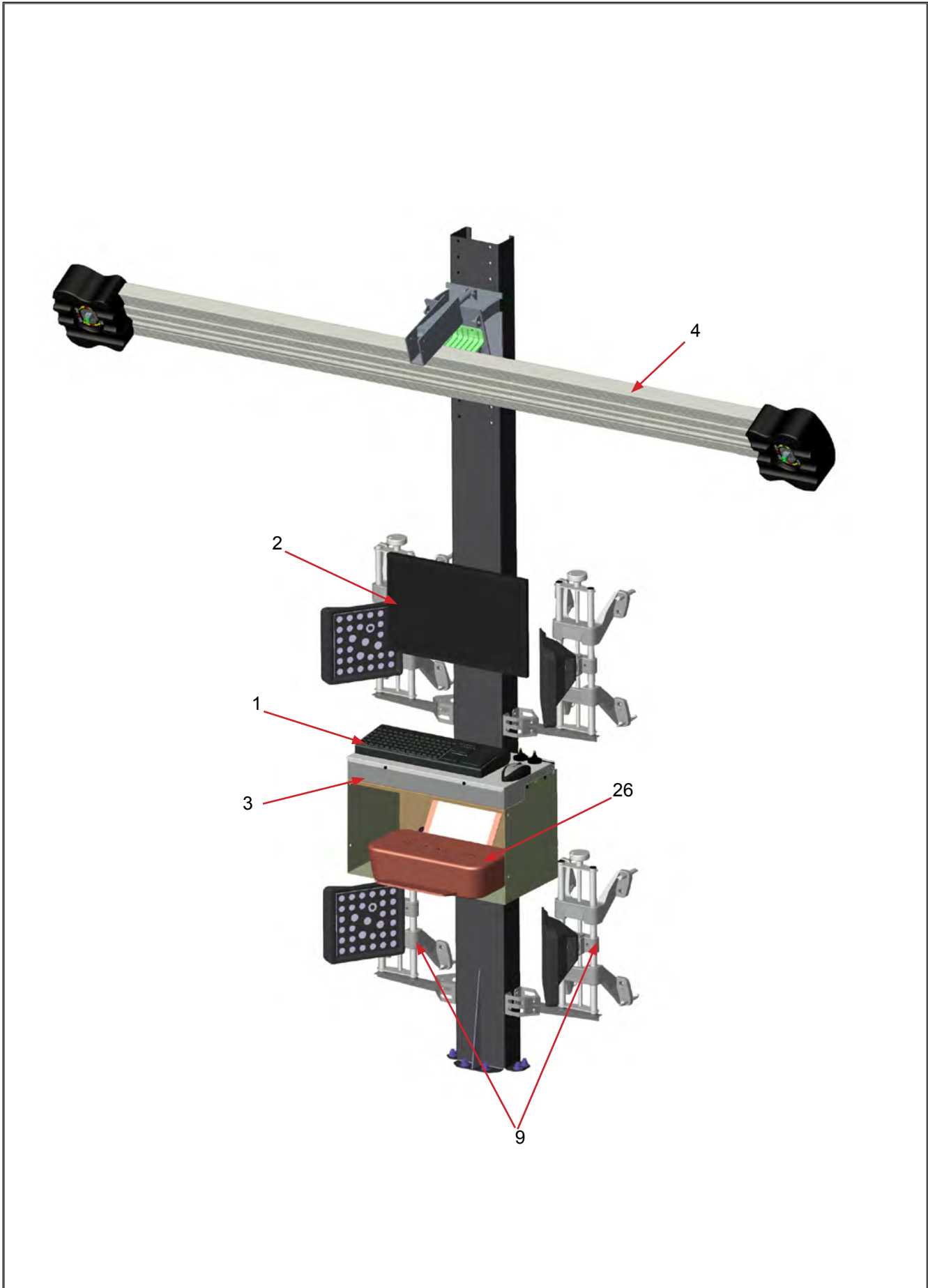

3

Part numbers and descriptions are for reference purposes only. Not all parts shown are stocked as service parts, consult your parts depot warehouse for availability.

## V2280 / GEO 660- BOM

REQ	ITEM	PART NUMBER	DESCRIPTION
1	1	3-08006A	KIT, MOUSE/KEYBOARD, USB
1	2	EAK0289J61A	KIT - 22" LCD MONITOR
		2-85466A	CABLE, HDMI-HDMI, 6FT
1	3	EAA0469J05A	ASSY., V2280 CABINET
		EAA0469J85A	ASSY., GEO660 CABINET
1	4	EAA0435V05B	BEAM ASM. – CAMERA
1	5	EAA0469J99A	ASSY., ELECTRICAL SHELF, V2280
1	6	EAK0277J82A	LIT PACK - GENERIC
1	7	EAK0256J96A1	KIT – DECAL, ULTRA, JBC
1	8	EAL0452J71A	DECAL – V2280
		EAK0268J10A	DECAL KIT, HOF
		EAL0452J72A	DECAL – GEO660
1	9	EAK0320J25A	KIT, AC200, XD, FRONT, 6X8
1	10	EAK0305J67A	KIT, AC200, XD, REAR, 6X8
1	14	EAW0290J26A	POWER CORD, 115V, 5M
1	15	55502	CLAMP ASM – WHEEL, STEERING
1	19	96	DEPRESSOR ASM - BRAKE
2	20	EAC0090J82A	WHEEL CHOCK, RUBBER
1	21	EAL0343J76A	LABEL-ELECTRICAL/ SERIAL
1	24	TEEWA544T0	INSTALLATIONS INSTRUCTIONS
1	25	ZEEWA544T1	MANUAL, QUICK START
1	26	EAK0268J05C	PRINTER KIT-TOP FEED
1	27	EAW0291V05A	ETHERNET CABLE, CAT5, 10M
1	29	EAS2186J15A	BRACKET, LCD MTG
7	30	1-16006A	SCREW, M5X12MM
4	31	1103959000	WASHER, FLAT M5
5	34	5-06945A	MOUNT, CABLE TIE
1	35	2-09457	METAL CLAMP
2	36	EAA0446J76A	HANGER ASSY., AC200
8	37	1-17609A	SCREW, SHCS, M8X16MM
1	40	EAC0105J41A	NAME PLATE, JBC
1	43	EAA0473J62A	ASSEMBLY, ELECTRICAL BOX, BOOM
1	44	EAA0473J09A	KIT, MOVEABLE BEAM (OPTION)

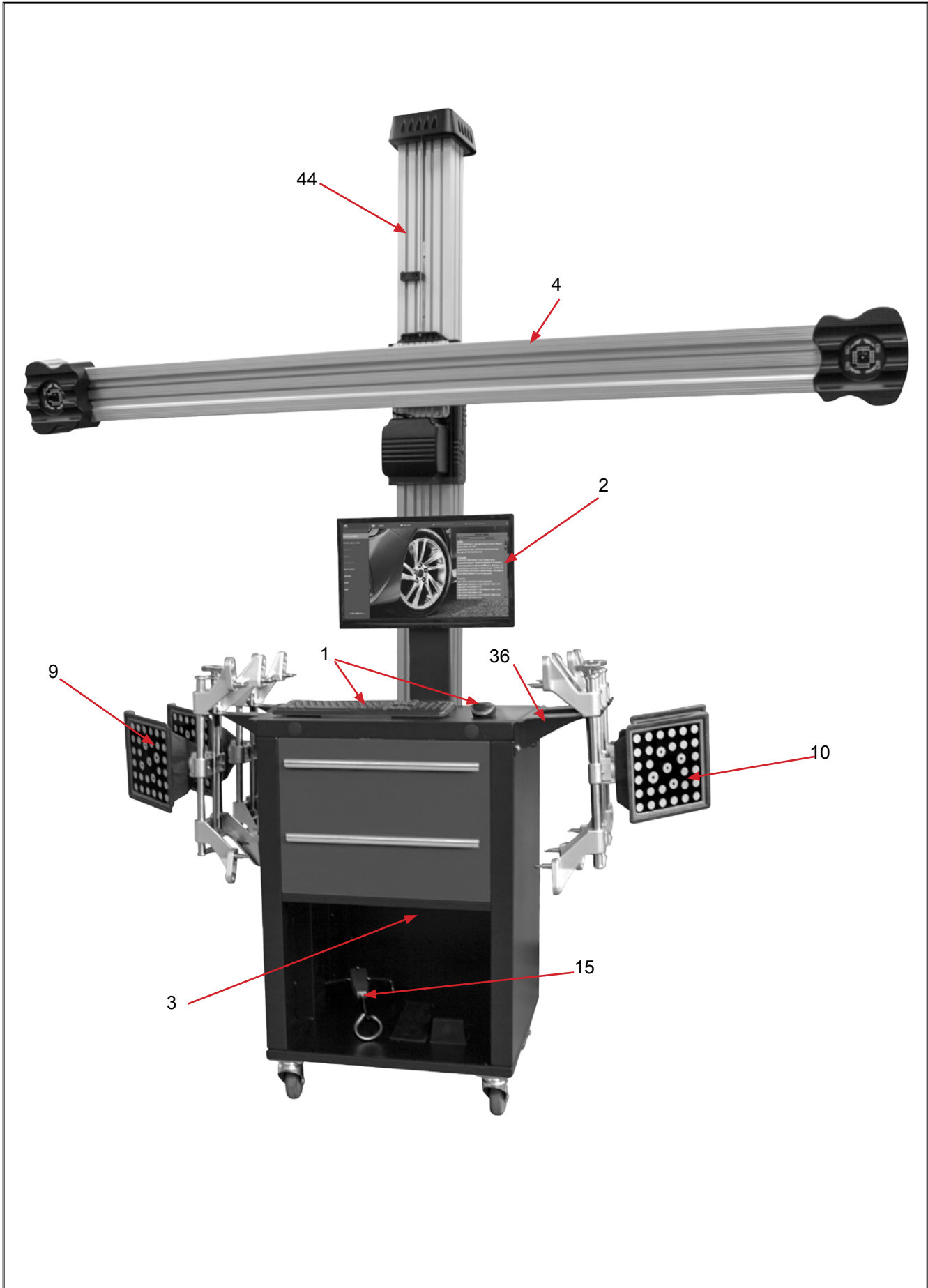

Part numbers and descriptions are for reference purposes only. Not all parts shown are stocked as service parts, consult your parts depot warehouse for availability.

KIT, TILT BEAM TOWER  
EAK0289J79A

ITEM	REQ	PART NUMBER	DESCRIPTION
1	4	EAS2119J04A	BRACKET – HANGER, POST
* 3	24		PLUG – HOLE, 3/8" HOLE DIAMETER
4	1	EAS2119J18A	TOWER – TILT BEAM, WELDMENT
7	4	EAC0090J84A	BRACKET – HANGER, WHEEL CLAMP
* 8	6		PLUG HOLE – NUT COVERS
* 9	4		CABLE - TIE
* 10	4		CABLE – TIE MOUNT, 4 WAY
14	6	8-02440A	STUD – ANCHOR BOLT
16	16	1-54009A	SCREW – BHC, 5/16-18
* 18	10		TIE CABLE (BLACK)
* 20	16	1-16006A	SCREW – PHM, M5 X 12MM
* 21	16	1-13633A	BARB NUT – M5
* 22	8	1-1337	NUT – ESNA, 5/16
* 23	16	1-10041	WASHER – FLAT, 5/16
* 24	1 FT		TAPE – VELCRO, 1" LOOP (BLACK)
* 25	1 FT		TAPE – VELCRO, 1" HOOK (BLACK)
* 27	4		MOVEABLE BOOM INSERTS
* 28	5		SHIM – 1/16 THK.
* 29	5		SHIM – 1/8 THK.
30	1	EAA0353J73A	TILT BEAM ASY
* 31	1	2-56166A	PSU 115V, LINEAR ACTUATOR
* 34	1	89209	CORD, POWER ADAPTER 12"
* 35	1	EAA0361J00A	CONTROL PENDENT
*	NOT SHOWN		



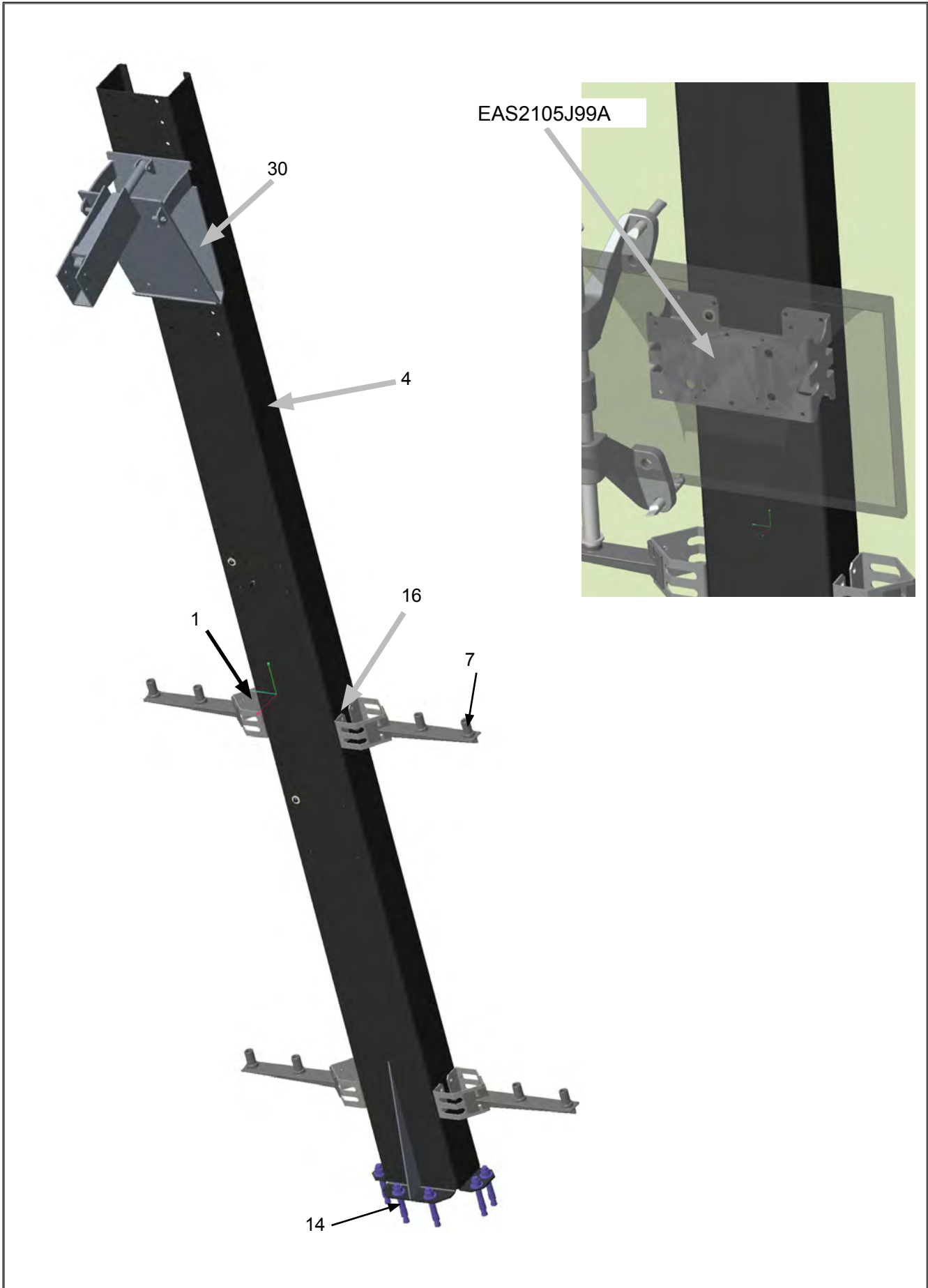

**KIT, MOVEABLE BEAM**  
EAA0473J09A

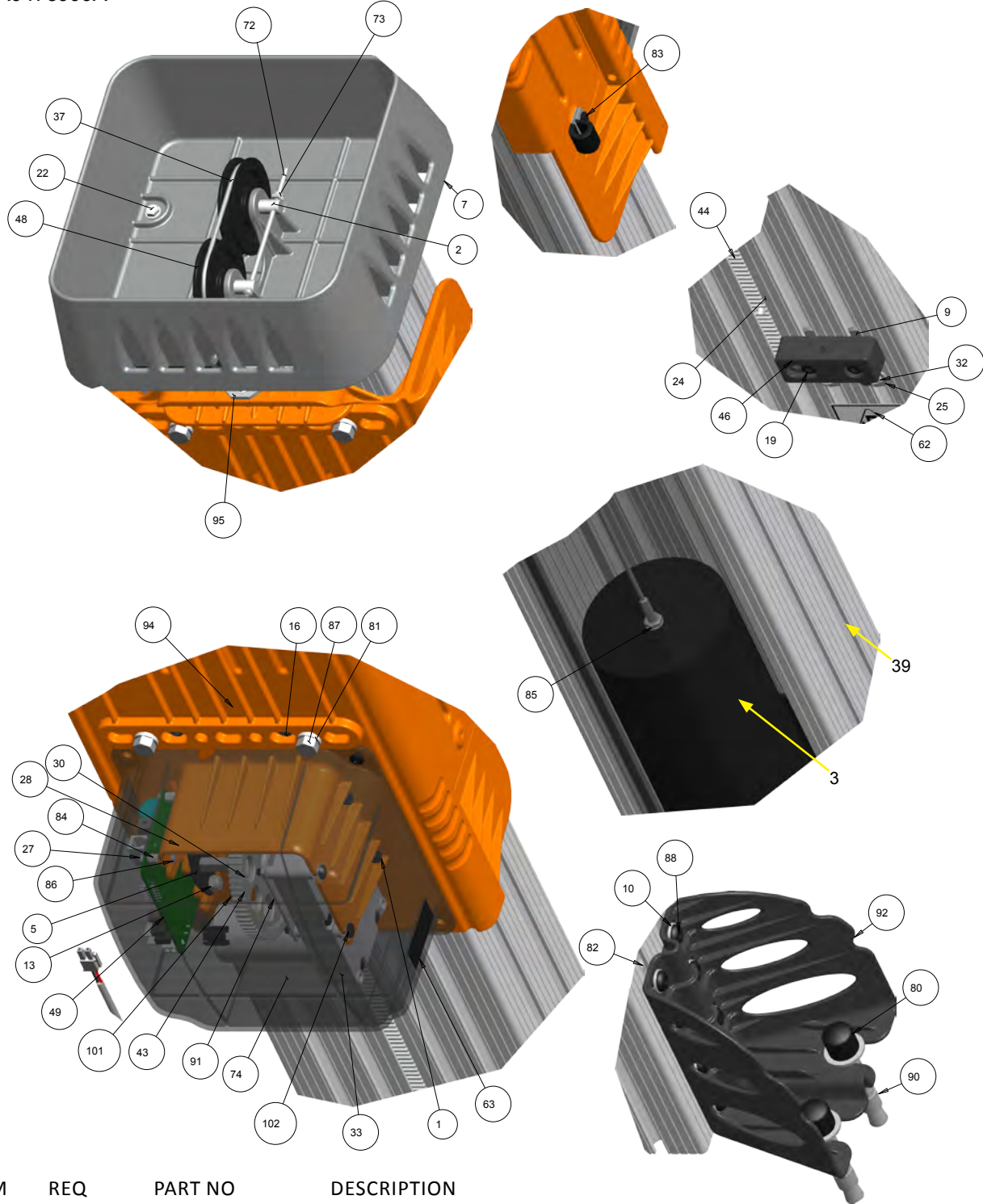

SYM	REQ	PART NO	DESCRIPTION
1	2	1-53401A	SCREW - SHC, #10-32 X 1 3/4
2	2	1-03955A	CLEVIS PIN, ULTRA
3	1	EAA0361J60A	ASSY., COUNTERWEIGHT MOVEABLE BOOM
4	1	5-10426A2	TAPE-VELCRO 1" LOOP
5	1	1-02863A	BEARING- FLANGE MTD
6	1	2-09457	CLAMP METAL, 3/8
7	1	EAC0105J38A	BRACKET - CAST - TOP, UA2M
9	6	1-08508A	WELD NUT, DUAL TAB - 1/4-20

10	30	1-10041	WASHER - FLAT, 5/16
13	2	1-1437	NUT, NYLOCK #10-24
16	4	1-32806A	SCREW - PHMS #10-24 X 3/8
19	4	1-44009A	SCREW-BHCS, 1/4-20 X 7/8
22	4	1-48701A	SCREW-HHW, #10-24 X 5/8,
24	12	1-2506	MSCR PNH #6-32 X 1/2
25	2	1-541	WASHER STEEL
27	3	1-6933	NUT & L/WASHER ASSY 4-40
28	2	1-7106	MSCR PNH #10-24 X 1/2
30	1	1-7433	NUT & L/WASHER ASSY, 1/4-20
32	2	1-806	MSCR PNH 1/4-20 X 3/8
33	1	2-89166A	GEAR MOTOR, 12VDC
37	1	EAA0321J17A	CABLE ASM.- ULTRA, WEIGHT
*	1	EAC0079J28A	COVER - MOTOR, ULTRA
39	1	EAM0054J64A	EXTRUSION - MAIN, 4 X 7
43	1	EAC0090J07A	SPUR GEAR- MOVEABLE, ULTRA
44	4	EAC0090J06A	RACK MOVE UA, IC
46	2	EAM0023J85A	STOP - LIMIT SWITCH
*	1	EAM0023J86A	BLACK COVER - CW, CUT ULTRA
48	2	EAM0044J05A	PULLEY- ULTRA MOVEABLE
49	1	EAP0295V09A	BOARD, MOTOR CONTROL
*	1	EAW0291V04A	MODULAR CABLE, 300MM
*	1	EAW0259P01A	CABLE ASS'Y MOTOR DRIVE
58	5	6-0739	SHIM PLATE .06 THK
59	5	6-0740	SHIM PLATE .125 THK
60	1	8-28560A	SKID-CAMERA BEAM
62	1	EAL0392J07A	LABEL- WARNING
63	1	EAL0392J11A	LABEL-PATENT EUROPE
64	1	8-36760A2	INSERT-CAMERA BEAM
72	1	1-30806A	SCREW-PHMS, 6-32 X 4,
73	1	1-737	NYLON INSERT NUT #6-32
74	1	EAL0343J76A	ELECT/SERIAL LABEL
80	6	1-04476A	PLUG HOLE-NUT COVERS
81	4	1-06747A	5/16, LOCKWASHER, INTERNAL TOOTH
82	12	1-08039A	NUT-DOUBLE
83	3	1-10124A	SCREW - PHM, #10-14 THREAD FORM, TRI.
84	3	1-15761A	STANDOFF-3/16 HEX #4-40 X .50 MF
85	3	1-24533A	NUT - LOCK 1/4-20, THIN
86	3	1-27403A	PHMS, #4-40 X 3/8 W/ EXT LOCK WASH
87	4	1-52901A	SCREW - HEX HEAD 5/16-24 X 7/8"
88	24	1-54009A	SCREW - 5/16-18, BHC
90	6	8-02440A	STUD ANCHOR BOLT, 1/2 X 3.75"
91	1	EAA0321J63A	PLATE ASM. - MOTOR LOCK, UA
92	3	EAC0090J85A	BRACKET - CAST, TOWER, VA
*	1	EAC0090J86A	BRACKET - SLIDE CAR, UA2M
94	1	EAS2105J63A	PLATE - UA2M, BRACKET
95	1	EAS2105J66A	BRACKET - UA2M, CABLE MTG.
100	4	1101777	SCREW, BHCS 1/4 X 20
101	1	EAM0088J70A	SCREW-BHCS, 1/4-20 X 7/8,FLAT
102	2	1-4806	PAN HEAD MACHINE SCREW #10-32X1.75"
*		NOT SHOWN	

CAMERA BEAM  
EAA0435V05B

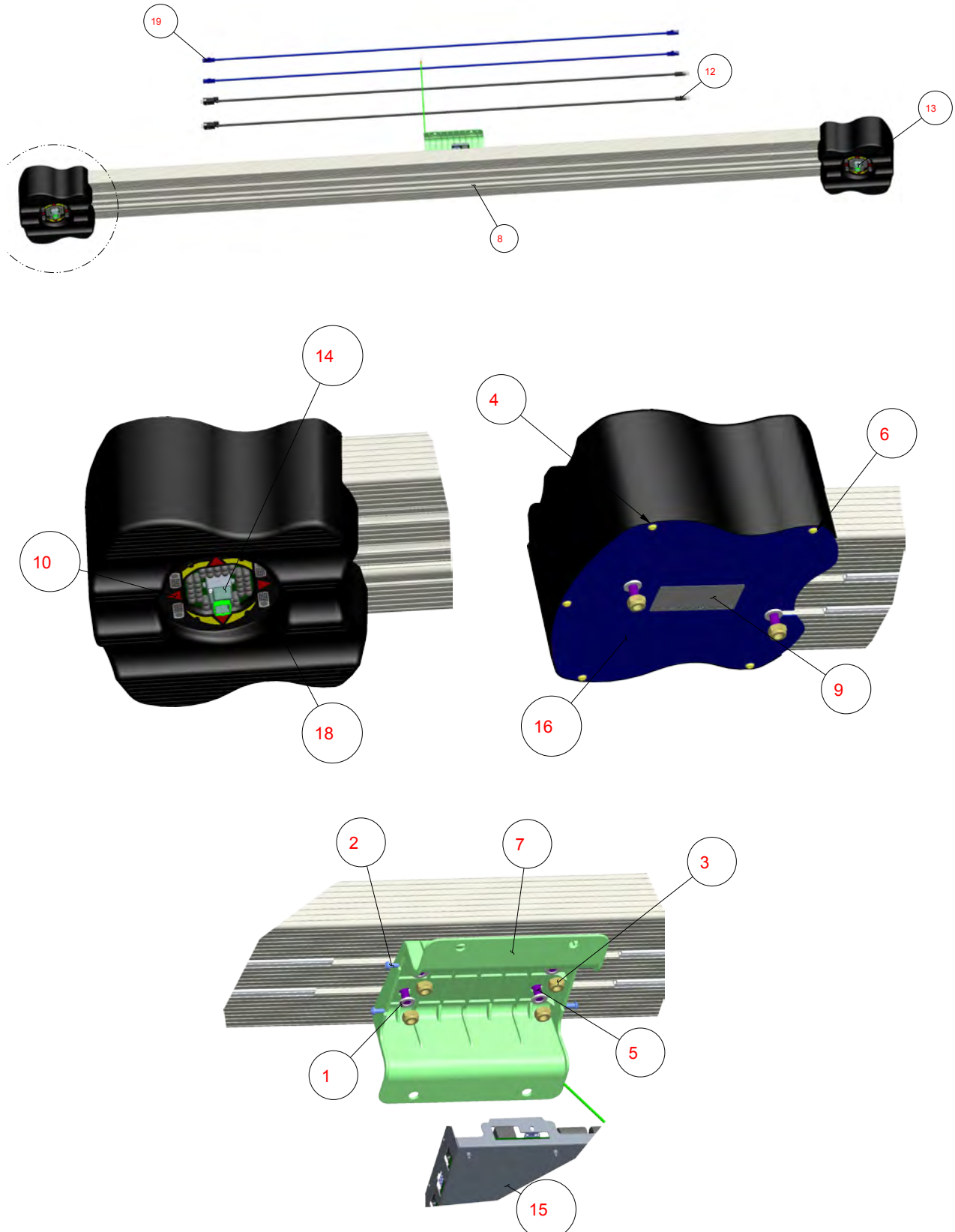

SYM	REQ	PART NO	DESCRIPTION
1	12		WASHER - FLAT,5/16
2	4		SCREW,SELF TAPPING M4.2X13MM DIN 7981
3	12		NUT - ESNA, 5/16 -18
4	10		MSCR PNH #6-32 X 3/8
5	12	1-705A	BOLT-CARRIAGE 5/16-18 X 3/4
6	10		LOCKWASHER, #6 EXTERNAL
7	1	EAC0124V05A	BRACKET - UA2, BEAM VA
8	1	EAC0090J95A	EXTRUSION - CAMERA, 2 X 7 CUT
9	1		ELECT/SERIAL LABEL
10	2	EAL0415J16A	VODI - UA2, UHR
* 11	4	EAM0023J47A	EXT-PLASTIC ,CROSS BEAM
12	2	EAW0391V02A	CABLE,POWER, DRAGON,1.6M
13	1	EAK0469J94A	ASM-CAMERA
14	1	EAK0469J94A	ASM-CAMERA
15	1		ASSY., PROCESSOR BOARD, V2100 ELS
16	2	EAS2173V01A	BACK PLATE, CAMER ASM
* 17	2		CABLE TIE
18	2	EAC0124V03A	CAMERA COVER, DRAGON
19	2	EAW0291V01A	ETHERNET CABLE CAT6A,LENGTH 1.6M

\* NOT SHOWN

SYM	REQ	PART NO	DESCRIPTION
1	4		SCREW - PHMS, M3 X 6MM
2	1		BARB NUT, M5
3	1		LOCKWASHER,INTERNAL TOOTH
4	1		LINK WIRE,GRN/YEL
5	1		HOUSING, PROCESSOR BOARD
6	1	EAK0469J95A	KIT - PROCESSOR, V2100
* 1	1	EAW0290J43A	CABLE, ETHERNET, CAT6A, 2.0M
* 1	1	EAE0049J84C	POWER SUPPLY, 19VDC, ISOLATED

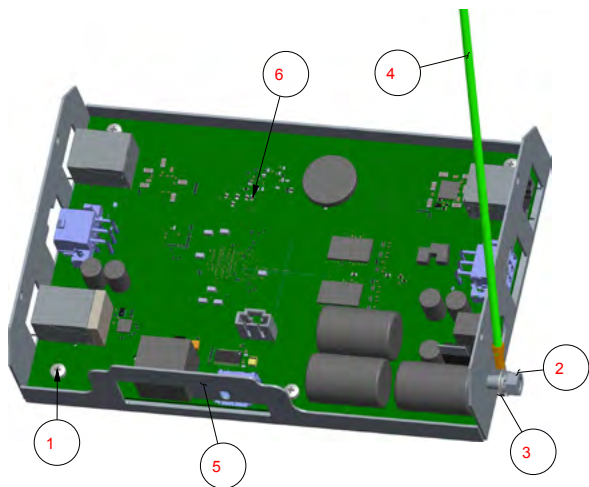

# SHELF ASSEMBLY 2100 / 630

SYM	REQ	PART NO	DESCRIPTION
1	4		SCREW, PAN HD M5X12 EXT.
2	2		GROUNDING SCREW 10-32X1/2"
3	4		#10 INTERNAL TOOTH LOCKWASHER
4	2		BUSHING - UNIVERSAL,
5	1	EAA0353J82B	BOX SHELF WELD V3D PC BOX
6	1	EAA0469J68A	ASSY., ELECTRICAL SHELF

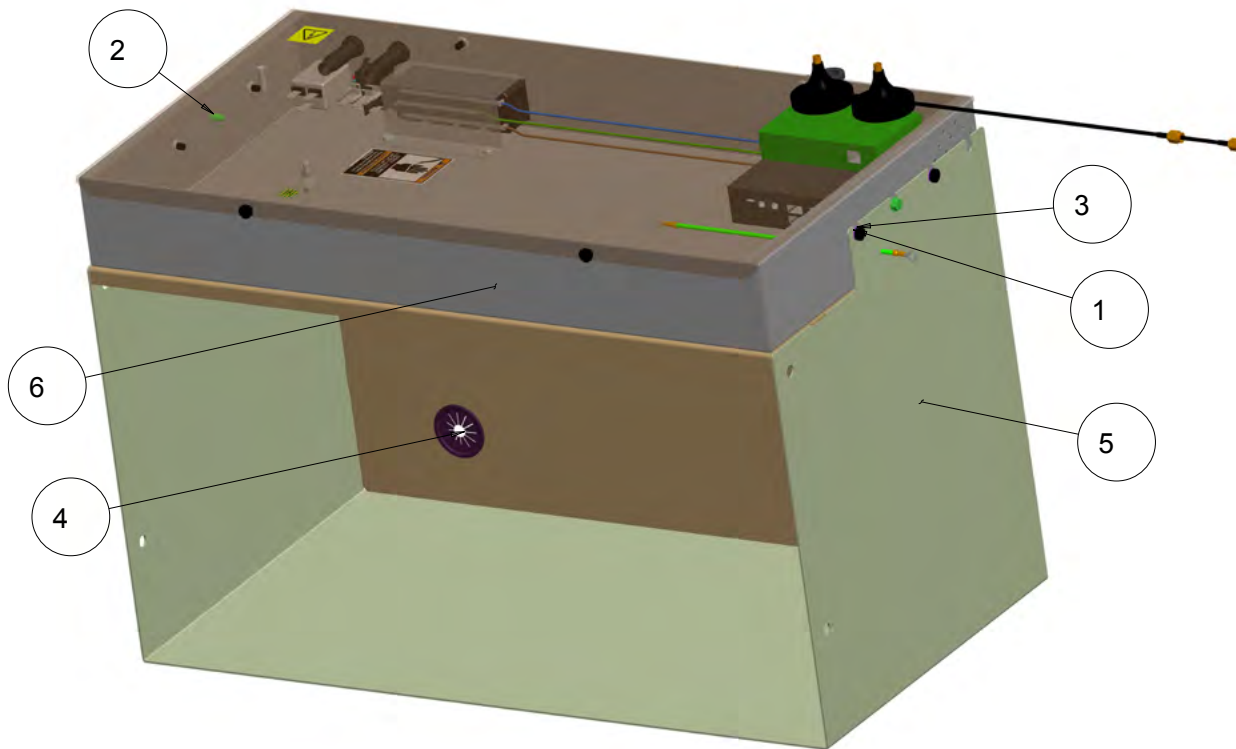

# CABINET ASSEMBLY 2280 / 660

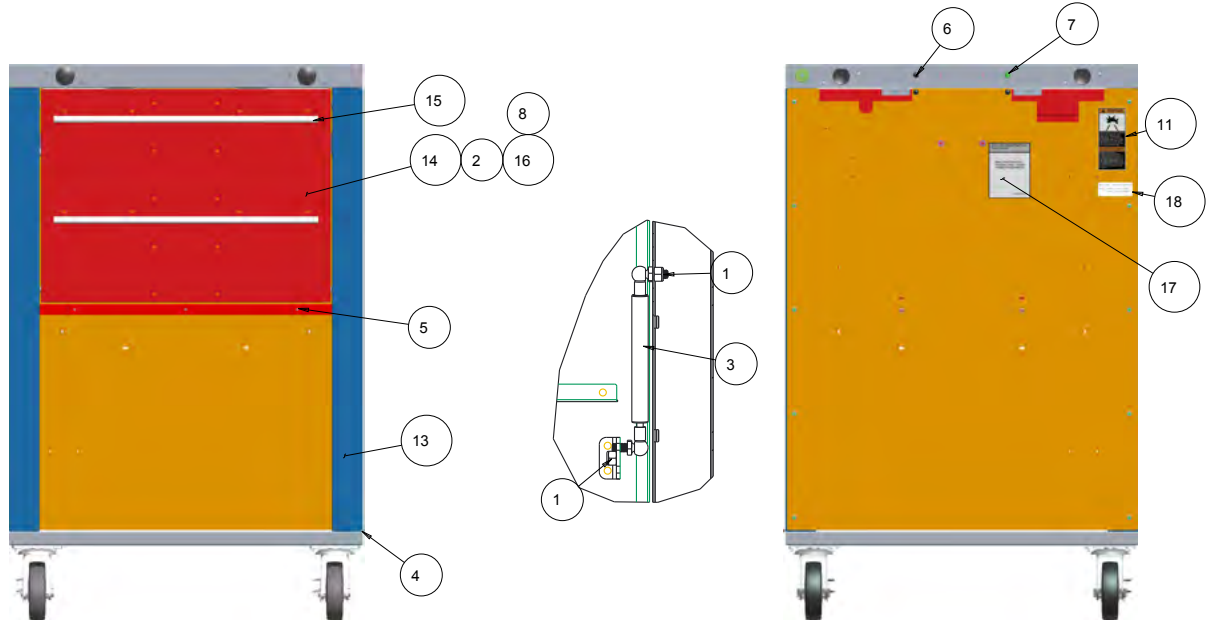

SYM	REQ	PART NO	DESCRIPTION
1	2		NUT-NYLON INSERT, 5/16-18
2	2		SCREW-PHM, M5X20MM,NYLOK
3	1	1-07969A	GAS SPRING
4	1		BARB NUT M5
5	3		HOLE PLUG- 1/8",BLK
6	4		SCREW - PHM, M5 X 12MM
7	1		GROUNDING SCREW 10-32X1/2"
8	2		BUSHING - SHOULDER
9	1		SKID-CABINET
10	1		CARTON-CABINET
11	1		LABEL-WARNING EXPLOSION
12	1	EAA0395J66A	PC-IN-BOX,PRO42
13	1	EAA0469J04A	CABINET ASM- V2280 BASE
14	1	EAA0469J17A	PRINTER DOOR ASM-JBC
15	2	EAC0121V05A	DOOR TRIM, FRONT
16	2	EAC0121V09A	INSERT,PRINTER DOOR
17	1	EAL0392J18A	LABEL-PATENT ALIGNMENT
18	1	EAL0392J89A	LABEL-CUSTOMER SERVICE JBC
19	1	EAW0243P25A	LINK WIRE, GRN/YEL

ELECTRICAL BOX - V2100 / GEO 630

FOR SERVICE ORDER  
EAA0469J68A

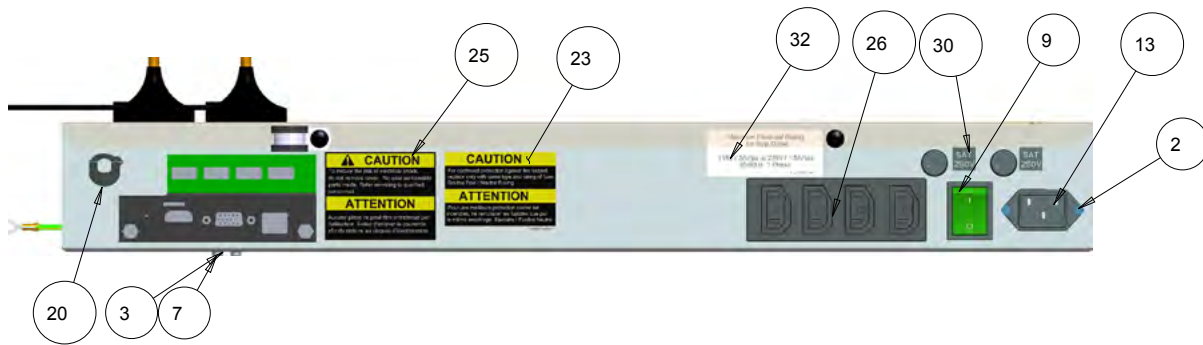
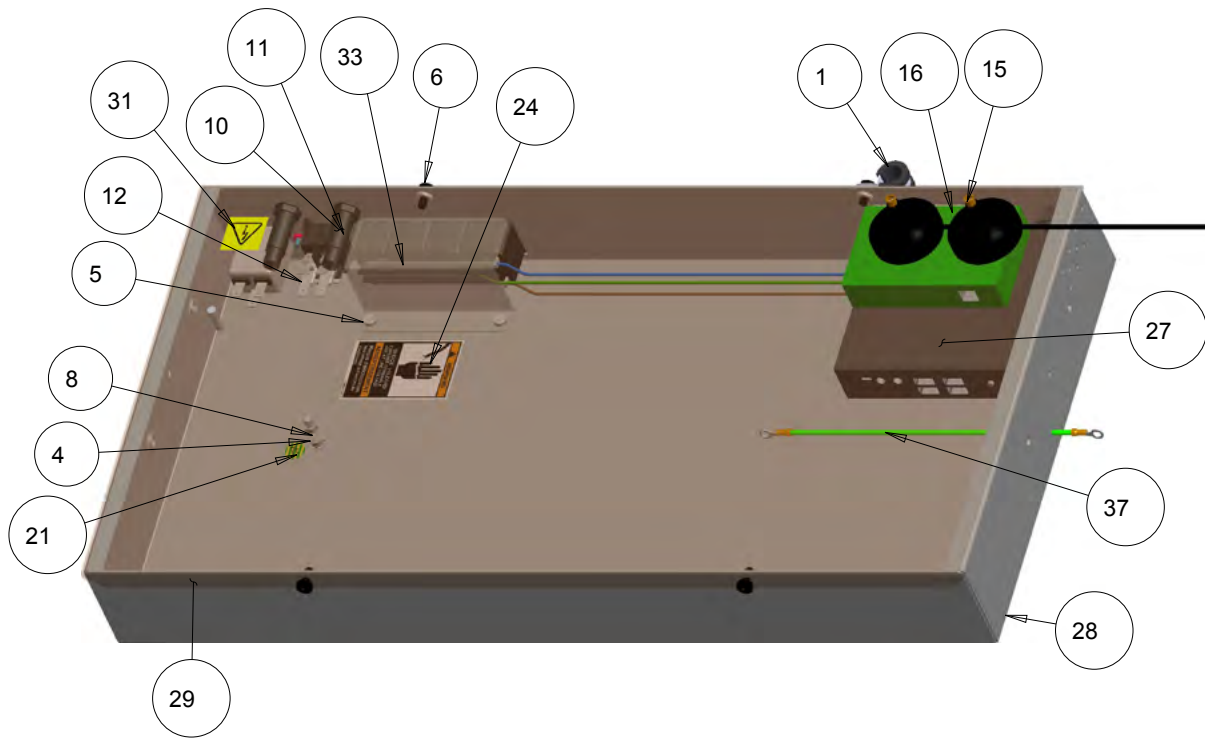



SYM	REQ	PART NO	DESCRIPTION
1	1		CLAMP METAL, 3/8
2	2		M3 X 10MM FLAT HEAD SCREW
3	2		WASHER SHAKE PROOF, M3
4	2		BARB NUT M5
5	2		NUT-KEPS, M3 - .5
6	4		SCREW, PAN HD M5X12 EXT.
7	2		SCREW - PHM, M3 X 10MM
8	6		LOCKWASHER, INTERNAL TOOTH
9	1	2-14258A	ROCKER SWITCH, ILLUMINATED, GREEN
10	2	2-15651A	FUSE HOLDER
11	2	2-18451A	FUSE - 5A SLOW BLOW
12	4	2-31001A	TERMINAL - QUICK CONNECT
13	1	2-37348A	AC RECEPTACLE & LINE FILTER (IEC)
*	14	2-78266A	RECPT, NEMA 5-15 TO IEC
	15	2-78566A	BASE-ANTENNA, MAGNETIC
*		EAE0049J99B	ANTENNA DUAL BAND
	16	3-18006A	USB HUB-4 PORT,POWERED
*	17		CABLE - TIE MOUNT - 4 WAY
	18		VELCRO LOOP-LAPTOP ADAPTOR
	19		VELCRO HOOK-LAPTOP ADAPTOR
	20		STRAIN RELIEF .22-.29" DIA WIRE
	21		LABEL - EARTH SYMBOL
*	22		TIE CABLE (BLACK)
	23	86164	LABEL-WARNING, FUSE RATING
	24	86465	LABEL-WARNING, SHOCK HAZARD
	25	00111245000	LABEL CAUTION ELECTRICAL
	26	EAA0261P60B	POWER STRIP - 4 CON
	27	EAA0469J23C	ASSY., GIADA F210, V2100
	28	EAA0469J69A	BOX ASSY., ELECTRICAL
	29	EAA0469J72A	COVER ASSY, ELEC SHELF V2100 ELS
	30	EAL0345P51A	LABEL FUSE 5 A
	31	EAL0345P54A	ELECTRICAL WARNING LABEL
	32	EAL0415J15A	LABEL- ELECTRICAL RATING
	33	EAS2186J73A	COVER IEC OUTLET, 4-WAY
	34	EAW0235J36A	CABLE ASSY- GROUND, 12"
*	35	EAW0235J74A	CORD - POWER, PC IN BOX
*	36		LINK WIRE, BROWN
	37		LINK WIRE, BLUE
*	38		GRND WIRE-6 IN, GR/YL,16 AWG
*		NOT SHOWN	

ELECTRICAL BOX - V2280 / GEO 660

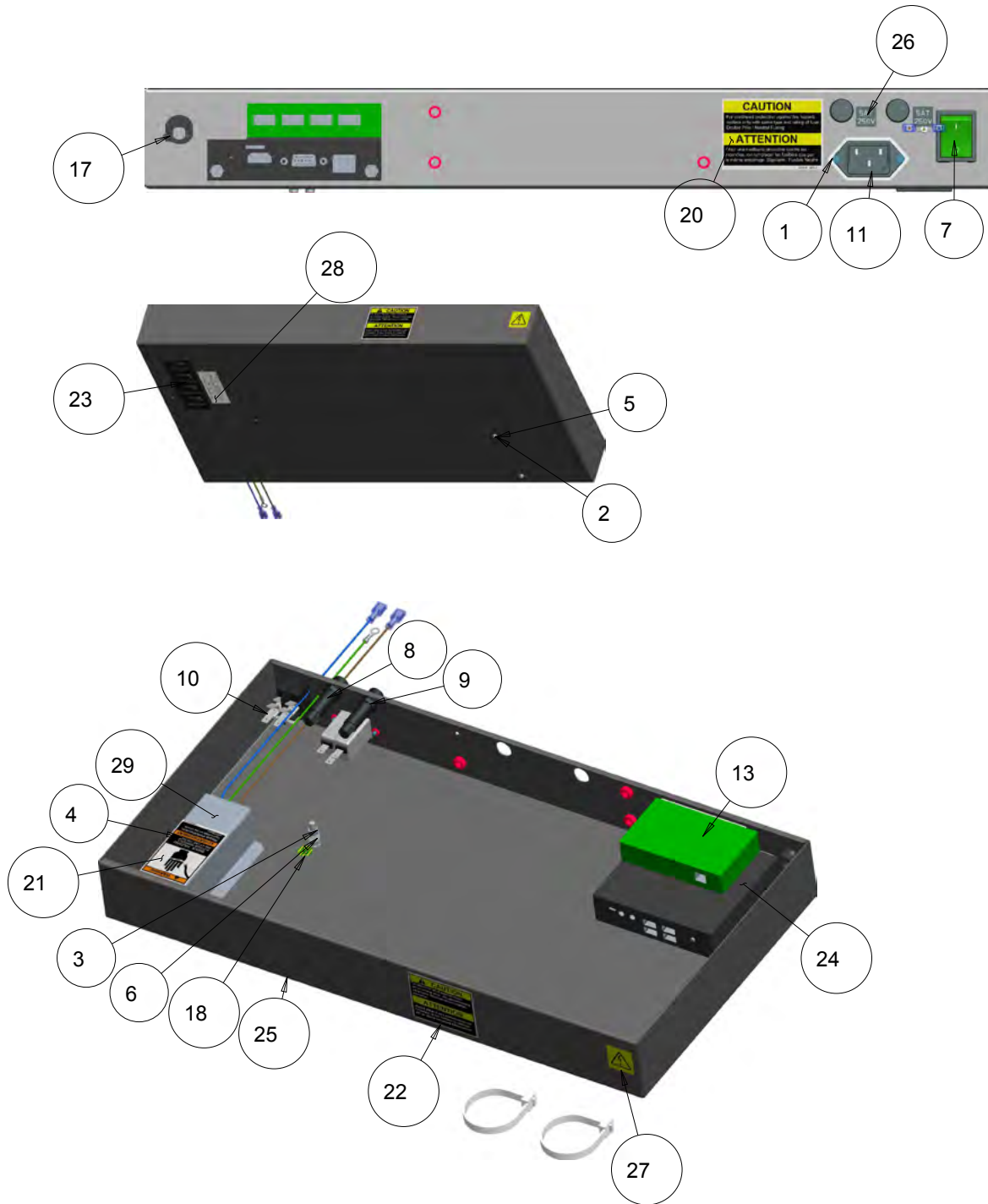

SYM	REQD	PART NO	DESCRIPTION
1	2		M3 X 10MM FLAT HEAD SCREW
2	2		WASHER SHAKE PROOF, M3
3	2		BARB NUT M5
4	2		NUT-KEPS, M3 - .5
5	2		SCREW - PHM, M3 X 10MM
6	5		LOCKWASHER, INTERNAL TOOTH
7	1	2-14258A	ROCKER SWITCH, ILLUMINATED, GREEN
8	2	2-15651A	FUSE HOLDER
9	2	2-18451A	FUSE - 5A SLOW BLOW
10	4	2-31001A	TERMINAL - QUICK CONNECT
11	1	2-37348A	AC RECEPTACLE & LINE FILTER (IEC)
12	1	2-78266A	RECPT, NEMA 5-15 TO IEC
13	1	3-18006A	USB HUB-4 PORT,POWERED
14	2		CABLE - TIE MOUNT - 4 WAY
15	1		VELCRO LOOP-LAPTOP ADAPTOR
16	1		VELCRO HOOK-LAPTOP ADAPTOR
17	1		STRAIN RELIEF .22-.29" DIA WIRE
18	1	8-23762A	LABEL - EARTH SYMBOL
19	5		TIE CABLE (BLACK)
20	1	86164	LABEL-WARNING, FUSE RATING
21	1	86465	LABEL-WARNING, SHOCK HAZARD
22	1	00111245000	LABEL CAUTION ELECTRICAL
23	1	EAA0261P60B	POWER STRIP - 4 CON
24	1	EAA0469J23C	ASSY., HOST CONTROLLER V2280 / GEO660
25	1	EAA0473J01A	ASY., ELECTRICAL BOX, V2280
26	2	EAL0345P51A	LABEL FUSE 5 A
27	1	EAL0345P54A	ELECTRICAL WARNING LABEL
28	1	EAL0415J15A	LABEL- ELECTRICAL RATING
29	1	EAS2105J96B	COVER - OUTLET
30	2	EAW0235J74A	CORD - POWER, PC IN BOX
31	2		LINK WIRE, BROWN
32	2		LINK WIRE, BLUE
33	1		GRND WIRE-6 IN, GR/YL,16 AWG

# ELECTRICAL BOX - V2280 / GEO 660

EAA0473J62A - ASSY., ELECTRICAL BOX

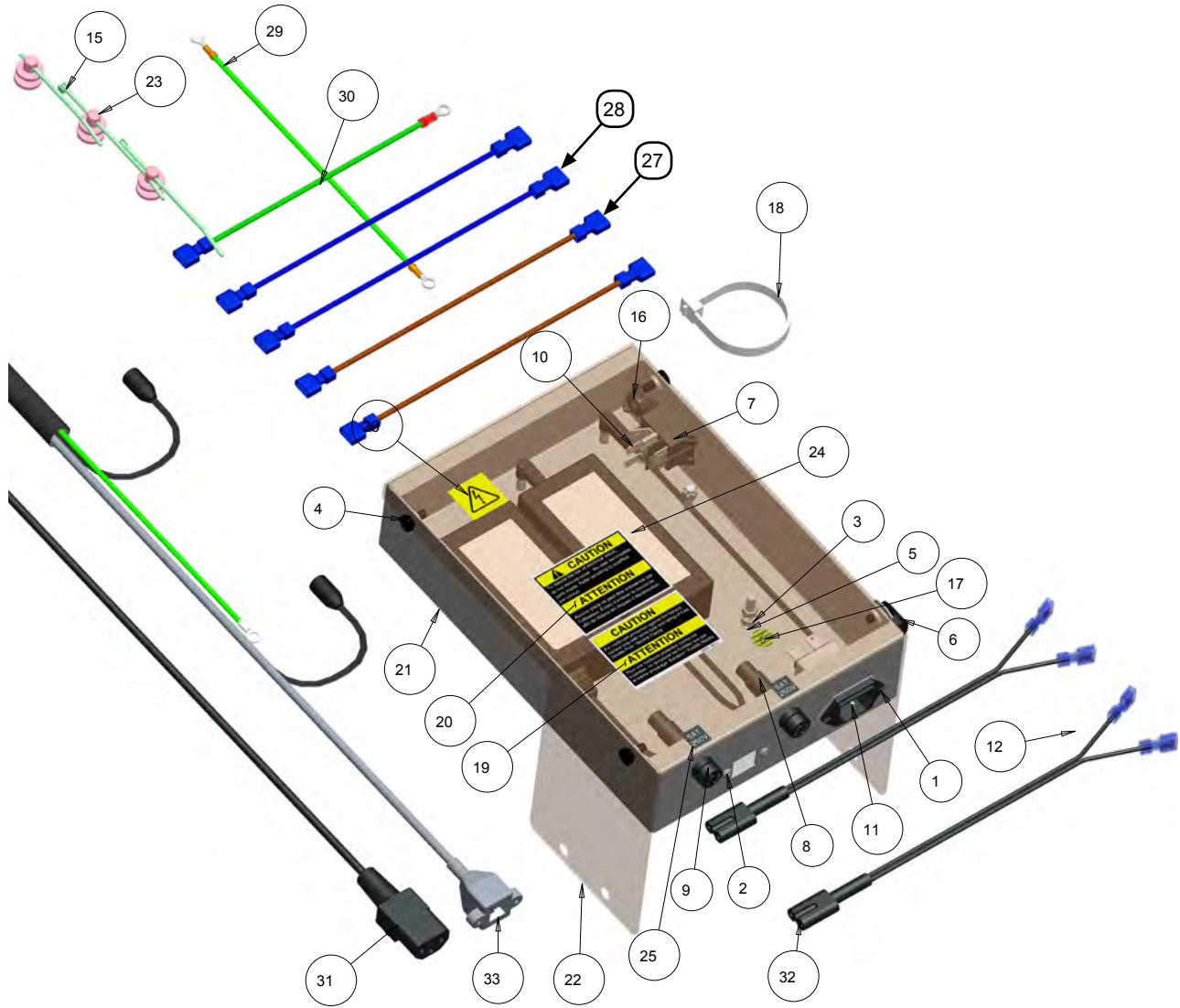

SYM	REQ	PART NO	DESCRIPTION
1	2	1-11103	M3 X 10MM FLAT HEAD SCREW
2	2	1-12224A	SCREW - THREAD FORMING, M3X0.5
3	3	1-13633A	BARB NUT M5
4	4	1-16006A	SCREW, PAN HD M5X12 EXT.
5	3	1-3347	LOCKWASHER, INTERNAL TOOTH
6	1	2-09457	CLAMP METAL, 3/8
7	1	2-14258A	ROCKER SWITCH, ILLUMINATED, GREEN
8	2	2-15651A	FUSE HOLDER
9	2	2-18451A	FUSE - 5A SLOW BLOW
10	2	2-31001A	TERMINAL - QUICK CONNECT
11	1	2-37348A	AC RECEPTACLE & LINE FILTER (IEC)
12	2	5-06945A	CABLE - TIE MOUNT - 4 WAY
13	1	5-14426A	VELCRO LOOP-LAPTOP ADAPTOR
14	1	5-14526A	VELCRO HOOK-LAPTOP ADAPTOR
15	3	5-2345	TIE - CABLE 4" LG X .10" WD
16	1	8-10319A	STRAIN RELIEF .38-.40" DIA, ROUND CABLE
17	1	8-23762A	LABEL - EARTH SYMBOL
18	4	4500-0029	TIE CABLE (BLACK)
19	1	86164	LABEL-WARNING, FUSE RATING
20	1	00111245000	LABEL CAUTION ELECTRICAL
21	1	EAA0473J63A	BOX ASSY., ELECTRICAL
22	1	EAA0473J64A	COVER ASSY, ELEC BOX V2280 BOOM
23	3	EAC0079J84A	RETAINER - CORD, ARAGO3
24	2	EAE0049J84C	POWER SUPPLY 19VDC
25	2	EAL0345P51A	LABEL FUSE 5 A
26	1	EAL0345P54A	ELECTRICAL WARNING LABEL
27	2	EAW0243P22A	LINK WIRE, BROWN
28	2	EAW0243P23A	LINK WIRE, BLUE
29	1	EAW0235J36A	LINK WIRE, GRN/YEL 12"
30	1	EAW0290J20A	GRND WIRE-6 IN, GR/YL,16 AWG
31	1	EAW0290J26A	POWER CABLE - 5 METERS
32	2	EAW0290J47A	CORD - POWER, IEC C7, FIGURE 8
33	1	EAW0290J50A	CABLE, MOVEABLE BOOM

WHEEL CLAMP (V2100 / GEO 630)

EAC0079J54A - WHEEL CLAMP ASSY FRONT

EAC0079J55A - WHEEL CLAMP ASSY REAR

EAC0079J74A WHEEL CLAMP IMAGE FRONT, SHORT (EUROPE)

EAC0079J75A WHEEL CLAMP IMAGE REAR, SHORT (EUROPE)

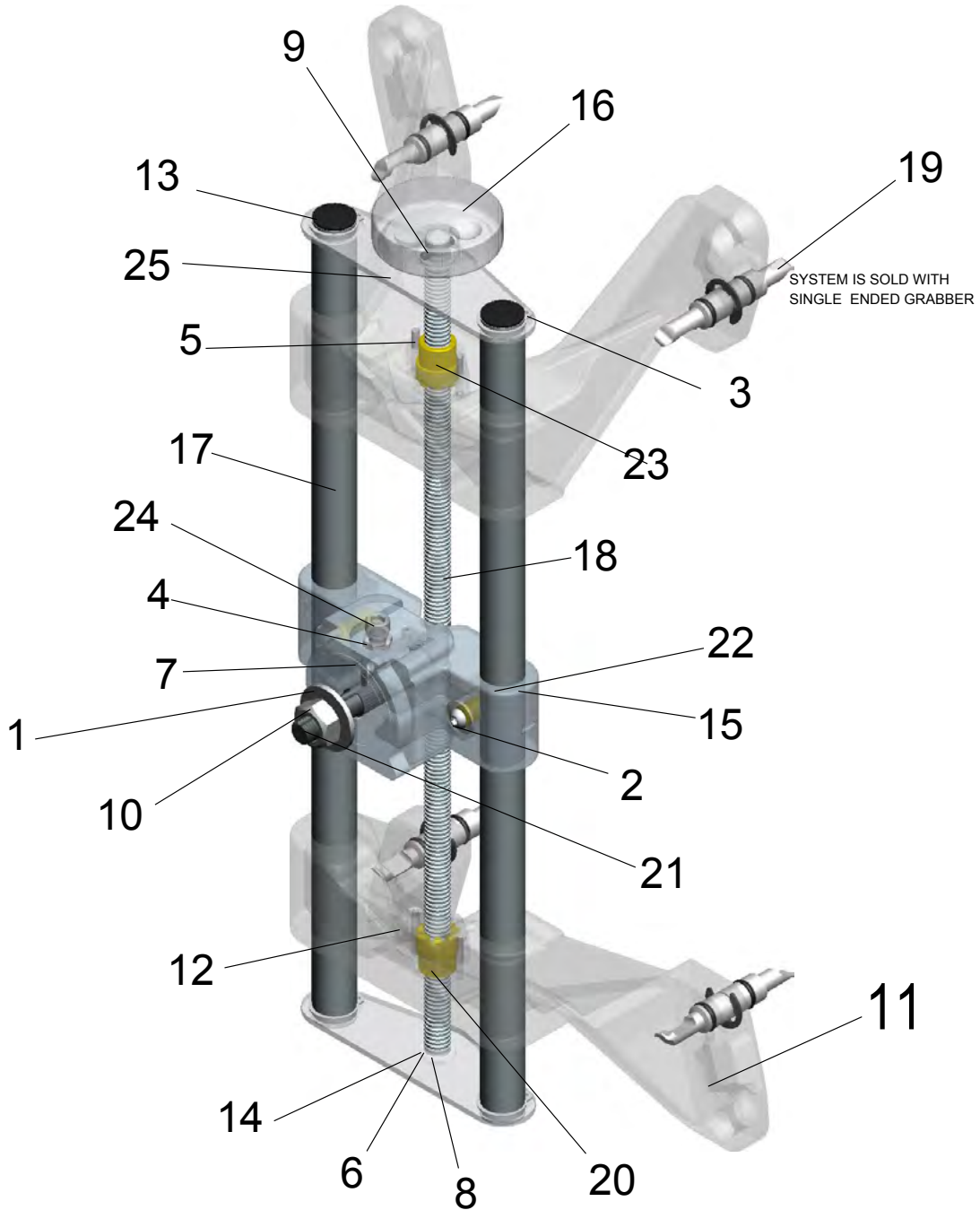

SYM	REQ	PART NO	DESCRIPTION
1	1	1-1041	WASHER - FLAT, 1/2
2	3	1-14144A	WASHER-FLAT, M6
3	8	1-17677A	RETAINING RING
4	1	1-20733A	NUT - JAM, M8
5	4	1-26506A	SCREW-PH COUNTER SINK M4X20
6	1	1-3447	LOCKWASHER, INTERNAL TOOTH
7	1	1-37410	SCREW-SET M3 X .5 X 10MM, CUP PT.
8	3	1-50309A	SCREW-BHCS M6X10MM
9	1	1-6152	PIN-STRAIGHT SLOTTED
10	1	1-933	NUT-HEX, 1/2-13
11	2	EAC0079J48A	BRACKET-LONG WHEEL CLAMP (FRONT CLAMP)
		EAC0079J56A	BRACKET-SHORT WHEEL CLAMP (REAR CLAMP)
12	2	EAC0079J50A	COVER-FEED SCREW LOCK
13	2	EAC0079J51A	PLUG - PLASTIC, 19MM HOLE
14	2	EAC0079J52A	WASHER-THRUST PLASTIC PLASTIC, 19MM HOLE
15	1	EAC0079J53A	CENTER SLIDE BRACKET
16	1	EAM0044J13A	KNOB HAND WHEEL
17	2	EAM0044J14A	TUBE-WHEEL CLAMP LONG (NA)
		EAM0044J64A	TUBE-WHEEL CLAMP SHORT (EURO)
18	1	EAM0044J16A	SCREW-DOUBLE LEAD LONG (NA)
	1	EAM0044J65A	SCREW-DOUBLE LEAD SHORT (EURO)
21	1	EAM0044J21A	CENTER STATIONARY
22	2	EAM0044J22A	PIN-TUBE LOCK
23	1	EAM0044J24A	BUSHING THREADED BRASS LH
		EAM0044J20A	BUSHING THREADED BRASS RH
24	1	EAM0044J47A	SCREW - SHCS M8X30 FULL THD
25	2	EAS2084J29A	PLATE-RETAINER

EAK0350J22A - RIM CLAMP / TARGET ASSEMBLY (ALL 4 WHEELS)

REQD	PART NO.	DESCRIPTION
2	EAA0435V11A	TARGET MTG ASSY-FRONT
4	1-08584A	CORD-BUNGEE, BLACK 16"
2	EAA00435V12A	TARGET MTG ASSY-REAR
4	EAK0268J41D	KIT GRABBER, SINGLE END

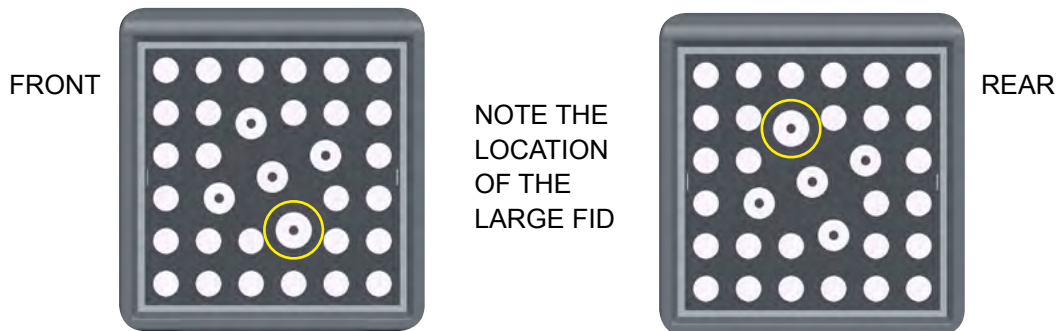

TILT MECHANISM  
EAA0353J73A

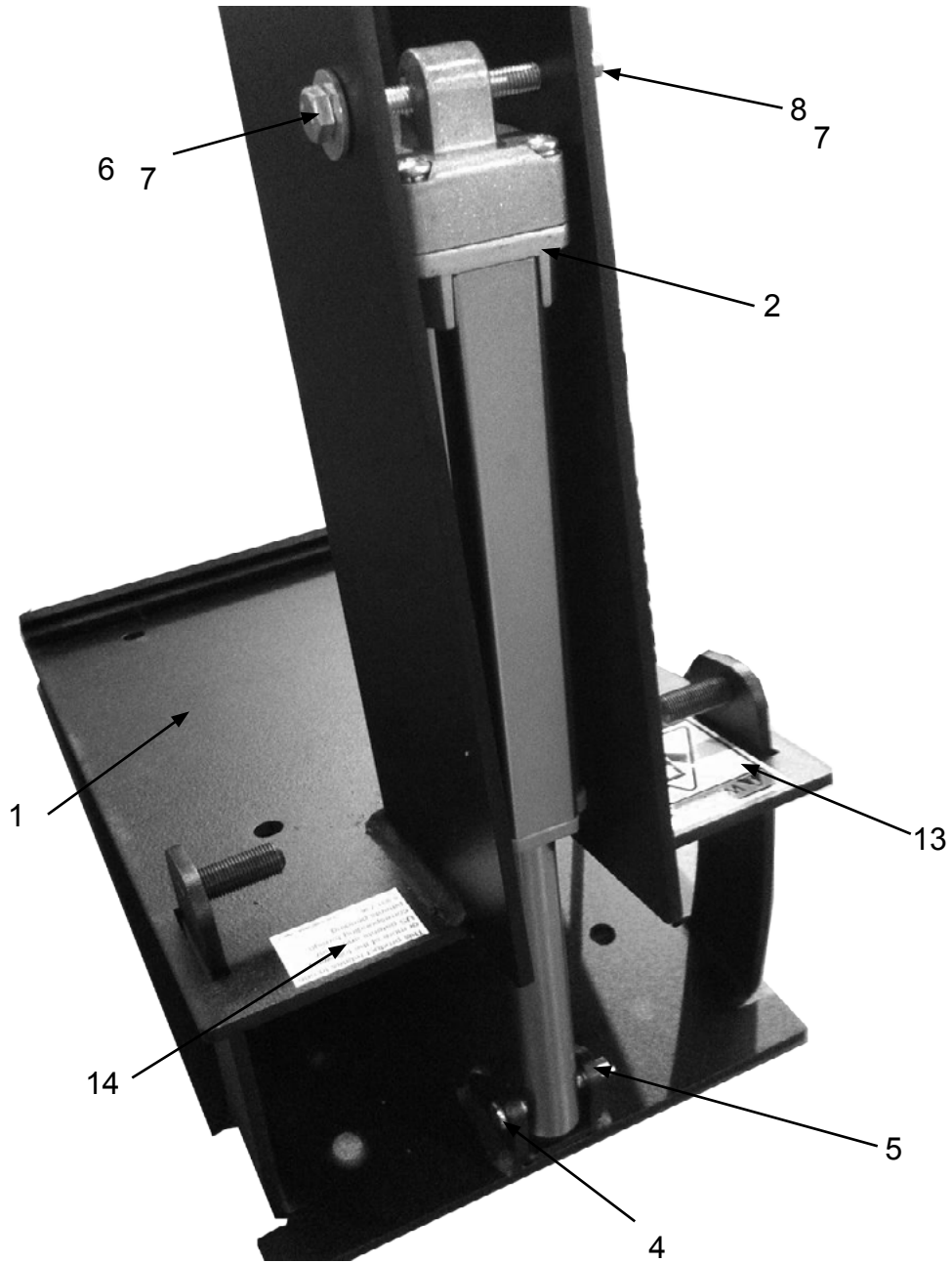



ITEM	REQ	PART NUMBER	DESCRIPTION
1	1	EAA0353J71B	ASSY., TILT PLATES
2	1	2-56366A	LINEAR ACTUATOR 100MM STROKE
4	1	1-03455A	CLEVIS PIN 1/4"X 1-1/2"
5	1	1-03555A	COTTER PIN 1/16" X 1"
6	1	1-31801	SCREW-HHMS M6 X 65
7	2	1-20041A	WASHER - FLAT M6.4X18X1.6
8	1	1-01637A	NUT-ESNA M6 X 1MM
* 9	1	EAS2105J74A	END CAP
* 10	1	1-3724	SCREW – M5X10 THREAD FORMING
11	4		BACKING
12	4		CABLE TIE
13	1		PINCH POINT LABEL
14	1		PATENT LABEL
* 15	4	1-58909A	SCREW - 5/16"-18 X1"
* 16	4	1-2541	WASHER - FLAT 5/16
* 17	4	1-1337	NUT – ESNA 5/16-18
* PART NOT SHOWN			

**WHEEL CLAMP 2280 / 660** (SEE BREAKDOWN PG20)

EAA0395J10A - WHEEL CLAMP ASSY LF 2280 / 660

EAA0395J14A - WHEEL CLAMP ASSY RF 2280 / 660

EAA0381J24A - WHEEL CLAMP ASSY LR 2280 / 660

EAA0381J23A - WHEEL CLAMP ASSY RR 2280 / 660

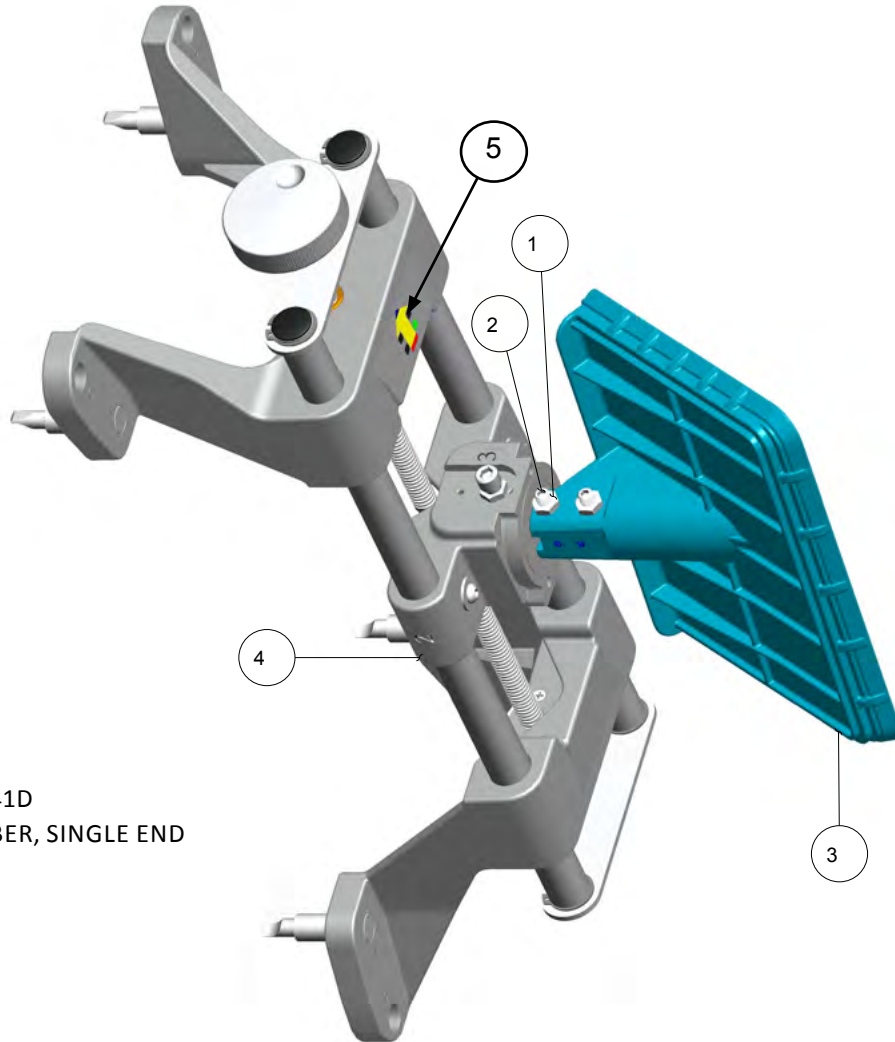

EAK0268J41D  
KIT GRABBER, SINGLE END

SYM	REQ	PART NO	DESCRIPTION
1	2	1-20733A	NUT - JAM, M8
2	2	1-54810A	SCREW - SET. M8 X 20MM, CONE PT
3	1	EAA0381J35A	XD TARGET ASM - REAR 6X8
		EAA0395J13C	XD TARGET ASM - FRT 5° 6X8
4	1	EAC0079J54A	V3D FRT WHEEL CLAMP ASM (NA LONG)
		EAC0079J74A	V3D FRT WHEEL CLAMP ASM (EU SHORT)
5	1	EAL0415J11A	DECAL - RR, INDICATOR
		EAL0415J09A	DECAL - LF, INDICATOR
		EAL0415J10A	DECAL - LR, INDICATOR

REQ	PART NO.	DESCRIPTION
4	1-08584A	CORD-BUNGEE, BLACK 16"



Notice: The information contained in this document is subject to change without notice. Snaon makes no warranty with regard to this material. Snaon shall not be liable for errors contained herein or for incidental consequential damages in connection with furnishings, performance, or use of this material.

This document contains proprietary information which is protected by copyright and patents. All rights are reserved. No part of this document may be photocopied, reproduced, or translated without prior written consent of Snaon.