

Подъемник двухстоечный 380V NORDBERG N4122A-5T

T50E	
A	Column
B	Carriage
C	Lifting arm
D	Baseplate
E	Main oil cylinder
F	Sub oil cylinder
G	Wire rope
H	Oil pipes
I	Power unit
J	Control box

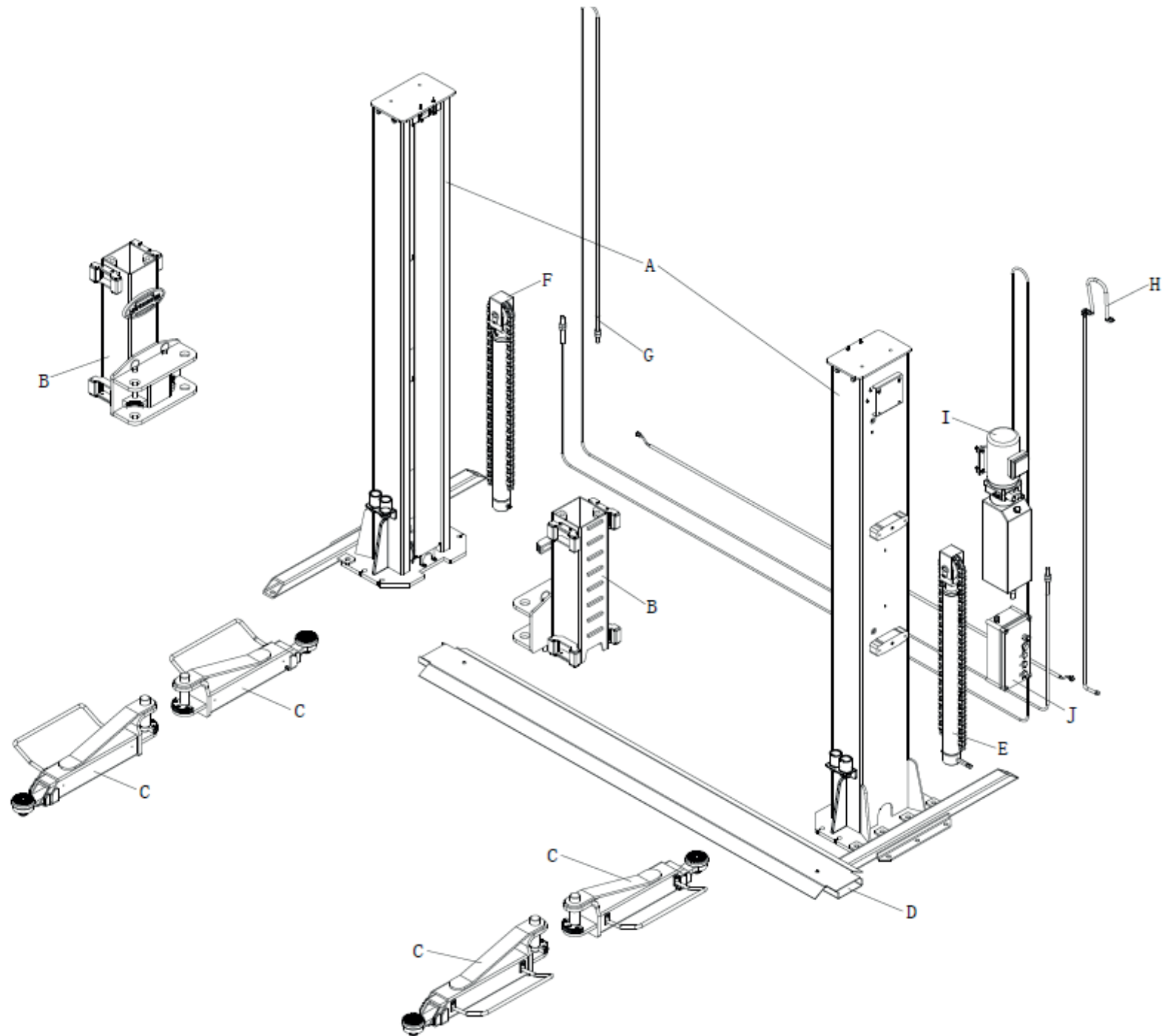

A

T50E/201809

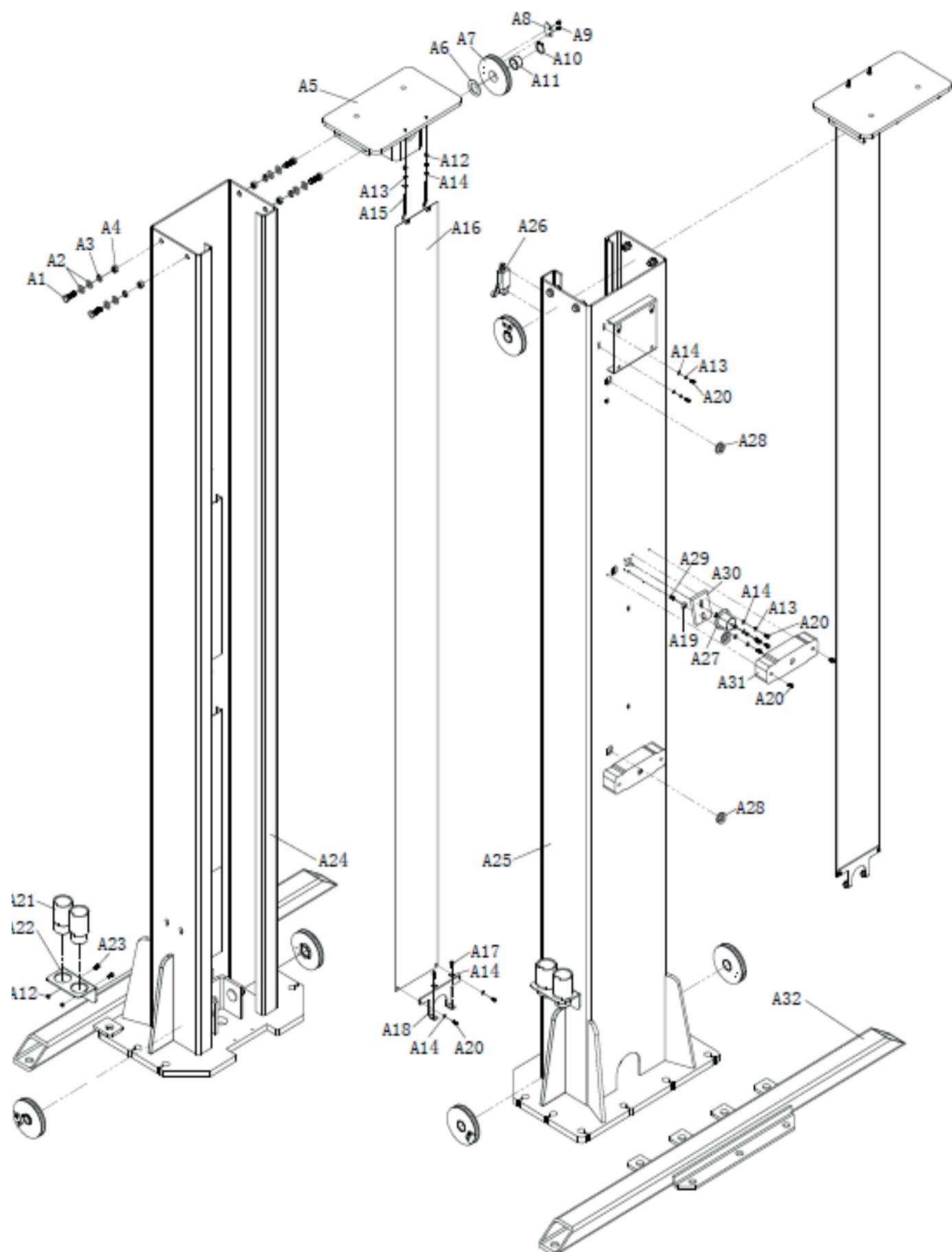

A1	hexagon head bolt full thread M12×35
A2	plain washer Ø12
A3	spring washer Ø12
A4	hexagon nut M12
A5	top plate assembly
A6	washer
A7	roller
A8	steel cable damper
A9	hexagon head bolt full thread M5×10
A10	circlip for shaft Ø30
A11	shaft sleeve 343018
A12	hexagon nut M6
A13	spring washer Ø5
A14	plain washer Ø5
A15	dust cloth hanger
A16	dust cloth
A17	hexagon socket head cap screw M6×12
A18	dust cloth fixed plate
A19	small insurance block
A20	cross recessed pan head screw M5×12
A21	higher column 70
A22	higher column support
A23	cup head square neck screw with large head M6
A24	main column assembly
A25	sub column assembly
A26	limit switch
A27	electromagnet MQZ2-10
A28	coil
A29	cross recessed pan head screw M5×16
A30	insurance block
A31	decorate box
A32(optional)	foundation pressure bar assembly

B

T50E/201809

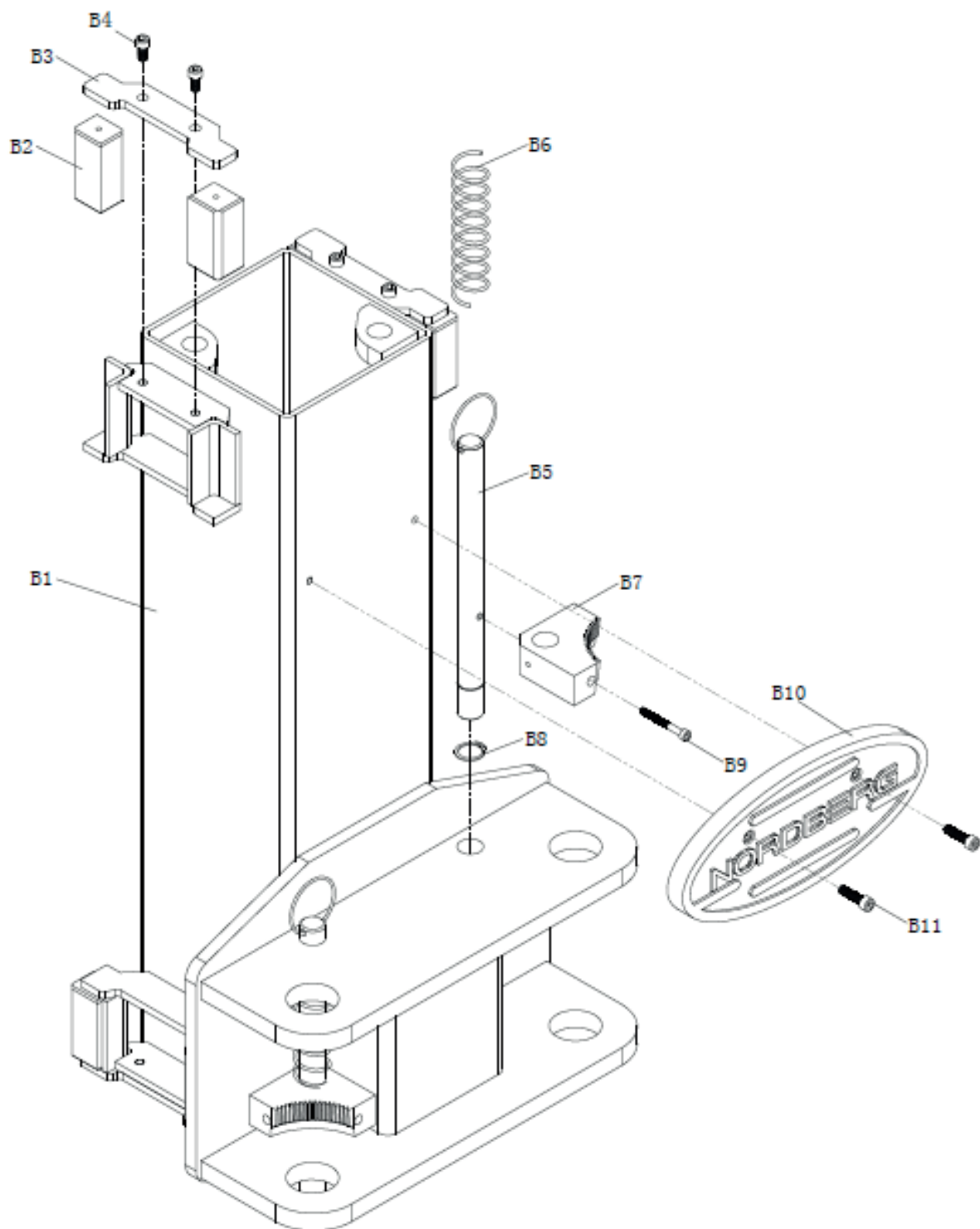

B1	carriage assembly
B2	slider
B3	slider baffle
B4	hexagon socket head cap screw M8×16
B5	locking shaft assembly
B6	locking shaft spring
B7	lock tooth block(inner circle)
B8	circlip for shaft Ø25
B9	hexagon socket head cap screw M6×55
B10	protection rubber mat
B11	hexagon socket head cap screw M8×30

C
T50E/201809

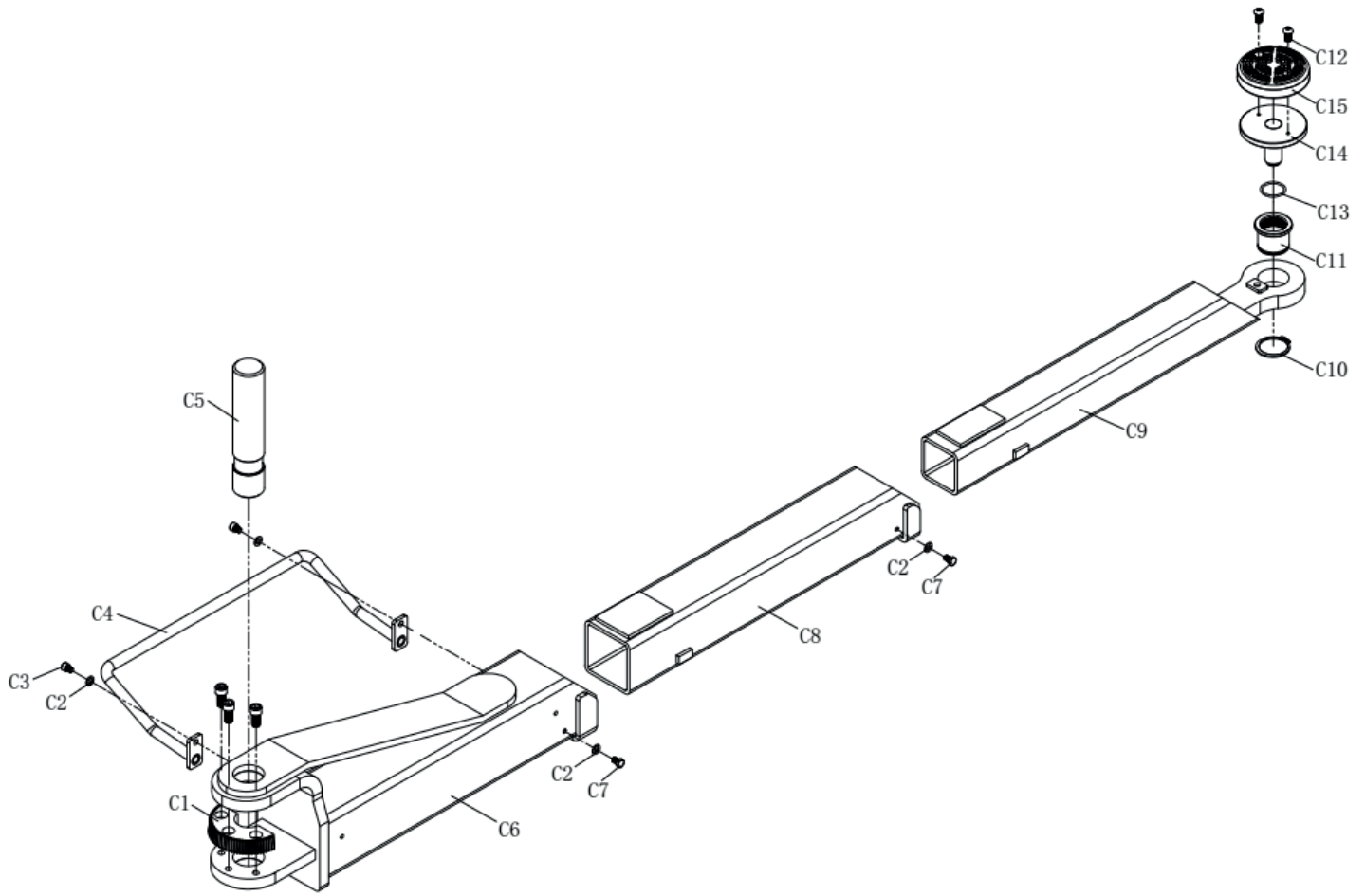

C1	lock tooth block(outer circle)
C2	plain washer Ø8
C3	hexagon socket head cap screw M8×12
C4	lifting arm guardrail assembly
C5	arm bolt
C6	outside lifting arm assembly
C7	hexagon head bolt full thread M8×12
C8	middle lifting arm assembly
C9	inside lifting arm assembly
C10	circlip for shaft Ø50
C11	support cushion screw seat
C12	hexagon socket button head screw M8×12
C13	steel cable circlip for shaft Ø32
C14	support cushion screw rod
C15	rubber mat

D
T50E/201809

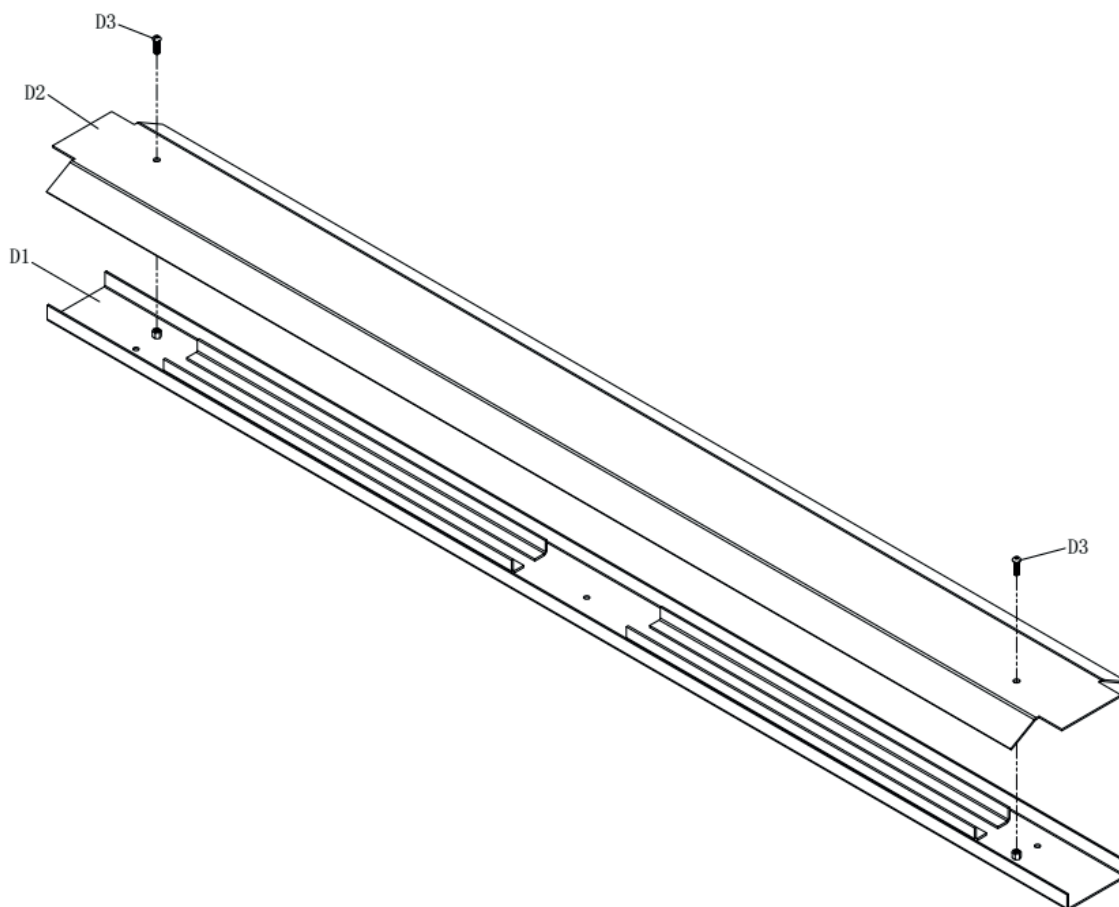

D1	oil hose slot board assembly
D2	oil hose cover
D3	hexagon socket button head screw M10×35

E
T50E/201809

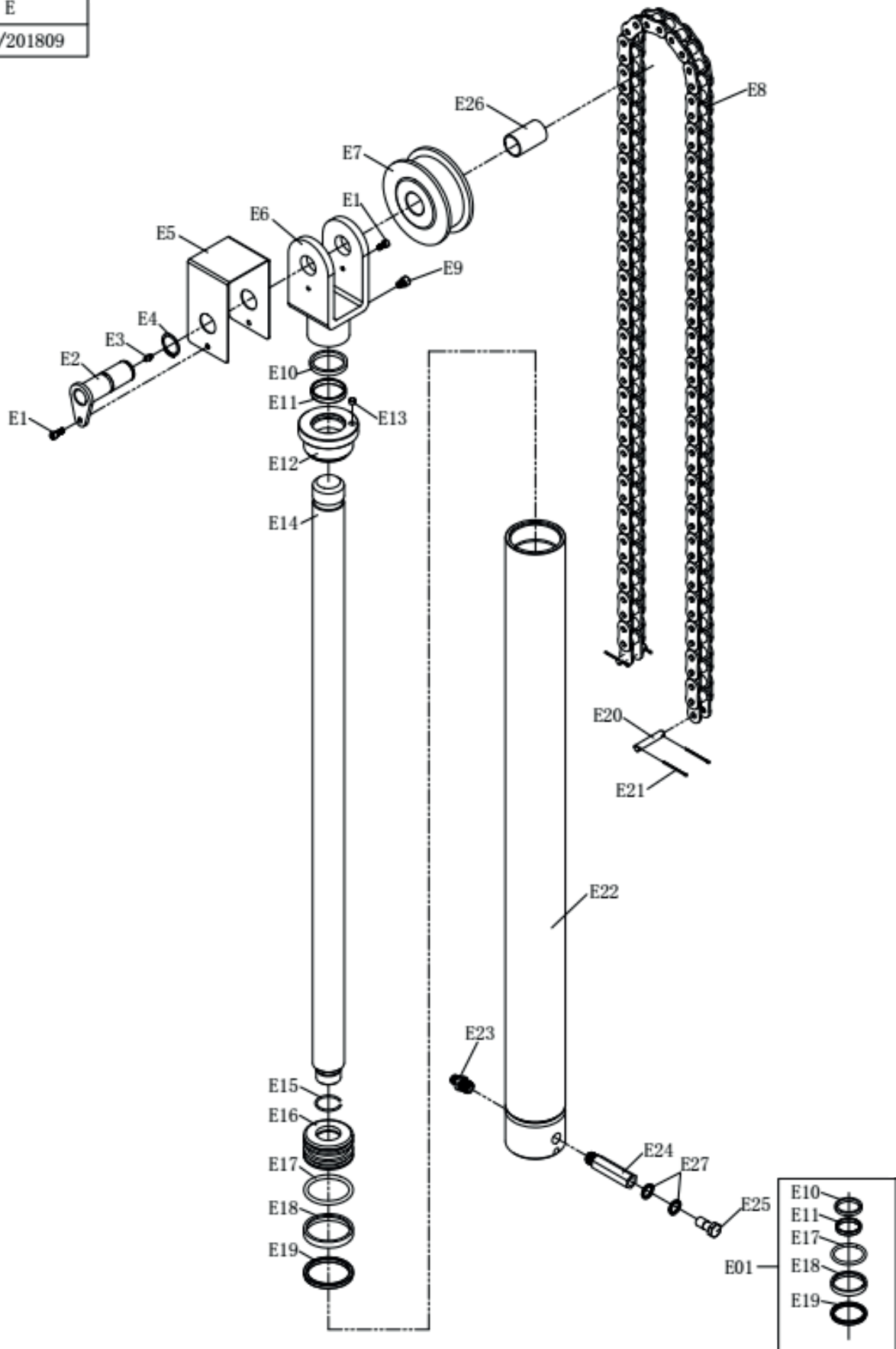

E1	hexagon socket head cap screw M6×16
E2	chain roller shaft assembly
E3	grease nipple
E4	circlip for shaft Ø30
E5	chain beffle
E6	chain roller support
E7	chain roller
E8	plate chain
E9	hexagon socket head cap screw M8×12
E10	dust-proof ring Ø45×53×6.5
E11	cylinder cover guide ring
E12	cylinder cover
E13	muffler
E14	piston rod
E15	steel cable circlip for hole Ø35
E16	piston
E17	piston O-ring 70×5.7
E18	guide ring
E19	UHS seal ring 60×70×6
E20	chain fixing shaft
E21	split pin Ø2.5×40
E22	main oil cylinder assembly
E23	oil hose straight joint
E24	cylinder one-way throttle valve long joint 75mm
E25	english hinged bolt G1/4
E26	shaft steel sleeve 343054
E27	combined sealing washer G1/4
E01	oil cylinder seal kit Ø70/Ø45

F

T50E/201809

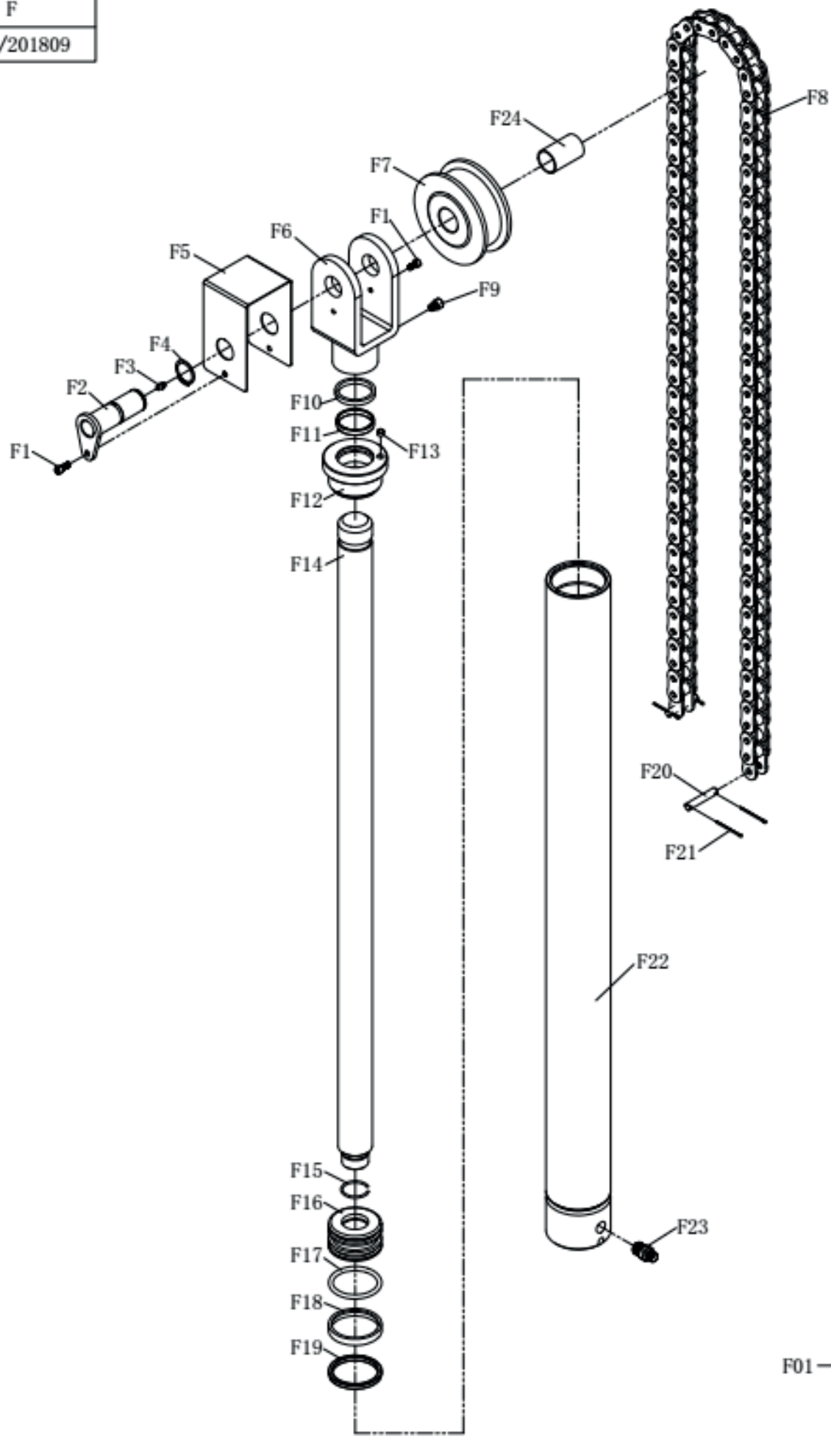

F1	hexagon socket head cap screw M6×16
F2	chain roller shaft assembly
F3	grease nipple
F4	circlip for shaft Ø30
F5	chain beffle
F6	chain roller support
F7	chain roller
F8	plate chain
F9	hexagon socket head cap screw M8×12
F10	dust-proof ring Ø45×53×6.5
F11	cylinder cover guide ring
F12	oil cylinder cover
F13	muffler
F14	piston rod
F15	steel cable circlip for hole Ø35
F16	piston
F17	piston O-ring 70×5.7
F18	guide ring
F19	UHS seal ring 60×70×6
F20	chain fixing shaft
F21	split pin
F22	sub oil cylinder assembly
F23	cylinder one-way throttle valve short joint
F24	shaft steel sleeve 343054
F01	oil cylinder seal kit

G
T50E/201809

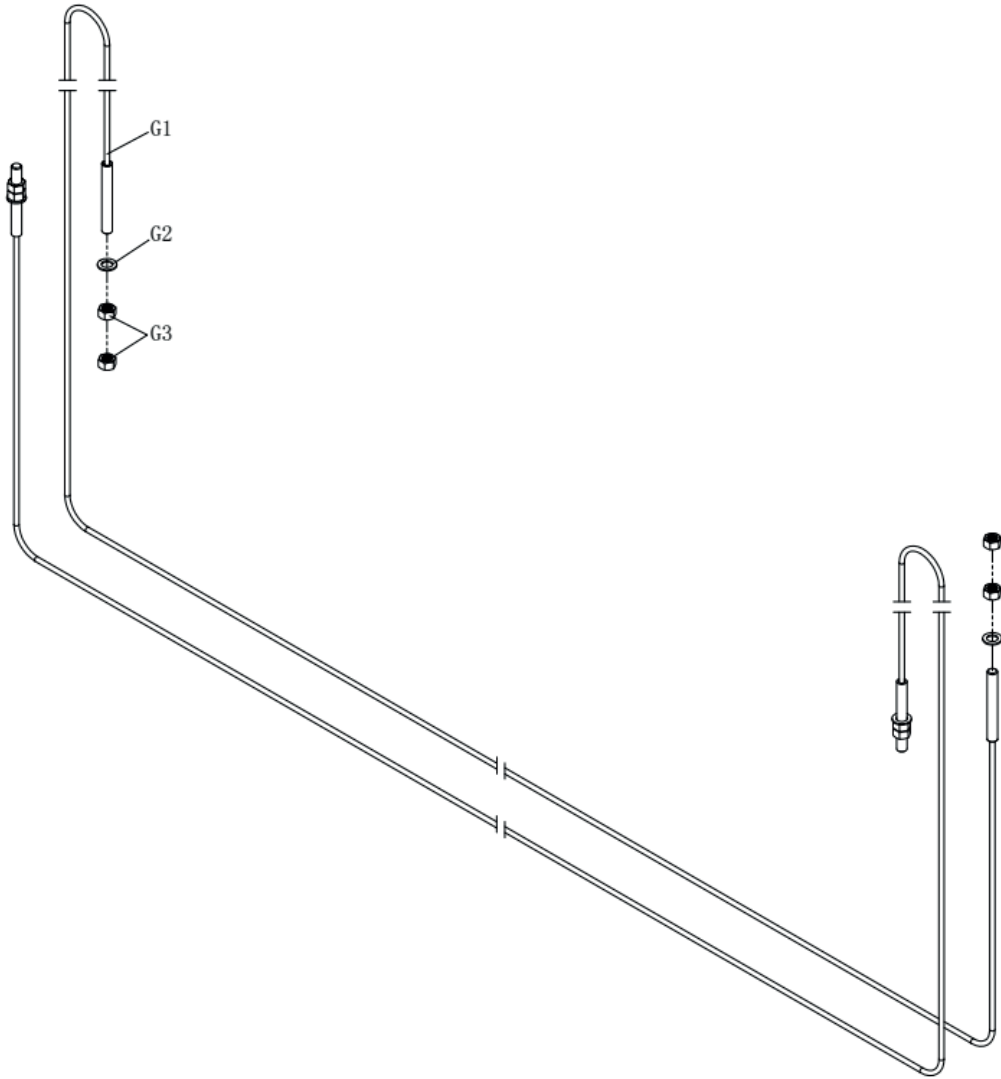

G1	steel cable assembly
G2	plain washer Ø20
G3	hexagon nut M20

H

T50E/201809

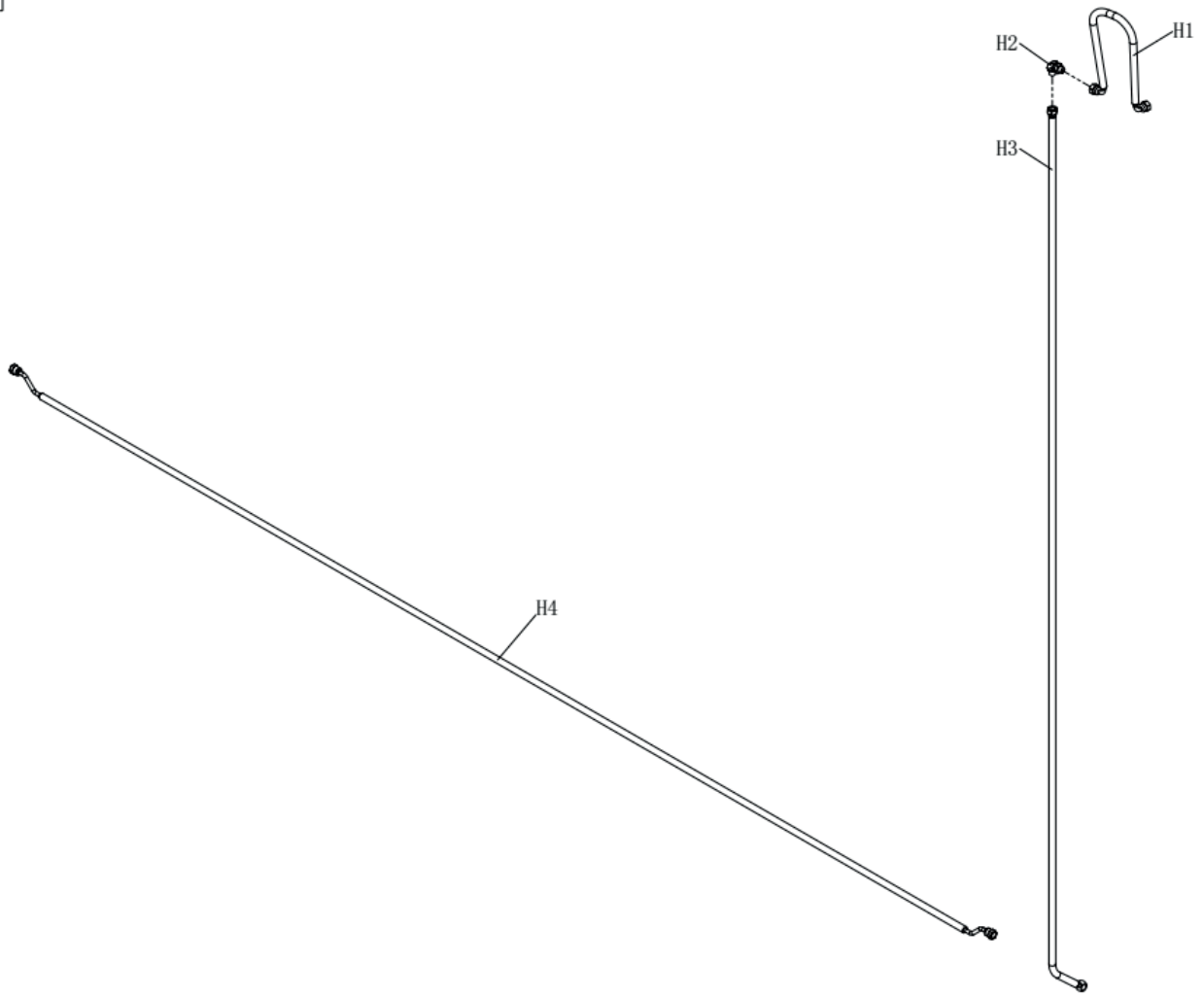

H1	high-pressure oil hose 300mm
H2	baffle elbow joint
H3	high-pressure oil hose 2390mm
H4	high-pressure oil hose 2840mm

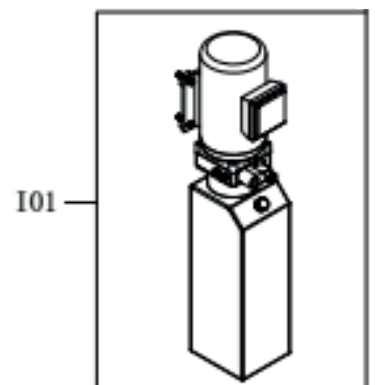
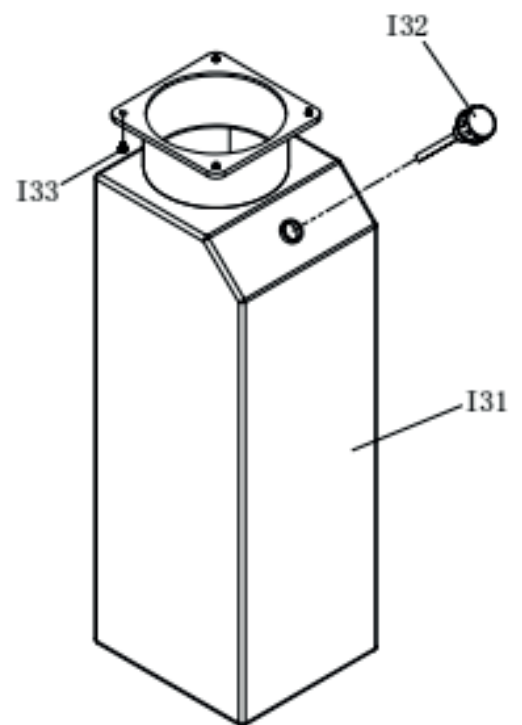
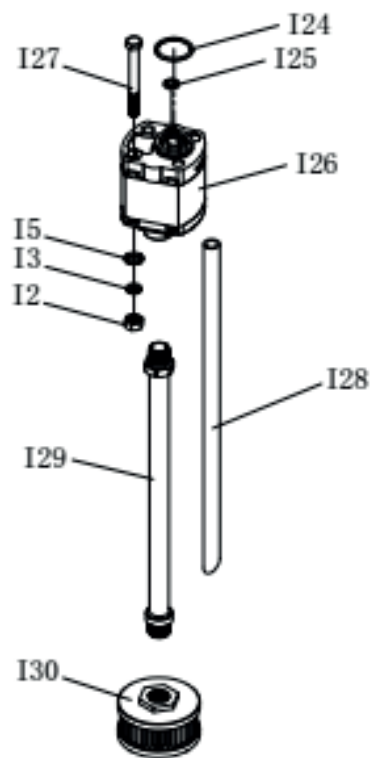
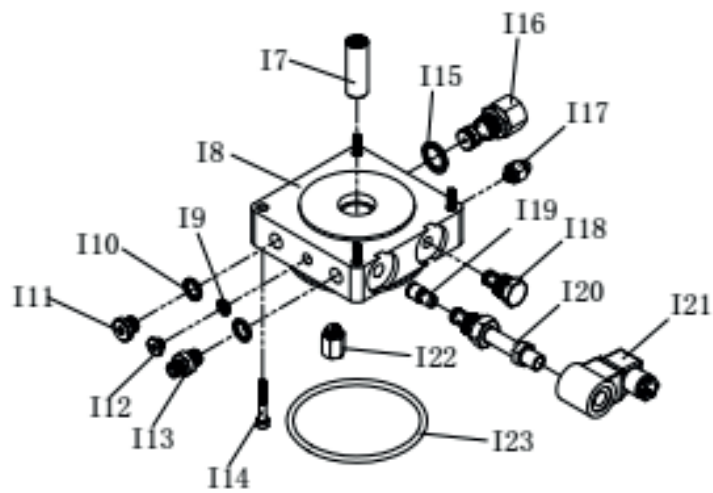
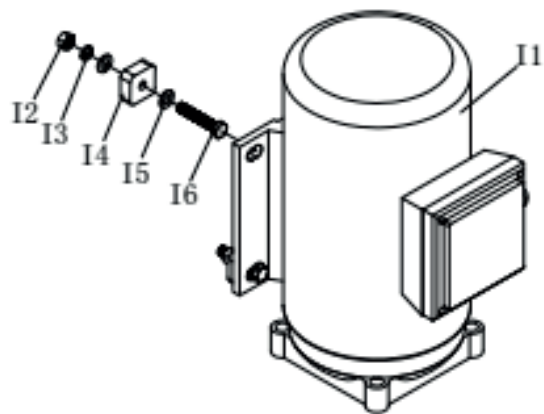

I1	3ph motor
I1(optional))	1ph motor
I2	hexagon nut M8
I3	spring washer Ø8
I4	motor cushion
I5	plain washer Ø8
I6	hexagon head bolt full thread M8×45
I7	coupling
I8	center valve socket
I9	combined sealing washer Ø8
I10	combined sealing washer Ø14
I11	plug
I12	plug
I13	oil hose straight joint
I14	hexagon socket head cap screw M6×40
I15	combined sealing washer Ø20
I16	overflow valve
I17	plug
I18	one-way valve
I19	balance valve
I20	normally closed solenoid valve spool
I21	normally closed solenoid valve coil
I22	cushion valve
I23	oil tank O-ring
I24	gear pump O-ring
I25	seal ring
I26	gear pump
I27	hexagon socket head cap screw M8×85
I28	return tube
I29	suction tube
I30	filter
I31	oil tank
I32	oil tank cap
I33	hexagon flange bolt M5×18
I01	power unit assembly 3kw/3ph/12l/3.2cc
I01 (optional)	power unit assembly 3kw/1ph/12l/2.7cc

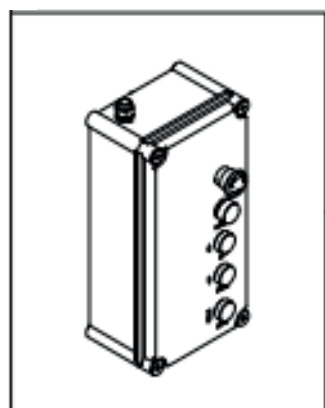
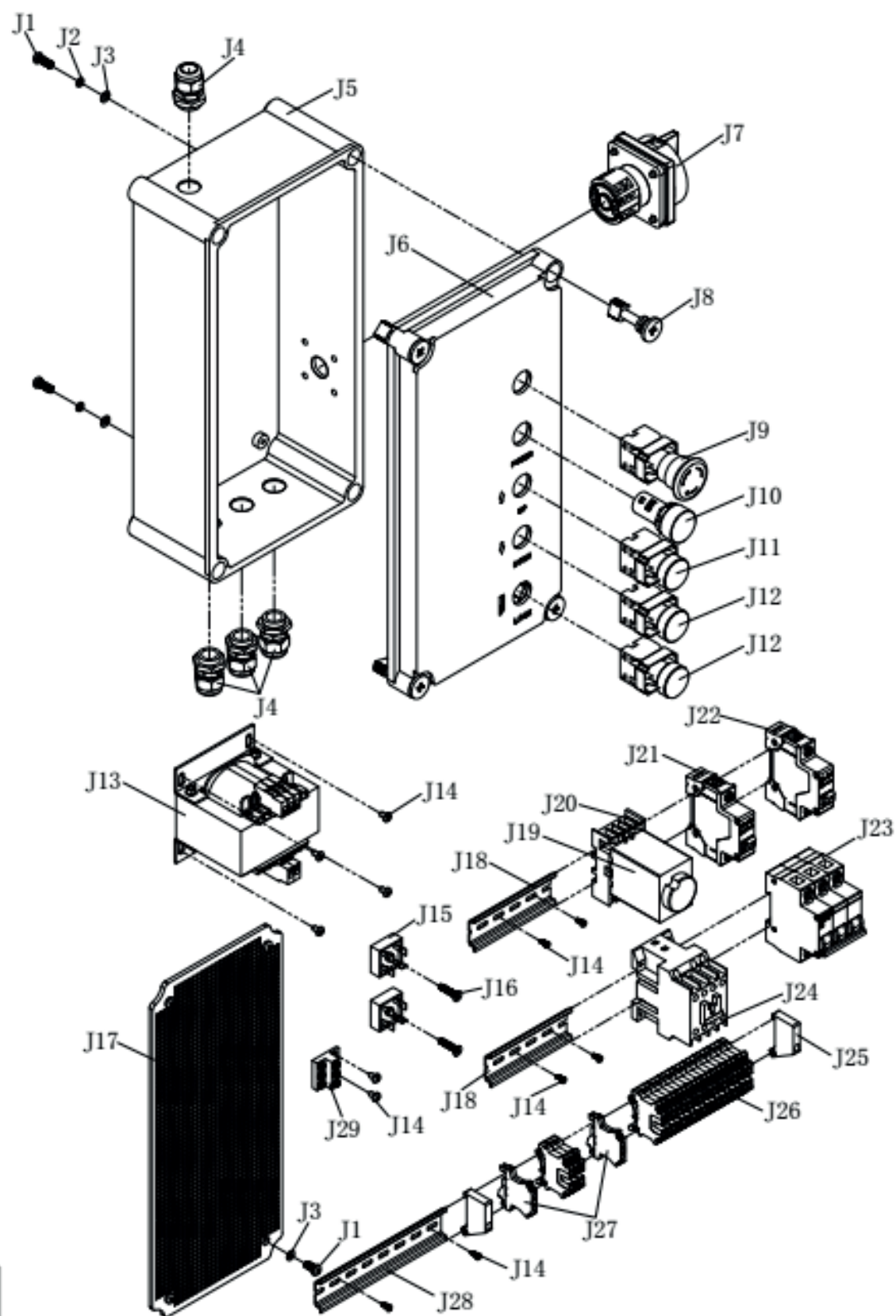

J01

J1	cross recessed pan head screw M5×12
J2	spring washer Ø5
J3	plain washer Ø5
J4	cable screw joint
J5	control box body
J6	control box cover
J7	power switch
J8	locking screw
J9	emergency stop switch
J10	signal
J11	button switch(1NO 1NC)
J12	button switch(2NO)
J13	transformer
J14	cross recessed pan head tapping screwST4.2×10 ST4.2×10
J15	rectifier bridge
J16	cross recessed pan head tapping screwST4.2×25 ST4.2×25ST4.2×25ST4.2×25ST4.2×25
J17	power panel
J18	lead rail
J19	time relay
J20	time relay socket
J21	circuit breaker
J22	circuit breaker
J23	circuit breaker
J24	AC contactor
J25	fixed terminal
J26	phoenix terminal
J27	earth terminal
J28	lead rail
J29	grounding strip
J01	electric control box