



S 116 BIKE

Esplso con elenco ricambi
Exploded view with spare parts list



Ed.09/14

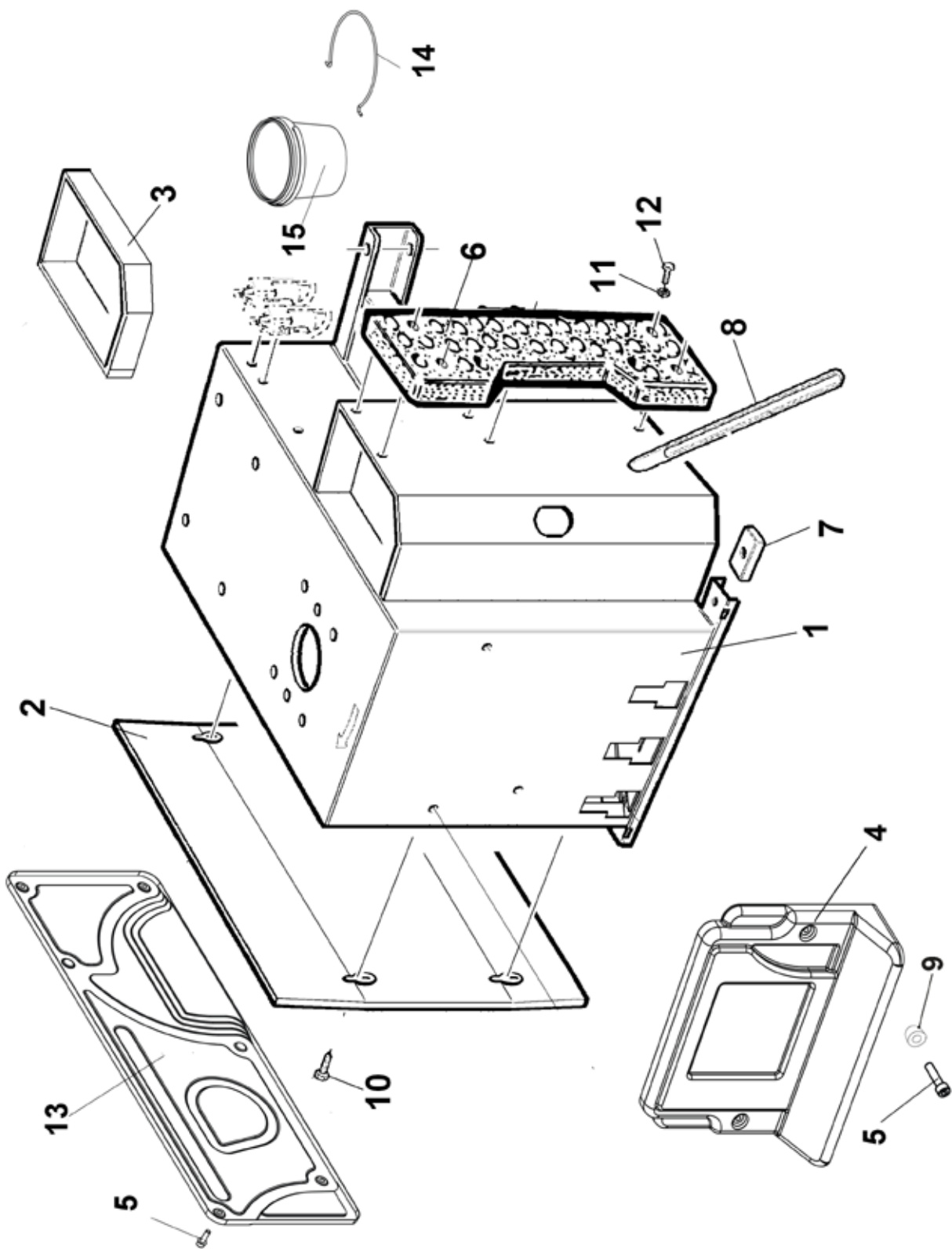

Rif. Ref.	Codice Code	Descrizione	Description
1	5835346	CARCASSA	SHELL
2	5835667	COPERCHIO LAT.	SIDE COVER
3	3035692	APPOGGIO TAMPONE ABS	TOP COVER ABS
4	3038046	PROTEZIONE PEDALI	PROTECTION PEDALES
5	4399890	VITE TCEI M 6x20	SCREW 6x20
6	3007064	APPOGGIO RUOTA	WHEEL SUPPORT
7	3002099	PIEDE IN PLASTICA PER CARCASSA	PLASTIC FOOT
8	3006970	LEVA ALZATALLONI TIPO C	BEAD LIFTING LEVER
9	3039217	TAPPO FISSAGGIO CARTER ABS	PLUG
10	4393749	VITE FLANG. TCEI 6X20 ZNT	VITE FLANG. TCEI 6X20 ZNT
11	4398848	RONDELLA 6 (6,6x18x1,5)/ZNT6593	WASHER 6 (6,6x18x1,5)
12	4399999	VITE TCEI M 6x25	SCREW 6x25
13	3037473	PANNELLO ABS SMONTAGOMME	ABS COVER
14	3000069	MOLLA ANELLO PER SECCHIELLO	SPRING
15	4293086	SECCHIELLO GRASSO	GREASE CUP

Per ordinazioni specificare **sempre** il **numero di matricola** rilevabile sull'apposita targhetta posta sulla macchina. Indicare **sempre** il numero di **riferimento** e il numero di **codice** del particolare.

When ordering **always** specify the **serial number** shown on the data plate placed on the machine. Please also **always** specify the **reference** and the **code** number of the spares you require.

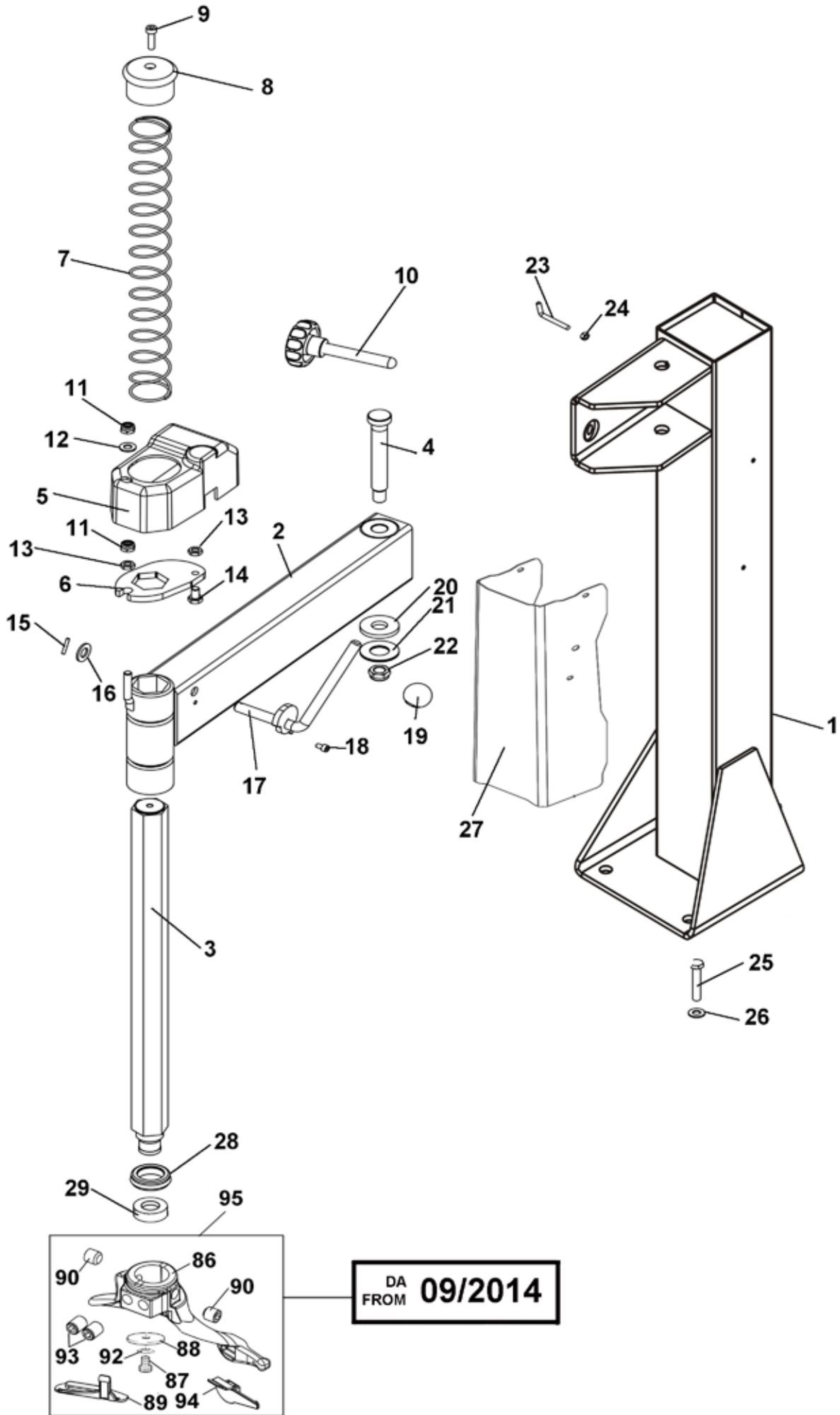

Rif. Ref.	Codice Code	Descrizione	Description
1	5835364	PALO VERTICALE	VERTICAL ARM
2	7007084	PALO ORIZZONTALE	HORIZONTAL ARM
3	3000049	BRACCIO OP.E.	HEXAGONAL ARM D.
4	3035362	PERNO FULCRO BRACCIO	TRUNNION
5	3033243	CARENATURA PALO ORIZ.	ARM FRAME
6	3000085	PIASTRA BLOC. BR.OP.-BRUN.	ARM LOCKING PLATE
7	3001672	MOLLA COMPR.BRACCIO OPER.-ZNT	SPRING
8	3000055	POMOLO BRACCIO OPERANTE	OPERATING ARM KNOB
9	4399134	VITE TCEI M 8x30	SCREW 8x30
10	3000487	VOLANTINO M16 L=130	HANDWHEEL
11	4399971	DADO AUTOBL.M10 BASSO	SELF-LOCKING NUT M10
12	4398633	RONDELLA 10 (10x18x2) ZNT 1750	WASHER D.10 (10x18x2)
13	4399967	DADO M10 6S BASSO	NUT M10
14	4398900	VITE OTTONE TE M10x25 5739	BRASS SCREW 10x25
15	4398783	SPINA ELASTICA D.4x24 6874	ELASTIC PIN D.4x24
16	4398807	RONDELLA 14 (15x28x2,5)ZNT6592	WASHER 14 (15x28x2,5)
17	2107085	LEVA BLOC.B.O. 110 -ZNT BIANCO	ARM LOCKING LEVER
18	4399964	VITE TCEI M 6x10	SCREW 6x10
19	4299952	POMOLO D.14	KNOB D.14
20	4397898	RASAMENTO ACCIAIO 25X50X0,5	STEEL SHIM 25x50x0,5
21	3007352	RONDELLA 20,5X50X6	WASHER 20,5x50x6
22	4399963	DADO AUTOBL.M16 BASSO	SELF-LOCKING NUT M16
23	3012978	GANCIO SUPP.PISTOLETTA	HOOK
24	4399889	DADO M6	NUT M6
25	4397894	VITE TE 16x60	SCREW 16x60
26	4399828	RONDELLA 16	WASHER D.16
27	3038558	LAMIERA PORTADESIVI	STICKERS PLATE
28	3017974	COPERCHIO ANELLO AMMORTIZ.	SHOCK ABSORB. RING COVER
29	3002601	AMMORTIZ. TORRETTA ES.41	MOUNTING TOOL SHOCK ABSORBER
86	3036626	UTENSILE INT. CORTO "LP"	SWINGING MOUNTING HEAD
87	4399953	VITE TE 10x16 8.8 5739	SCREW M10x16 8.8
88	4395804	RONDELLA DIN6319 "G" 14,2x35x5	WASHER DIN6319 "G" 14,2x35x5
89	3036650	INSERTO PLAST. X UT. CORTO	PLASTIC INSERT
90	4398179	VITE STEI 12x12 P.CONICA 5927	SCREW STEI M12x12
91	4399958	SPINA CIL.RETT. 5x24	PARALLEL PIN 5x24
92	4395805	RONDELLA DIN6319 "C" 10,2x21x4	WASHER DIN6319 "C" 10,2x21x4
93	4398426	VITE STEI 12x16 P.CONICA 5927	SCREW 12x16
94	3036922	INSERTO INFER. X UT. CORTO	PLASTIC INSERT
95	2038767	TORRETTA INTEGR.COMPLETA "LP"	MOUNTING TOOL

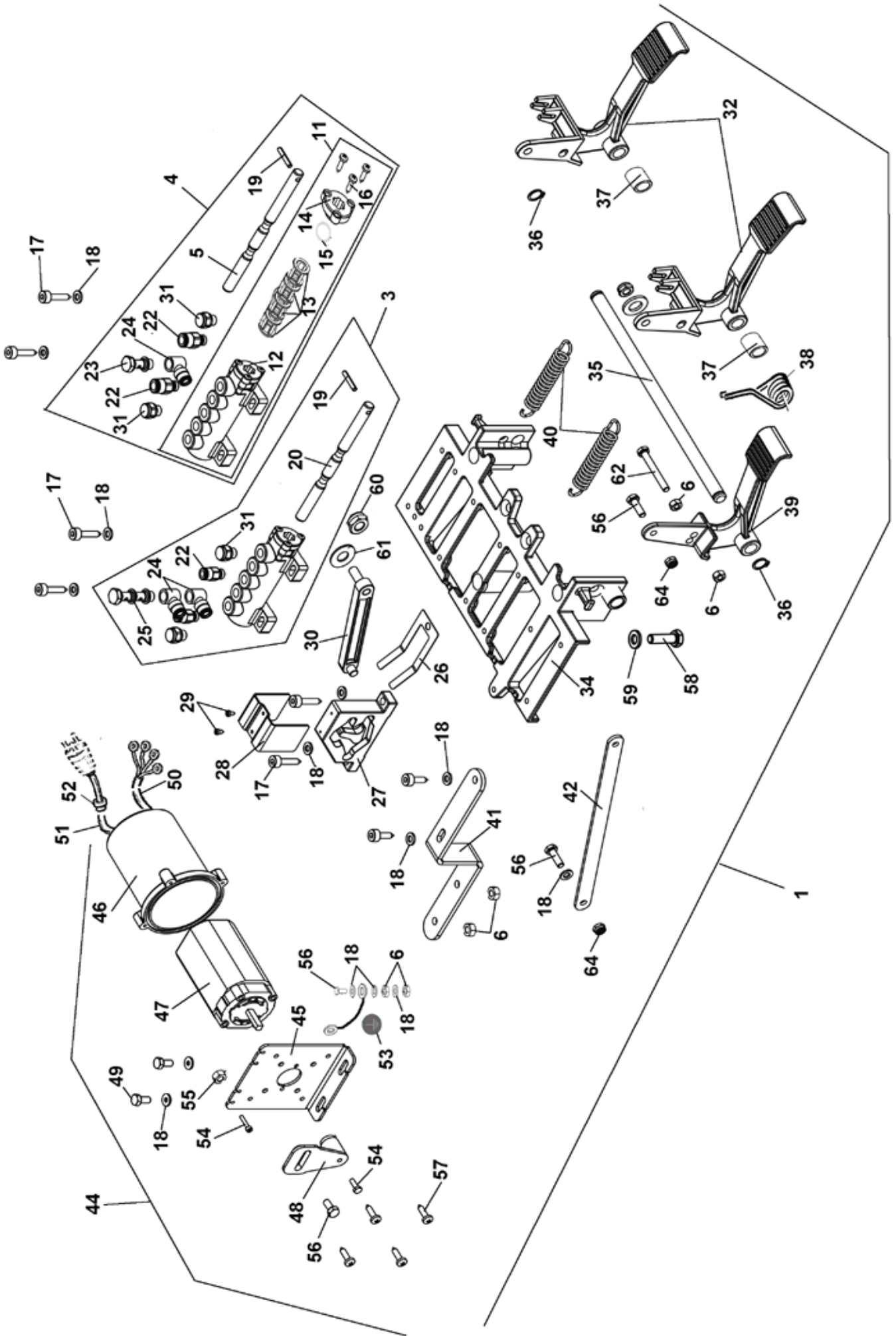

Rif. Ref.	Codice Code	Descrizione	Description
1	2035913	PEDALIERA	PEDAL CONTROL UNIT
3	2002529	GR.VALVOLA AUTOCENTRANTE	VALVE UNIT
4	2002528	GR.VALVOLA STALLONATORE D.E.	VALVE UNIT
5	3002443	PERNO VALVOLA STALLONATORE	BB D.E. VALVE ROD
6	4399889	DADO M 6 6S ZNT 5588	NUT M6
11	2002444	GR.VALVOLA LINEA SENZA PERNO	VALVE UNIT WITHOUT PIN
12	3001583	VALVOLA DISTRIB.-SENZA CHIAVET	DISTRIBUTION VALVE
13	3001584	DISTANZIALE X VALVOLA 3001583	SPACER FOR VALVE 3001583
14	3001585	FLANGIA X VALVOLA 3001583	BRIDE POUR SOUPEPE 3001583
15	4299000	ANELLO OR 9,8x3,85	JOINT OR 9,8x3,85
16	4399899	VITE AUTOF. TCIC 3,5x13 6954	SELF-TAPPING SCREW 3,5x13
17	4399274	VITE AUTOF. TCEI 5,5x26	SELF-TAPPING SCREW 5,5x26
18	4399998	RONDELLA 6 (6,4x12x1,6)ZNT6592	WASHER 6 (6,4x12x1,6)
19	4398783	SPINA ELASTICA D.4x24 6874	SPRING PIN D.4x24
20	3002442	PERNO X VALVOLA GRIFFE/RIBALT.	VALVE PIN
22	4198954	RACCORDO 6512 1/8"-8 S.R.	RAPIDE QUICK UNION 1/8"-8
23	4199929	RACCORDO 1631-01 1/8"	UNION 1/8"
24	4197819	RACCORDO 6610 1/8"" 8/6 S.RAP.	QUICK UNION 1/8" 8-6
25	4199928	RACCORDO 1631-02 1/8"	UNION 1/8"
26	4299911	BALESTRA A FORCELLA	FORKED LEAF SPRING
27	4299913	CAMMA DOPPIA	DOUBLE CAM
28	4299910	CAVALLOTTO GUIDA BIELLA	CONNECTING ROD GUIDE
29	4399891	VITE AUTOF.TC+ 2,9x6,5 ZNT	SELF-TAPPING SCREW 2,9x6,5
30	4299912	BIELLA PER CAMME	CONNECTING ROD
31	4193188	SILENZIATORE SPFL 1/8	SILENCER SPFL 1/8
32	3002159	PEDALE COM. AUTOC./STALL. ALL.	PEDAL
34	3002161	BASAMENTO PEDALIERA	PEDAL BOX BASE
35	3003095	PERNO ALLINEAMENTO PED. L.337	PEDALS ALINGMENT PIN L.337
36	4399864	ANELLO SEEGER E D.12 7435	SEEGER RING D.12
37	3007953	BOCCOLA D.18x12,5x21 PED.INV.	BUSH D.18x12,5x21
38	3017116	MOLLA COMANDO PEDALE	PEDAL CONTROL SPRING
39	3002157	PEDALE INVERT.	PEDAL
40	3018802	MOLLA RICH.PEDALE W.	PEDAL RETURN SPRING
41	3015342	STAFFA X SUPPORTO INVERT.	SUPPORT
42	3015341	BIELLA PER INVERTITORE	CONNECTING ROD
44	2015450	GR.INVERT. 3PH NEW 20A	REVERSE UNIT 3PH NEW 20A
44A	2015404	GR.INVERT. 1PH NEW 25A	REVERSE UNIT 1PH NEW 25A
45	3015340	SUPPORTO INVERTITORE	SUPPORT
46	3015345	PROTEZIONE X INVERT.	REVERSE COVER
47	4595380	INVERTIT. 25A SONTHEIMER	REVERSE 25A SONTHEIMER
48	3000175	LEVA INVERTITORE	REVERSE LEVER
49	4398723	VITE TE 6x12	SCREW 6x12
50	2001171	CAVO COLL.MOT.-INV. 3PH L=760	CONNECTING CABLE L=1500
51	2001512	CAVO ALIMENT. 3PH L=3110	FEEDING CABLE 3PH

Rif. Ref.	Codice Code	Descrizione	Description
52	4599986	BLOCCAPASSAC.RETT.D.9 SB7 R/3	CABLE HOLDER D.9
53	3005604	DECALCO BOLLINO PE 27552 BSO	STICKER
54	4399905	VITE TE 4x12 8.8 5739	SCREW M4x12 8.8
55	4396106	DADO M 4 6S ZNT 5588	NUT M4
56	4399892	VITE TE 6x20 8.8 ZNT 5739	SCREW 6x20
57	4397734	VITE TCIC M 2,9x12,7 8.8 5931	SCREW 2,9x12,7
58	4399946	VITE TE 8x16 8.8 ZNT 5739	SCREW 8x16
59	4399829	RONDELLA 8 (8,4x16x1,5)ZNT6592	WASHER 8 (8,4x16x1,5)
60	4399900	DADO AUTOBL.M 8 BASSO 6.S 7474	SELF-LOCKING NUT M8
61	4399894	MOLLA TAZZA 8,2X18X1 UNI 8737 -	BELLEVILLE WASHER 8,2x18x1
62	4397649	VITE TE 6x50 8.8 PF ZNT 5737	SCREW 6x50 8.8
64	4399893	DADO AUTOBL.M 6 BASSO.6S. 7474	SELF-LOCKING NUT M6
65	4399044	VITE TCEI M 3x12 12.9 5931	SCREW 3x12 12,9

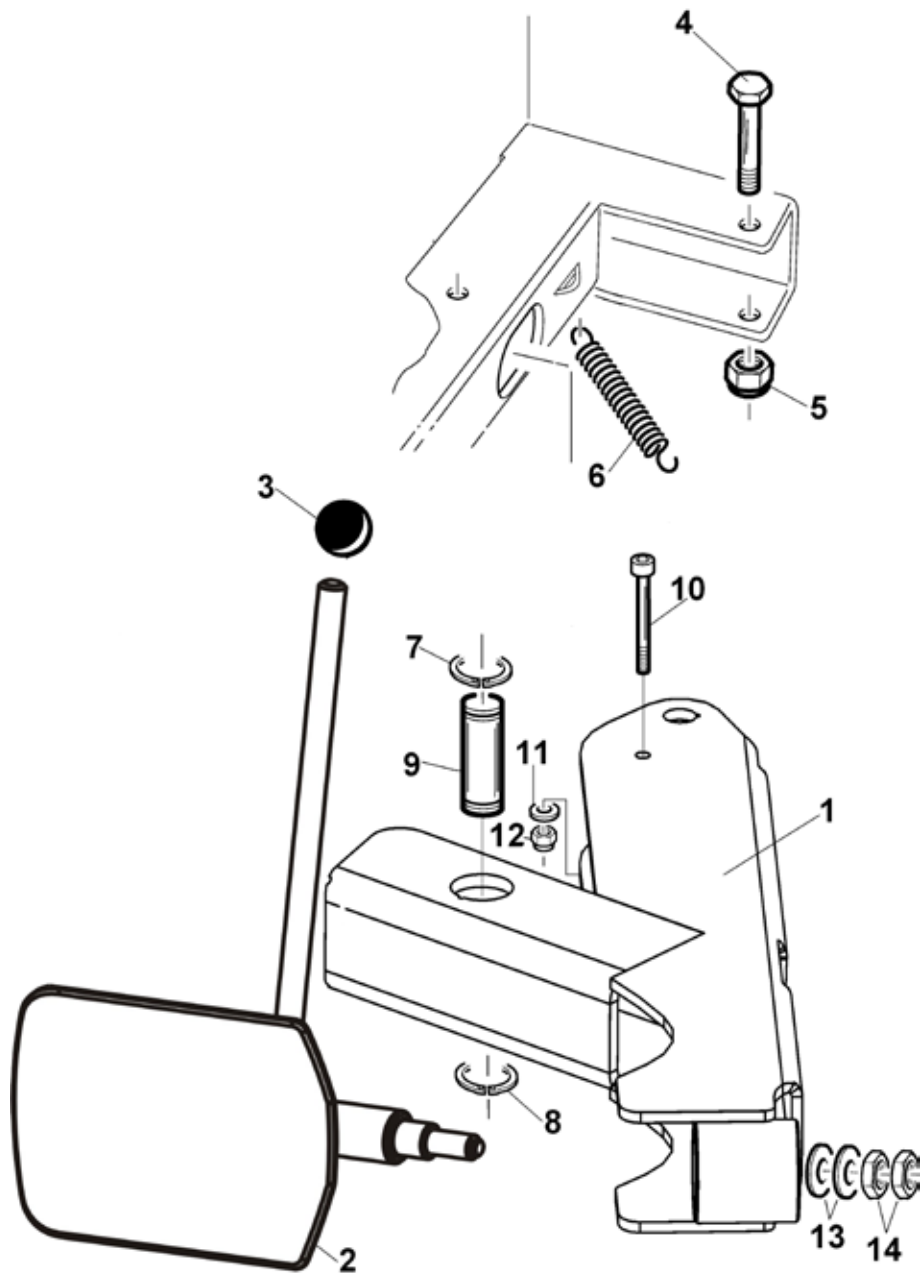

Rif. Ref.	Codice Code	Descrizione	Description
1	7035379	BRACCIO STALLONATORE	BEAD BREAKING ARM
2	7013331	PALETTA STALL.D.20/30 W320-ZNT	PALE DECOLLE-TALONS
3	4299952	POMOLO D.14	POMMEAU D.14
4	4399945	VITE TE 16x100 8.8 P.F. 5737	VIS TE 16x100
5	4399963	DADO AUTOBL.M16 BASSO.6S. 7474	ECROU DE VERROUILLAGE M16
6	3000114	MOLLA BRACCIO STALLONATORE	RESSORT BRAS DECOLLEUR
7	4399979	ANELLO SEEGER E D.30 7435	BAGUE SEEGER D.30
8	4399975	ANELLO SEEGER E D.20 7435	BAGUE SEEGER D.20
9	3007894	PERNO ORIENTABILE ASTA	PIVOT
10	4393072	VITE TCEI M 6x70	SCREW 6x70
11	4399998	RONDELLA 6 (6,4x12x1,6)ZNT6592	WASHER 6 (6,4x12x1,6)
12	4399893	DADO AUTOBL.M 6 BASSO	SELF-LOCKING NUT M6
13	4398899	MOLLA TAZZA 14,3x34x1,5	RESSORT BELLEVILLE 14,3x34x1,5
14	4396941	DADO M14 6S BASSO ZNT 5589	ECROU M14

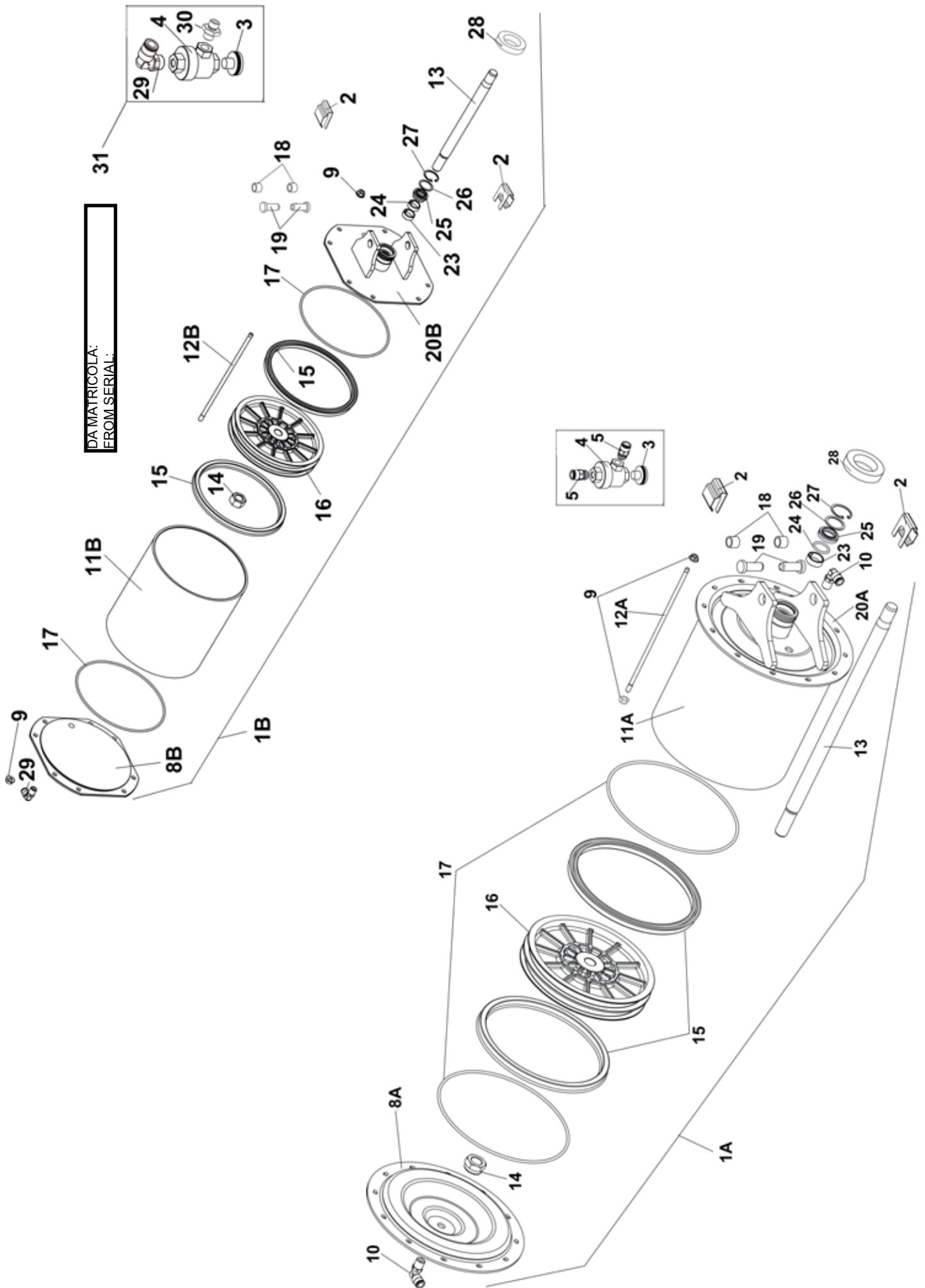

Rif. Ref.	Codice Code	Descrizione	Description
1A	2035725	GR.CILINDRO STALL. D. 200	BEAD BREAKER CYLINDER D.200
2	3009012	MOLLA A CLIPS	SPRING
3	4198808	SILENZIATORE 1/4" SPEC. D.24	SILENCER 1/4"
4	4199201	VALVOLA SCARICO RAPIDO DA 1/4"	QUICK RELIEF VALVE 1/4"
5	4198884	RACCORDO S6510 1/4"-8 S.R.	QUICK UNION 1/4"
8A	3035722	FLANGIA POSTERIORE CILINDRO	REAR FLANGE
9	4398007	DADO FLANGIATO M6 ZNT DIN 6923	FLANGED NUT M6
10	4198578	RACCORDO 6520 1/4"-8/6 GIREV.	ROTATING UNION 1/4" 8-6
11A	3035721	CAMICIA CILINDRO STALLONATORE	CYLINDER LINER
12A	3035723	TIRANTE CILINDRO STALL.	CYLINDER TIE ROD
13	3031738	ASTA CIL.STALL.S.E. D 200 (SHA)	CYLINDER SHAF
14	4394969	DADO M18x1,5 MEDIO 5588 ZNT	NUT M18x1.5
15	4193622	GUARNIZIONE 198X180X12	SEAL 198X180X12
16	3035724	PISTONE CILINDRO STALL.	CYLINDER PISTON
17	4293448	ANELLO OR 4750 D.190,1X3,53	O-RING D.190,1X3,53
18	3038052	BOCCOLA PER CILINDRO STALL.	DOUILLE
19	3009017	PERNO FULCRO CIL. STALL.	CYLINDER TRUNNION
20A	2135716	FLANGIA ANTERIORE CILINDRO	FRONT FLANGE
23	4298823	FASCIA DI GUIDA ASTA CILINDRO	NYLON GUIDE
24	4299168	ANELLO OR 3081 D.20,29x2,62	O-RING 20,29x2,62
25	3199601	ANELLO RASCH.BID.L7 NSW 20 30	SCRAPER
26	4398146	RASAMENTO 24x30x1	STEEL SHIM 24x30x1
27	3199599	ANELLO SEEGER I D.30 JV	SEEGER RING D.30
28	3031744	AMMORTIZZATORE D. 21X70X5	SHOCK-ABSORBER D.21X70X5

Rif. Ref.	Codice Code	Descrizione	Description
1B	2038743	GR.CILINDRO STALL. D. 200	BEAD BREAKER CYLINDER D.200
2	3009012	MOLLA A CLIPS	SPRING
3	4198808	SILENZIATORE 1/4" SPEC. D.24	SILENCER 1/4"
4	4199201	VALVOLA SCARICO RAPIDO DA 1/4"	QUICK RELIEF VALVE 1/4"
8B	3038694	FLANGIA POSTERIORE CILINDRO	REAR FLANGE
9	4398007	DADO FLANGIATO M6 ZNT DIN 6923	FLANGED NUT M6
11B	3038744	CAMICIA CILINDRO STALLONATORE	CYLINDER LINER
12B	3038746	TIRANTE CILINDRO STALL.	CYLINDER TIE ROD
13	3031738	ASTA CIL.STALL.S.E. D 200 (SHA)	CYLINDER SHAF
14	4394969	DADO M18x1,5 MEDIO 5588 ZNT	NUT M18x1.5
15	4193622	GUARNIZIONE 198X180X12	SEAL 198X180X12
16	3035724	PISTONE CILINDRO STALL.	CYLINDER PISTON
17	4293448	ANELLO OR 4750 D.190,1X3,53	O-RING D.190,1X3,53
18	3038052	BOCCOLA PER CILINDRO STALL.	DOUILLE
19	3009017	PERNO FULCRO CIL. STALL.	CYLINDER TRUNNION
20B	2138745	FLANGIA ANTERIORE CILINDRO	FRONT FLANGE
23	4298823	FASCIA DI GUIDA ASTA CILINDRO	NYLON GUIDE
24	4299168	ANELLO OR 3081 D.20,29x2,62	O-RING 20,29x2,62
25	3199601	ANELLO RASCH.BID.L7 NSW 20 30	SCRAPER
26	4398146	RASAMENTO 24x30x1	STEEL SHIM 24x30x1
27	3199599	ANELLO SEEGER I D.30 JV	SEEGER RING D.30
28	3031744	AMMORTIZZATORE D. 21X70X5	SHOCK-ABSORBER D.21X70X5
29	4192639	RACC. 6522 1/4"-8 (90° GIR) CORTO	UNION 1/4 SHORT THREAD
30	4199726	NIPPLIO 1/4" ART.2500	NIPPLE 1/4"
31	2039162	GR.VALVOLA SCARICO RAPIDO	VALVE GROUP

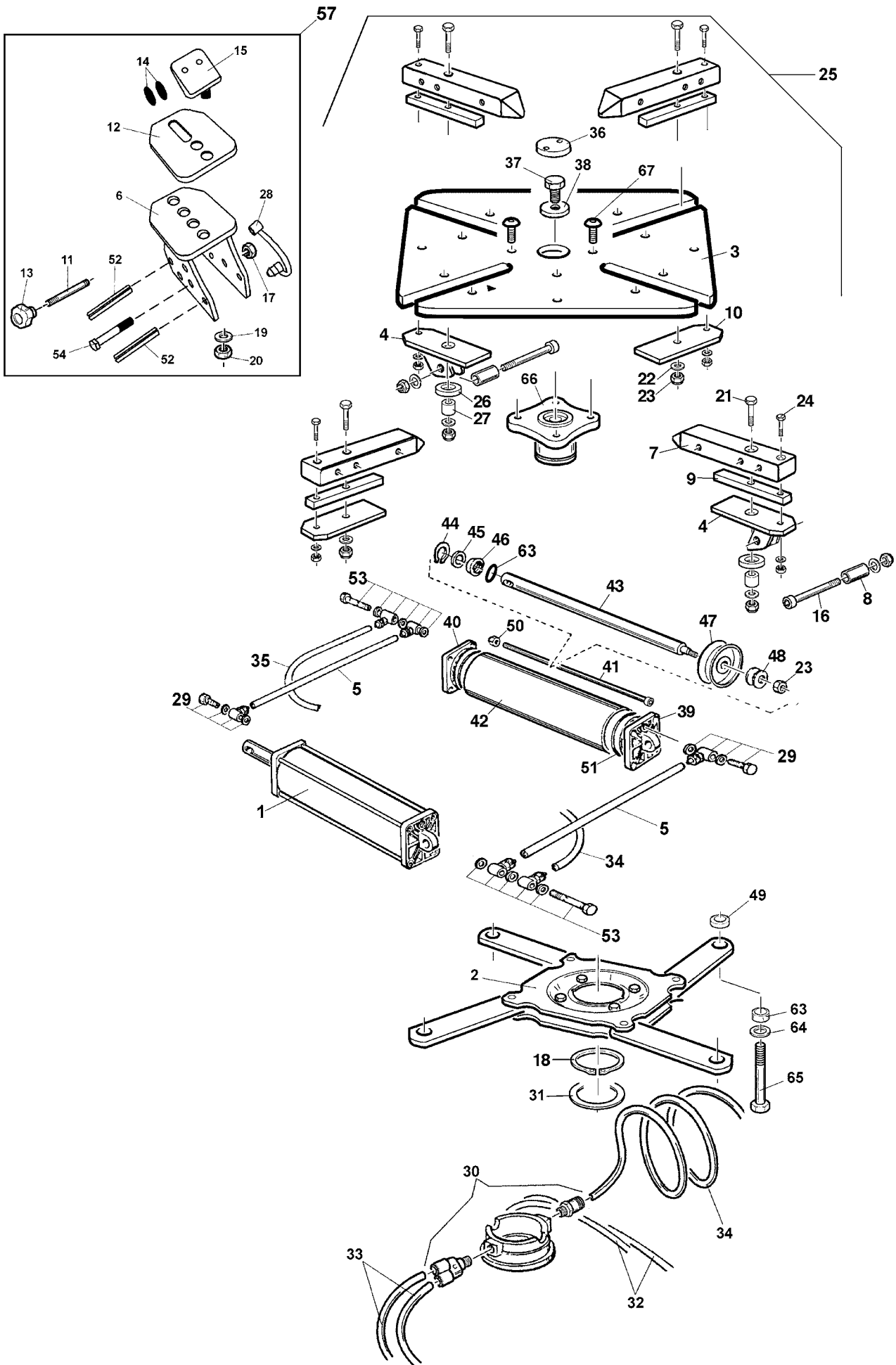

Rif. Ref.	Codice Code	Descrizione	Description
1	2008057	GR.CILINDRO AUT.17"1/2 INT.	17,5" TURNTABLE CYLINDER
2	2016087	FLANGIA X AUTOC.MOTO MOZZO ALL.	FLANGE
3	3016053	PIATTO AUTOC. 2C 17,5" (MOTO)	MOTORCYCLE TURNTABLE
4	2111216	ATTACCO CILINDRO MOTO-BRUNIT.	CYLINDER CONNECTION
5	3099338	TUBO ELASTOLAN D. 8X6 L=170	HOSE 8x6 L=170
6	2112659	ATTACCO RUOTE MOTO - ZNT. B.	MOTORCYCLE WHEELS CLAMP
7	3012698	SCORREVOLE R. MOTO-BRUNITO	SLIDE
8	3007864	DISTANZ. 12x18x45	SPACER 12x18x45
9	3008789	GUIDA SCORREV. MOTO	SLIDE GUIDE
10	3008792	PIATTO ATT.CIL. MOTO	CYLINDER CONNECTION PLATE
11	3008830	PERNO FIL. M8 L=80	PIN M8 L=80
12	3205070	PROT.PLASTICA ATT.R.MOTO	PLASTIC PROTECTION
13	4297465	POMELLO THB D.30 M8	THB KNOB D.30 M8
14	4299781	TASSELLO PER CUNEO	NYLON INSERT
15	4299782	CUNEO DI BLOCCAGGIO	WEDGE
16	4397501	VITE TCEI M12x90 8.8 5931	SCREW 12x90 8.8
17	4399900	DADO AUTOBL.M 8 BASSO	SELBSTSPERRENDE MUTTER M8
18	4395447	ANELLO SEEGER E D.85	SEEGER RING D.85
19	4399378	RONDELLA 10 (10,5x21x2)ZNT6592	WASHER D.10 (10,5x21x2)
20	4399967	DADO M10 6S BASSO ZNT 5589	NUT M10
21	4399422	VITE TCEI M12x65	SCREW 12x65
22	4399981	RONDELLA 12 (13x24x2,5)ZNT6592	WASHER 12 (13x24x2,5)
23	4399865	DADO AUTOBL.M12 BASSO.6S. 7474	SELF-LOCKING NUT M12
24	4396933	VITE TCEI M 8x45	SCREW 8x45
25	2016086	AUTOC. 2C 17,5" MOTO	TURNTABLE - 2 CYLINDERS
26	3000107	DISTANZIALE AUTOC.12,5X25X8	TURNTABLE SPACER 12,5x25x8
27	3000108	DISTANZIALE BIELLA D.12X18X11	CONNECT.ROD SPACER D.12x18x11
28	3010309	CAVETTO GOMMA X LEVA BLOCC.	RUBBER CABLE
29	4198898	RACCORDO SEMPLICE 1/8"-8-6	UNION 1/8" 8-6
30	4295067	RACCORDO GIREVOLE "Y"	ROTATING Y-UNION
31	3015864	ANELLO PER MOZZO	RING
32	3099335	TUBO ELASTOLAN D. 8X6 L=750	HOSE 8x6 L=750
33	3000870	TUBO ELASTOLAN D. 8X6 L=240	HOSE 8x6 L=240
34	3016820	SPIRALE RILSAN 8X6 L=560	RILSAN SPIRAL HOSE 8X6 L=560
35	2001948	TUBO CHIUS. AUTOCENTR. D.8	HOSE
36	3000062	PROTEZIONE CENTRALE PIATTO	TURNTABLE CAP
37	4395179	VITE TE 16x1,5x45 8.8	SCREW TE 16x1,5x45 8.8 5740
38	4395014	RONDELLA 17X30X3	WASHER 17X30X3
39	3002293	FLANGIA POSTER. CIL. AUT.	BACK FLANGE
40	3002294	FLANGIA ANTER. CIL. AUT.	FRONT FLANGE
41	3007947	VITE SPEC. TE M8x289,5 ZNT B.	SPECIAL SCREW M8x289,5
42	3008039	CAMICIA CIL. 17"1/2 L=265,5	CYLINDER LINER 17,5" L=265,5
43	3002290	ASTA CILINDRO AUT.17"1/2 L=316	17,5" TURNT. CYLIND. ROD L=316
44	3199599	ANELLO SEEGER I D.30 JV	SEEGER RING D.30
45	4398146	RASAMENTO D.24x30x0,3	SHIM D.24x30x0,3
46	3199601	RASCH.BID. NSW 20-30-6 XNU01	OIL SCRAPER
47	4198856	PISTONE MONOBLOCCO TDUOP D.75	PISTON D.75
48	4398753	RONDELLA 12,5x30x3 ZNT.	WASHER D.12,5x30x3
49	3006879	DISTANZIALE AUTOC. UNIF. 25x12x6,5	SPACER
50	4397678	DADO FLANGIATO M8 ZNT DIN 6923	FLANGE NUT M8
51	4298822	ANELLO OR 842 D.68,26x3,53	O-RING 842 D.68,26x3,53
52	4396615	SPINA ELASTICA	ELASTIC PIN D.8x50
53	4198870	RACCORDO DOPPIO 1/8"-8	DOUBLE UNION 1/8"-8
54	4396467	VITE TE 8x60 8.8	SCREW 8x60
57	2012706	GR.ATT.RUOTE BIKE (X ALU)	MOTORCYCLE ADAPTORS
63	3006880	DISTANZIALE BIELLA UNIF.12x18x9	SPACER
64	4398637	RONDELLA 12x21x2,5	WASHER D.12x21x2,5
65	4398838	VITE TE 12x1,25x45 8.8PF	SCREW 12x1,25x45
66	3015088	MOZZO AUTOC. 4C ALU	HUB
67	4395235	VITE TBEI 12x25 10.9	SCREW TBEI 12x25 10.9 UBK

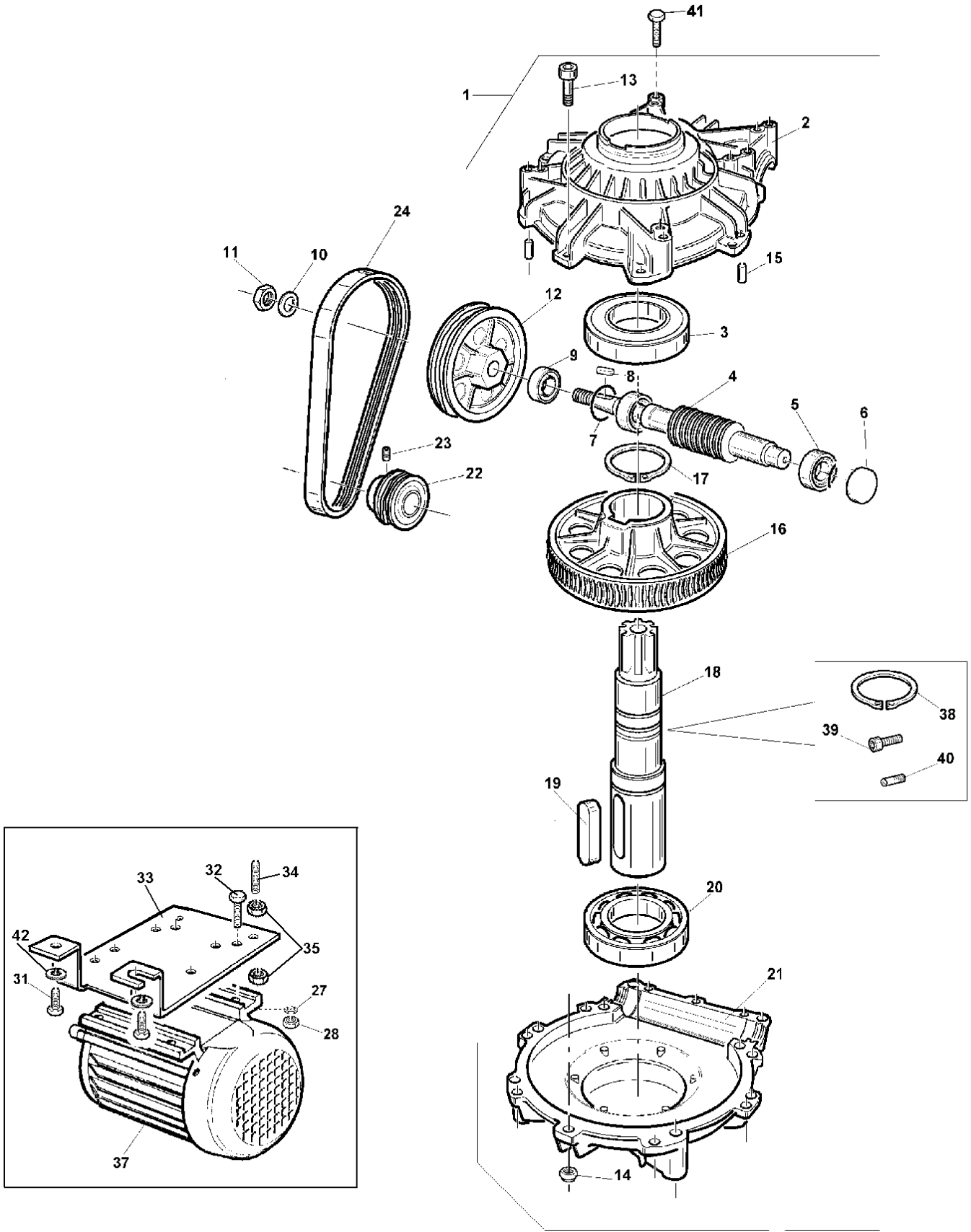

Rif. Ref.	Codice Code	Descrizione	Description
1	2010900	GR. RIDUTT. SMTG AUTO COMPL.	REDUCTION GEAR UNIT
2	3010872	SCATOLA SUPER. RIDUTT.	REDUCTION GEAR BOX
3	4296945	CUSCINETTO 6212 2RS 60x110x22	BEARING 60X110X22
4	3010883	VITE SENZA FINE RID.SMTG AUTO	WORM
5	4296944	CUSCINETTO RULLI CONICI 30204	BEARING
6	3017760	COPERCHIETTO TENUTA IN GOMMA	SEALING CAP
7	4294205	GUARNIZIONE FT D.40X35X4 NBR 75	SEAL D.40X35X4 NBR 75
8	4396947	LINGUETTA 6x6x18 (A) 6604	TAB 6X6X18
9	4296942	ANELLO TENUTA 20x35x10	O-RING 20X35X10
10	4398807	RONDELLA 14 (15x28x2,5)ZNT6592	WASHER 14 (15x28x2,5)
11	4396941	DADO M14 6S BASSO ZNT 5589	NUT M14
12	3010863	PULEGGIA RIDUTTORE	GEARBOX PULLEY
13	4399134	VITE TCEI M 8x30 8.8 5931	SCREW TCEI 8x30 8.8
14	4399900	DADO AUTOBL.M 8 BASSO 6.S 7474	SELF-LOCKING NUT M8
15	4396940	SPINA CIL.RETT. 8x20 6364A	PIN 8X20
16	3010884	RUOTA ELICOIDALE RID.-FINITA	HELICAL GEAR
17	4396946	ANELLO SEEGER E D.60x3 7436	SEEGER RING D.60X3
18	3010885	PERNO PER RUOTA ELICOID.	HELICAL GEAR STUD
19	4396948	LINGUETTA 16x10x70 (A) 6604	TAB 16X10X70
20	4296910	CUSCINETTO 6212 60x110x22	BEARING 60X110X22
21	3010873	SCATOLA INFERIORE RIDUTTORE	BOITE REDUCTEUR
22	3010864	PULEGGIA MOTORE	POULIE MOTEUR
23	4399922	VITE STEI 8x14 P.CIL. 5925	SCREW 8x14
24	4296813	CINGHIA PV 610 J6	BELT
27	4399829	RONDELLA 8 (8,4x16x1,5)ZNT6592	WASHER 8 (8,4x16x1,5)
28	4399976	DADO M 8 6S ZNT 5588	NUT M8
30	4398662	ROND.GROWER D.10 ZNT	GROWER WASHER D.10
31	4399966	VITE TE 10x20 8.8 5739	SCREW M10x20 - 8.8
32	4399935	VITE TE 8x25 8.8 5739	SCREW TE M8X25 8.8
33	3038015	SUPP. MOTORE	MOTOR SUPPORT
34	3031873	BARRA FILETTATA M10 L=65	THREADED BAR M10 L=65
37	4599924	MOTORE EL.3PH 230/400V 50Hz-SMTG T	MOTOR
37A	4595016	MOTORE 1PH HP1,2 240V.50Hz	1PH HP1,2 240V.50Hz MOTOR
38	4396700	ANELLO SEEGER E D.50x2 7436	SEEGER RING D.50x2
39	4399964	VITE TE M 6x10	SCREW TE M6 x 10
40	3001996	VITE PER RACCORDO GIREVOLE GT	SCREW FOR ROTATING UNION GT
41	4398664	VITE TE 10x70 8.8 PF ZNT 5737	SCREW TE M10x70
42	4398662	ROND.GROWER D.10 ZNT 1751	GROWER WASHER D.10

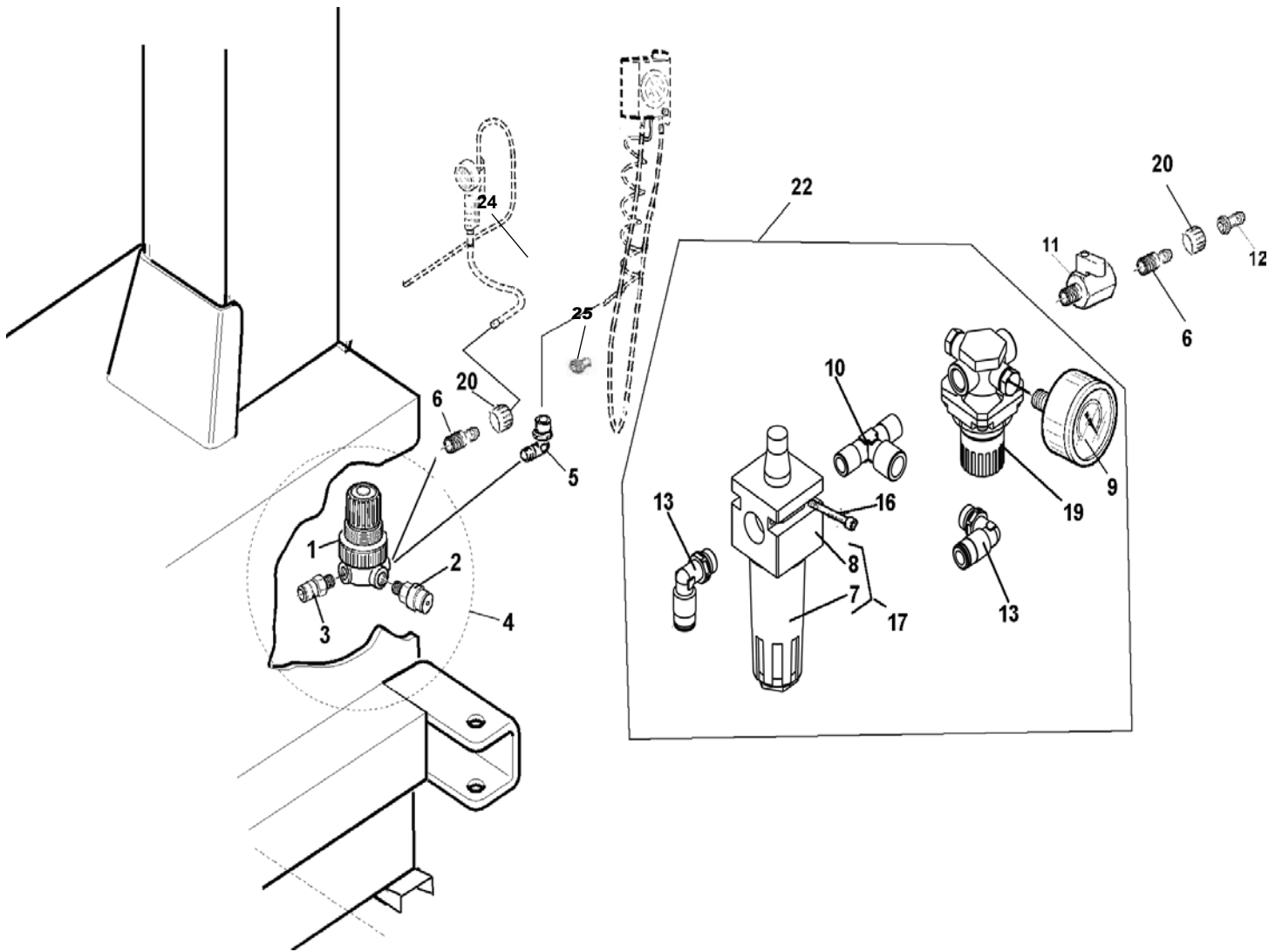

Rif. Ref.	Codice Code	Descrizione	Description
1	4198173	REGOLATORE 1/4" 0-3,5 BAR	REGULATOR 1/4" 0-3,5 BAR
2	4198435	VALV.SIC.1/8"0/4 BAR+RIV.+CAP.	SAFETY VALVE 1/8" 0/4 BAR
3	4198884	RACCORDO 6510 1/4"-8 S.RAPIDO	UNION 6510 1/4"
4	2010781	GR.REGOLAT.4 BAR USC. GT CE	4 BAR PRESSURE REGULATOR UNIT
5	4198578	RACCORDO 6520 1/4"-8/6 GIREV.	ROTATING UNION 1/4"-8/6
6	4199797	RACCORDO 9A/M 1/4"	UNION 9A/M 1/4"
7	4196316	TAZZA LUBRIFICATORE	LUBRICATOR CUP
8	4196315	CORPO LUBRIFICATORE	LUBRICATOR
9	4198071	MANOMETRO D.40 0-25BAR/PSI/KPA	MANOMETER
10	4198973	RACCORDO 2070 1/4" MFM	UNION
11	4196354	VALVOLA MVS 2901 DF 1/4"	VALVE MVS 2901 DF 1/4"
12	4199987	ATTACCO RESCA 2P 1/4 8	UNION 1/4
13	4198883	RACCORDO 6500 1/4"-8 S.RAPIDO	QUICK UNION 6500 1/4"-8
16	4396593	VITE TCEI M 4x40 8.8	SCHRAUBE 4x40
17	4193489	LUBRIFIC.1/4"	LUBRICATOR
19	4198951	REGOLATORE 1/4" 0,5-10 BAR	REGULATOR
20	4199077	DADO FRESATO 11A 1/4"	NUT 1/4"
22	2038751	GRUPPO LUBRIFICATORE + REGOLATORE	LUBRICATOR
25	3007754	TAPPO RACC.CON GHIERA	UNION + RING NUT



GIULIANO INDUSTRIAL S.p.a. - Via Guerrieri, 6 - 42015 Correggio (RE) ITALY