

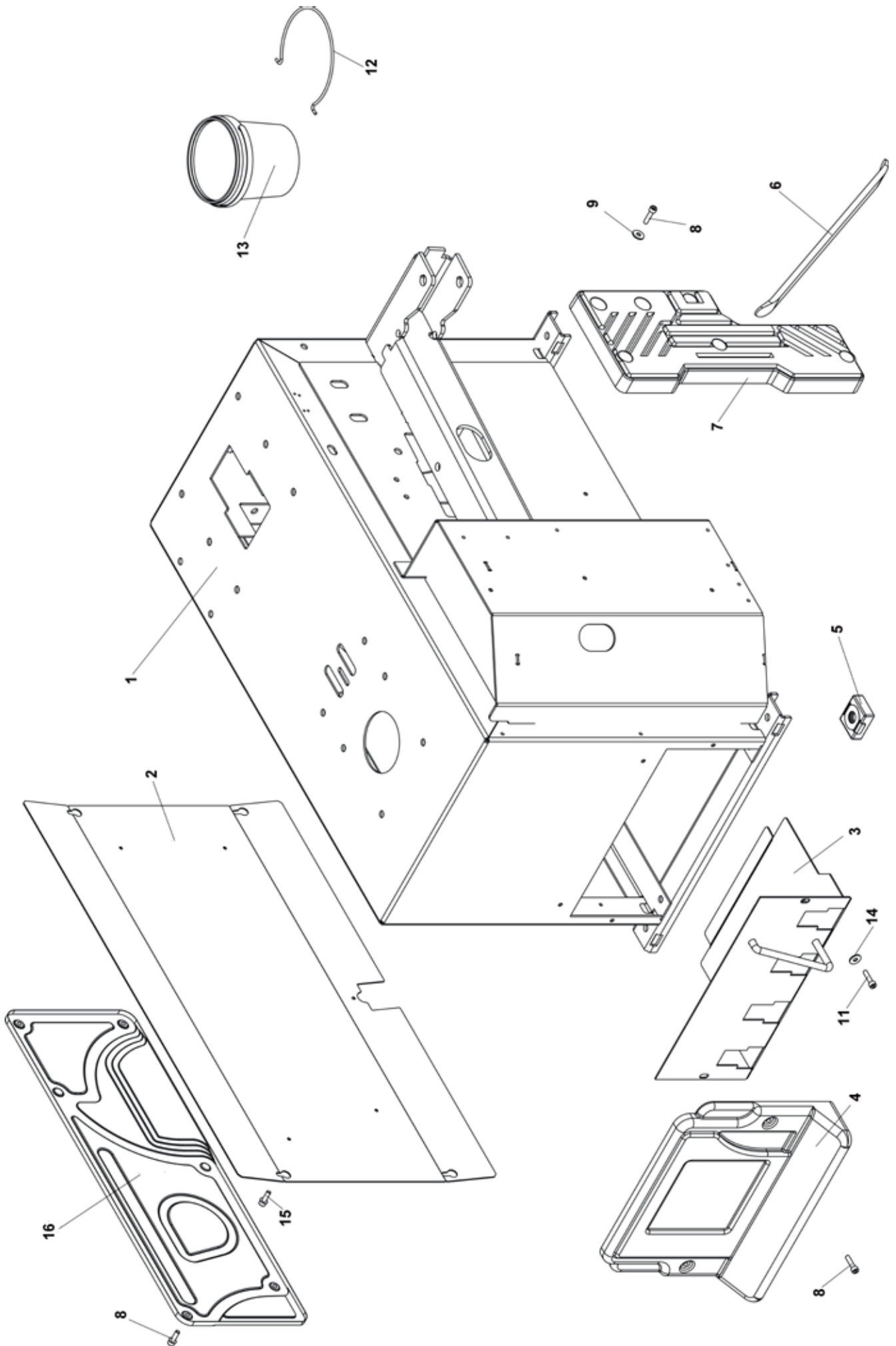

# S226

**Esplso con elenco ricambi**  
**Exploded view with spare parts list**





<b>Rif. Ref.</b>	<b>Codice Code</b>	<b>Descrizione</b>	<b>Description</b>
1	5837995	CARCASSA	SHELL
2	5835739	COPERCHIO LAT.	SIDE COVER
3	5833511	SUPP. PEDALIERA	SUPPORT PEDALES
4	3036046	PROTEZIONE PEDALI	PROTECTION PEDALES
5	3002099	PIEDE IN PLASTICA PER CARCASSA	PLASTIC FOOT
6	3006970	LEVA ALZATALLONI TIPO C	BEAD LIFTING LEVER
7	3032880	APPOGGIO RUOTA INTEGRALE	WHEEL SUPPORT
8	4399999	VITE TCEI M 6x25	SCREW 6x25
9	4398848	RONDELLA 6 (6,6x18x1,5)ZNT6593	WASHER 6
11	4398723	VITE TE 6x12 8.8	SCREW 6x12
12	3000069	MOLLA ANELLO PER SECCHIELLO	SPRING
13	4293086	SECCHIELLO GRASSO	GREASE CUP
14	4399998	RONDELLA 6 (6,4x12x1,6)	WASHER 6
15	4393749	VITE FLANG. TCEI 6X20 ZNT	SCREW 6x20
16	3037473	PANNELLO ABS SMONTAGOMME	ABS COVER

Per ordinazioni specificare **sempre** il **numero di matricola** rilevabile sull'apposita targhetta posta sulla macchina. Indicare **sempre** il numero di **riferimento** e il numero di **codice** del particolare.

When ordering **always** specify the **serial number** shown on the data plate placed on the machine. Please also **always** specify the **reference** and the **code** number of the spares you require.



<b>Rif. Ref.</b>	<b>Codice Code</b>	<b>Descrizione</b>	<b>Description</b>
1	2038649	PALO VERTICALE	VERTICAL ARM
2	2038650	PALO QUADRO COMPL. - NERO	HORIZONTAL ARM
3	3012323	BRACCIO OP.ES.41 L=719	BRAS
4	3031740	PIASTRA BLOCCAGGIO B.O.	ARM LOCKING PLATE
5	3035280	PIASTRA BLOCC.P.Q.	ARM LOCKING PLATE
6	3012357	PROTEZIONE ABS PALO QUADRO	ARM FRAME
7	3031813	PROTEZ.RIBALTAMENTO PALO	PROTECTION
8	3037483	LAMIERA PORTA-ADESIVI	INSIGNES DE PORTE EN ACIER
9	5837830	CASTELLO	TOWER
10	2002831	GR.CIL.RIBALT.EX BOLLINO ROSSO	TILTING CYLINDER
11	4198993	RACCORDO POC 1/8"-6 S.R.6510	QUICK UNION 1/8"
12	3008084	CAMICIA CIL.RIBALT. L=135	CYLINDER LINER
13	3015023	FLANGIA POSTER. CIL. AUT.	FLANGE
14	3015024	FLANGIA ANTER. CIL. AUT.	FLANGE
15	3002624	ASTA CILINDRO RIBALT. L=309	CYLINDER ROD
16	4298822	ANELLO OR 842 D.68,26x3,53	O-RING
17	4299168	ANELLO OR 3081 D.20,29x2,62	O-RING
18	3008085	VITE SPEC. TE M8x160 ZNT B.	SPECIAL SCREW M8x160
19	4397678	DADO FLANGIATO M8 ZNT DIN 6923	FLANGED NUT M8
20	3199601	RASCH.BID. NSW 20-30-6 XNU01	SCRAPER
21	4398146	RASAMENTO D.24x30x1	STEEL SHIM
22	3199599	ANELLO SEEGER I D.30 JV	SEEGER RING D.30
23	4198856	PISTONE MONOBLOCCO TDUOP	PISTON D.75
24	4398753	RONDELLA 12,5x30x3 ZNT.	WASHER
25	4399865	DADO AUTOBL.M12 BASSO.6S. 7474	SELF-LOCKING NUT M12
26	2008335	KIT RICAMBIO X COMANDO ROBOT	JEU REPLACEMENT COMMANDE
27	3012721	CAPPUCCIO ALLUM.	CAPUCHON
28	3035820	PERNO X CROC. M12 L=55 TCEI	PIN
29	4399981	RONDELLA 12 (13x24x2,5)ZNT6592	WASHER 12
30	3014633	DISTANZIALE PALO V.233	ARM SPACER
31	4398723	VITE TE 6x12 8.8 5739	SCREW 6x12
32	3031302	PERNO FULCRO PALO VERTICALE	AXE ARTICULATION
33	4399966	VITE TE 10x20 8.8	SCREW 10x20
34	3000495	RONDELLA D. 10x36x5	WASHER
35	3015750	BUSSOLA INTERNA -BRUNITO	INTERNAL WASHER
36	3015751	BUSSOLA ESTERNA AD ESPANS.	EXTERNAL WASHER
37	4399889	DADO M 6 6S	NUT M6
38	4392778	VITE STEI 8x20 P.P. 5923	SCREW 8x20
39	3038370	RULLO X TESTATA AUTOM.	ROLLER
40	3038371	SPINA CIL.RETT.	PIN
41	4197741	RACCORDO 6500 1/8"-4 90' A.107	UNION 1/8"
42	2099665	CILINDRO BLOCCAGGIO	LOCKING CYLINDER
43	4399827	VITE TE 8x20 8.8 5739	SCREW 8x20
44	4399947	RONDELLA 8 (9x32x4) ZNT 6593	RONDELLE 8 (9x32x4)
45	3000181	RONDELLA AMM. MOTORE	RONDELLE
46	4393989	VITE STEI 10x50 P.P. 5923	VIS 10X50
47	4399967	DADO M10 6S BASSO ZNT 5589	NUT M10
48	3015677	VITE SPECIALE M12X60	SCREW M12X60
49	4294966	MOLLA CARICO LEGG.	SPRING
50	4398805	DADO M12 ALTO ZNT 5587	NUT M12
51	3017517	GUIDA TUBI PALO QUADRO AUT. F/2	GUIDE
52	4393862	VITE STEI 10x40 P.P. 5923	SCREW 10X40
53	4299524	CAMICIA CILINDRO D.60	CYLINDER LINER D.60
54	4299522	ANELLO TENUTA DEP 60-50-5	SEALING RING
55	4399135	VITE TCEI M 6x35 8.8	SCREW 6x35
56	4197740	RACCORDO 6410 1/8"-4 S.RAPIDO	QUICK UNION 1/8"
57	4299523	PISTONE D.60	PISTON D.60
58	4399829	RONDELLA 8 (8,4x16x1,5)	WASHER 8 (8,4x16x1,5)
59	3007935	AMMORTIZZ. PALO QUADRO AUT.	SHOCK ABSORBER
60	3037779	RINFORZO FINE CORSA	RINFORCED LIMIT STOP
61	4399971	DADO AUTOBL.M10 BASSO	SELF-LOCKING NUT M10
62	4399133	VITE TCEI M 8x40 8.8 5931	SCREW 8x40
63	3005407	MOLLA COMPR.BO 41 MAXI-ZNT	SPRING
64	3001759	POMOLO BRACCIO OPERANTE	KNOB
65	4298812	ANELLO TENUTA SUR 8,4x16x6,2	SEALING RING 8,4x16x6,2
66	3002629	MOLLA COMPRES. 13,5x28 F 2,3	SPRING 13,5x28 F 2,3
67	4197718	RACCORDO 6520 M5-4 90' A.108	UNION
68	3002273	MOLLA A TRAZIONE—ZINC.	SPRING
69	4399896	VITE TE 4x35 8.8	SCREW 4x35
70	4399895	DADO AUTOBL.M 4 BASSO.6S	SELF-LOCKING NUT M4
71	3012459	BARRA FILETT. M10 L=120	THREADED BAR M10 L=120
72	3017974	COPERCHIO ANELLO AMMORTIZ.	SHOCK ABSORB. RING COVER
73	3002601	AMMORTIZ. TORRETTA ES.41	MOUNTING TOOL SHOCK ABSO
74	4398897	VITE TE 5x20	SCREW 5x20
75	4399292	RONDELLA 5 (5,3x10x1)	WASHER 5 (5,3x10x1)
76	4399892	VITE TE 6x20 8.8 5739	SCREW 6x20
77	3013355	INSERTO X MANIGLIA P.VALV.	HANDLE INSERT
78	2013172	GR.COMANDO BLOCC.	CONTROL
79	4197743	RACCORDO 6511 M5-4 DIR.	UNION
80	3038518	SUPPORTO GUIDA TUBI	GUIDE SUPPORT
81	4399133	VITE TCEI M 8x40 8.8 ZNT 5931	SCREW 8x40
82	4399900	DADO AUTOBL.M 8 BASSO 6.S 7474	SELF-LOCKING NUT M8
83	3038470	PIASTRINO FISSAGGIO TUBI ARIA T.	MOUNTING PLATE PIPE AIR H.
84	4399207	INGRASSATORE M6 (A)DRITTO	LUBRICATOR M6
85	3038782	FINECORSA PALO QUADRO	BACKSTOP
86	3015133	UTENSILE INTEGR.ORIENT. STRONG	SWINGING MOUNTING HEAD STRONG
87	4399953	VITE TE 10x16 8.8 5739	SCREW M10x16 8.8
88	4395804	RONDELLA DIN6319 "G" 14,2x35x5	WASHER DIN6319 "G" 14,2x35x5
89	3006689	INSERTO PLAST. X TORR. INTEGR.	PLASTIC INSERT
90	4398179	VITE STEI 12x12 P.CONICA 5927	SCREW STEI M12x12
92	4395805	RONDELLA DIN6319 "C" 10,2x21x4	WASHER DIN6319 "C" 10,2x21x4
93	4398426	VITE STEI 12x16 P.CONICA 5927	SCREW 12x16
94	3013650	INSERTO INFER. X TORR. INTEGR.	PLASTIC INSERT
95	2014250	TORRETTA INTEGR.OR.STRONG COMPL.	MOUNTING TOOL



<b>Rif. Ref.</b>	<b>Codice Code</b>	<b>Descrizione</b>	<b>Description</b>
1	2002449	PEDALIERA AUTOM.	PEDAL CONTROL UNIT
2	2002531	GR.VALVOLA RIBALT. LINEA	TILTING CONTROL VALVE
3	2002529	GR.VALVOLA AUTOCENTRANTE	VALVE UNIT
4	2002528	GR.VALVOLA STALLONATORE D.E.	VALVE UNIT
5	3002443	PERNO VALVOLA STALLONATORE	BB D.E. VALVE ROD
6	4399889	DADO M 6 6S ZNT 5588	NUT M6
11	2002444	GR.VALVOLA LINEA SENZA PERNO	VALVE UNIT WITHOUT PIN
12	3001583	VALVOLA DISTRIB.-SENZA CHIAVET	DISTRIBUTION VALVE
13	3001584	DISTANZIALE X VALVOLA 3001583	SPACER FOR VALVE 3001583
14	3001585	FLANGIA X VALVOLA 3001583	BRIDE POUR SOUPAPE 3001583
15	4299000	ANELLO OR 9,8x3,85	JOINT OR 9,8x3,85
16	4399899	VITE AUTOF. TCIC 3,5x13 6954	SELF-TAPPING SCREW 3,5x13
17	4398274	VITE AUTOF. TCEI 5,5x26	SELF-TAPPING SCREW 5,5x26
18	4399998	RONDELLA 6 (6,4x12x1,6)ZNT6592	WASHER 6 (6,4x12x1,6)
19	4398783	SPINA ELASTICA D.4x24 6874	SPRING PIN D.4x24
20	3002442	PERNO X VALVOLA GRIFFE/RIBALT.	VALVE PIN
21	4199843	REGOL.SCAR.SILENZ.SVE 1/8"	SILENCER OUTLET ADJUSTER
22	4199893	RACCORDO 6512 1/8"-6 S.R.	RAPIDE QUICK UNION 1/8"-6
23	4199927	RACCORDO 6610 1/8" 6/4 S.RAP.	UNION 1/8" -6
24	4197819	RACCORDO 6610 1/8" 8/6 S.RAP.	QUICK UNION 1/8" 8-6
25	4199928	RACCORDO 1631-02 1/8"	UNION 1/8"
26	4299911	BALESTRA A FORCELLA	FORKED LEAF SPRING
27	4299913	CAMMA DOPPIA	DOUBLE CAM
28	4299910	CAVALLOTTO GUIDA BIELLA	CONNECTING ROD GUIDE
29	4399891	VITE AUTOF.TC+ 2,9x6,5 ZNT	SELF-TAPPING SCREW 2,9x6,5
30	4299912	BIELLA PER CAMME	CONNECTING ROD
31	4193188	SILENZIATORE SPFL 1/8	SILENCER SPFL 1/8
32	3002159	PEDALE COM. AUTOC./STALL. ALL.	PEDAL
33	3002160	PEDALE COM. RIBALT. ALL.	TILTING CONTROL PEDAL
34	3002161	BASAMENTO PEDALIERA	PEDAL BOX BASE
35	3003095	PERNO ALLINEAMENTO PED. L.337	PEDALS ALIGNMENT PIN L.337
36	4399864	ANELLO SEEGER E D.12 7435	SEEGER RING D.12
37	3007953	BOCCOLA D.18x12,5x21 PED.INV.	BUSH D.18x12,5x21
38	3017116	MOLLA COMANDO PEDALE	PEDAL CONTROL SPRING
39	3002157	PEDALE INVERT.	PEDAL
40	3018802	MOLLA RICH.PEDALE W.	PEDAL RETURN SPRING
41	3015342	STAFFA X SUPPORTO INVERT.	SUPPORT
42	3015341	BIELLA PER INVERTITORE	CONNECTING ROD
44	2015450	GR.INVERT. 3PH NEW 20A	REVERSER UNIT 3PH NEW 20A
44A	2015404	GR.INVERT. 1PH NEW 25A	REVERSER UNIT 1PH NEW 25A
45	3015340	SUPPORTO INVERTITORE	SUPPORT
46	3015345	PROTEZIONE X INVERT.	REVERSER COVER
47	4595380	INVERTIT. 25A SONTHEIMER	REVERSER 25A SONTHEIMER
48	3000175	LEVA INVERTITORE	REVERSER LEVER
49	4398723	VITE TE 6x12	SCREW 6x12
50	2001171	CAVO COLL.MOT.-INV. 3PH L=760	CONNECTING CABLE L=1500
51	2001512	CAVO ALIMENT. 3PH L=3110	FEEDING CABLE 3PH

<b>Rif. Ref.</b>	<b>Codice Code</b>	<b>Descrizione</b>	<b>Description</b>
52	4599986	BLOCCAPASSAC.RETT.D.9 SB7 R/3	CABLE HOLDER D.9
53	3005604	DECALCO BOLLINO PE 27552 BSO	STICKER
54	4399905	VITE TE 4x12 8.8 5739	SCREW M4x12 8.8
55	4396106	DADO M 4 6S ZNT 5588	NUT M4
56	4399892	VITE TE 6x20 8.8 ZNT 5739	SCREW 6x20
57	4397734	VITE TCIC M 2,9x12,7 8.8 5931	SCREW 2,9x12,7
58	4399946	VITE TE 8x16 8.8 ZNT 5739	SCREW 8x16
59	4399829	RONDELLA 8 (8,4x16x1,5)ZNT6592	WASHER 8 (8,4x16x1,5)
60	4399900	DADO AUTOBL.M 8 BASSO 6.S 7474	SELF-LOCKING NUT M8
61	4399894	MOLLA TAZZA 8,2X18X1 UNI 8737 -	BELLEVILLE WASHER 8,2x18x1
62	4397649	VITE TE 6x50 8.8 PF ZNT 5737	SCREW 6x50 8.8
63	4398273	VITE AUTOF. TCEI 5,5x19 ZNT	SELF-TAPPING SCREW 5,5x19
64	4399893	DADO AUTOBL.M 6 BASSO.6S. 7474	SELF-LOCKING NUT M6
65	4399044	VITE TCEI M 3x12 12.9 5931	SCREW 3x12 12,9



**Pedaliere doppia velocità**

**Double speed pedal unit**

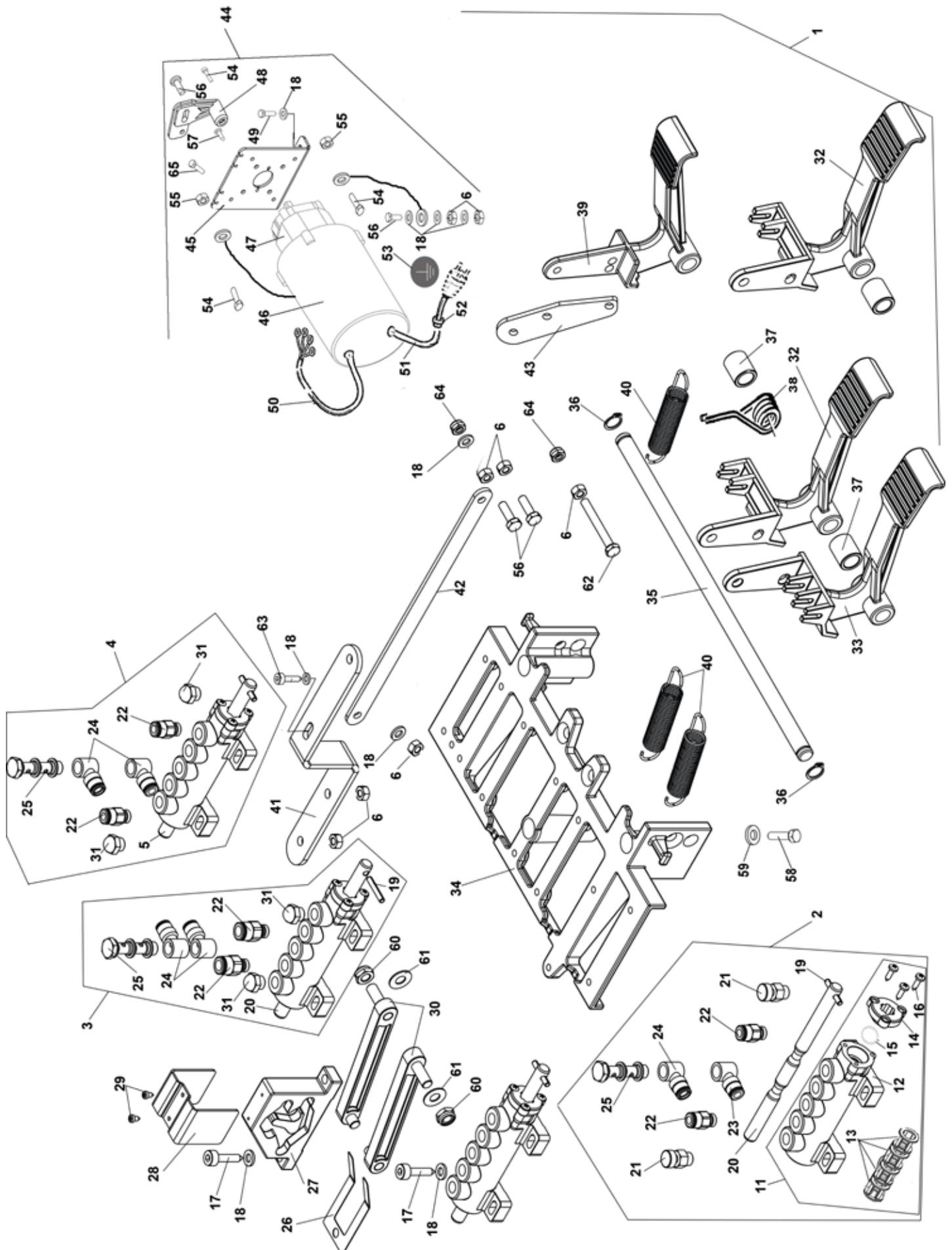



<b>Rif. Ref.</b>	<b>Codice Code</b>	<b>Descrizione</b>	<b>Description</b>
1	2010573	PEDALIERA AUTOM. D.E.	PEDAL CONTROL UNIT
2	2002531	GR.VALVOLA RIBALT. LINEA	TILTING CONTROL VALVE
3	2033238	GR.VALVOLA AUTOCENTRANTE	VALVE UNIT
4	2035178	GR.VALVOLA STALLONATORE D.E.	VALVE UNIT
5	3035999	PERNO VALVOLA STALLONATORE	BB D.E. VALVE ROD
6	4399889	DADO M 6 6S ZNT 5588	NUT M6
11	2002444	GR.VALVOLA LINEA SENZA PERNO	VALVE UNIT WITHOUT PIN
12	3001583	VALVOLA DISTRIB.-SENZA CHIAVET	DISTRIBUTION VALVE
13	3001584	DISTANZIALE X VALVOLA 3001583	SPACER FOR VALVE 3001583
14	3001585	FLANGIA X VALVOLA 3001583	BRIDE POUR SOUPAPE 3001583
15	4299000	ANELLO OR 9,8x3,85	JOINT OR 9,8x3,85
16	4399999	VITE AUTOF. TCIC 3,5x13 6954	SELF-TAPPING SCREW 3,5x13
17	4398274	VITE AUTOF. TCEI 5,5x26	SELF-TAPPING SCREW 5,5x26
18	4399998	RONDELLA 6 (6,4x12x1,6)ZNT6592	WASHER 6 (6,4x12x1,6)
19	4398783	SPINA ELASTICA D.4x24 6874	SPRING PIN D.4x24
20	3002442	PERNO X VALVOLA GRIFFE/RIBALT.	VALVE PIN
21	4199843	REGOL.SCAR.SILENZ.SVE 1/8"	SILENCER OUTLET ADJUSTER
22	4199893	RACCORDO 6512 1/8"-6 S.R.	RAPIDE QUICK UNION 1/8"-6
23	4199927	RACCORDO 6610 1/8" 6/4 S.RAP.	UNION 1/8" -6
24	4197819	RACCORDO 6610 1/8" 8/6 S.RAP.	QUICK UNION 1/8" 8-6
25	4199928	RACCORDO 1631-02 1/8"	UNION 1/8"
26	4299911	BALESTRA A FORCELLA	FORKED LEAF SPRING
27	4299913	CAMMA DOPPIA	DOUBLE CAM
28	4299910	CAVALLOTTO GUIDA BIELLA	CONNECTING ROD GUIDE
29	4399891	VITE AUTOF.TC+ 2,9x6,5 ZNT	SELF-TAPPING SCREW 2,9x6,5
30	4299912	BIELLA PER CAMME	CONNECTING ROD
31	4193188	SILENZIATORE SPFL 1/8	SILENCER SPFL 1/8
32	3002159	PEDALE COM. AUTOC./STALL. ALL.	PEDAL
33	3002160	PEDALE COM. RIBALT. ALL.	TILTING CONTROL PEDAL
34	3002161	BASAMENTO PEDALIERA	PEDAL BOX BASE
35	3003095	PERNO ALLINEAMENTO PED. L.337	PEDALS ALIGNMENT PIN L.337
36	4399864	ANELLO SEEGER E D.12 7435	SEEGER RING D.12
37	3007953	BOCCOLA D.18x12,5x21 PED.INV.	BUSH D.18x12,5x21
38	3017116	MOLLA COMANDO PEDALE	PEDAL CONTROL SPRING
39	3002157	PEDALE INVERT.	PEDAL
40	3018802	MOLLA RICH.PEDALE W.	PEDAL RETURN SPRING
41	3015342	STAFFA X SUPPORTO INVERT.	SUPPORT
42	3015341	BIELLA PER INVERTITORE	CONNECTING ROD
43	3011481	PROL. PEDALE INV	PEDAL EXTENSION
44	2034034	GR.INVERT. 3PH 2V NEW 20A	REVERSER UNIT 3PH 2V NEW
45	3015340	SUPPORTO INVERTITORE	SUPPORT
46	3015599	PROTEZIONE X INVERT.	REVERSER COVER
47	4595330	INVERTIT. 25A SONTHEIMER 2V	REVERSER 25A SONTHEIMER 2V
48	3011323	LEVA INVERTITORE	REVERSER LEVER
49	4398723	VITE TE 6x12	SCREW 6x12
50	2001171	CAVO COLL.MOT.-INV. 3PH L=760	CONNECTING CABLE L=1500
51	2001512	CAVO ALIMENT. 3PH L=3110	FEEDING CABLE 3PH

<b>Rif. Ref.</b>	<b>Codice Code</b>	<b>Descrizione</b>	<b>Description</b>
52	4599986	BLOCCAPASSAC.RETT.D.9 SB7 R/3	CABLE HOLDER D.9
53	3005604	DECALCO BOLLINO PE 27552 BSO	STICKER
54	4399905	VITE TE 4x12 8.8 5739	SCREW M4x12 8.8
55	4396106	DADO M 4 6S ZNT 5588	NUT M4
56	4399892	VITE TE 6x20 8.8 ZNT 5739	SCREW 6x20
57	4397734	VITE TCIC M 2,9x12,7 8.8 5931	SCREW 2,9x12,7
58	4399946	VITE TE 8x16 8.8 ZNT 5739	SCREW 8x16
59	4399829	RONDELLA 8 (8,4x16x1,5)ZNT6592	WASHER 8 (8,4x16x1,5)
60	4399900	DADO AUTOBL.M 8 BASSO 6.S 7474	SELF-LOCKING NUT M8
61	4399894	MOLLA TAZZA 8,2X18X1 UNI 8737 -	BELLEVILLE WASHER 8,2x18x1
62	4397649	VITE TE 6x50 8.8 PF ZNT 5737	SCREW 6x50 8.8
63	4398273	VITE AUTOF. TCEI 5,5x19 ZNT	SELF-TAPPING SCREW 5,5x19
64	4399893	DADO AUTOBL.M 6 BASSO.6S. 7474	SELF-LOCKING NUT M6
65	4399044	VITE TCEI M 3x12 12.9 5931	SCREW 3x12 12,9

**Pedaliara inverter**

**Inverter pedal unit**

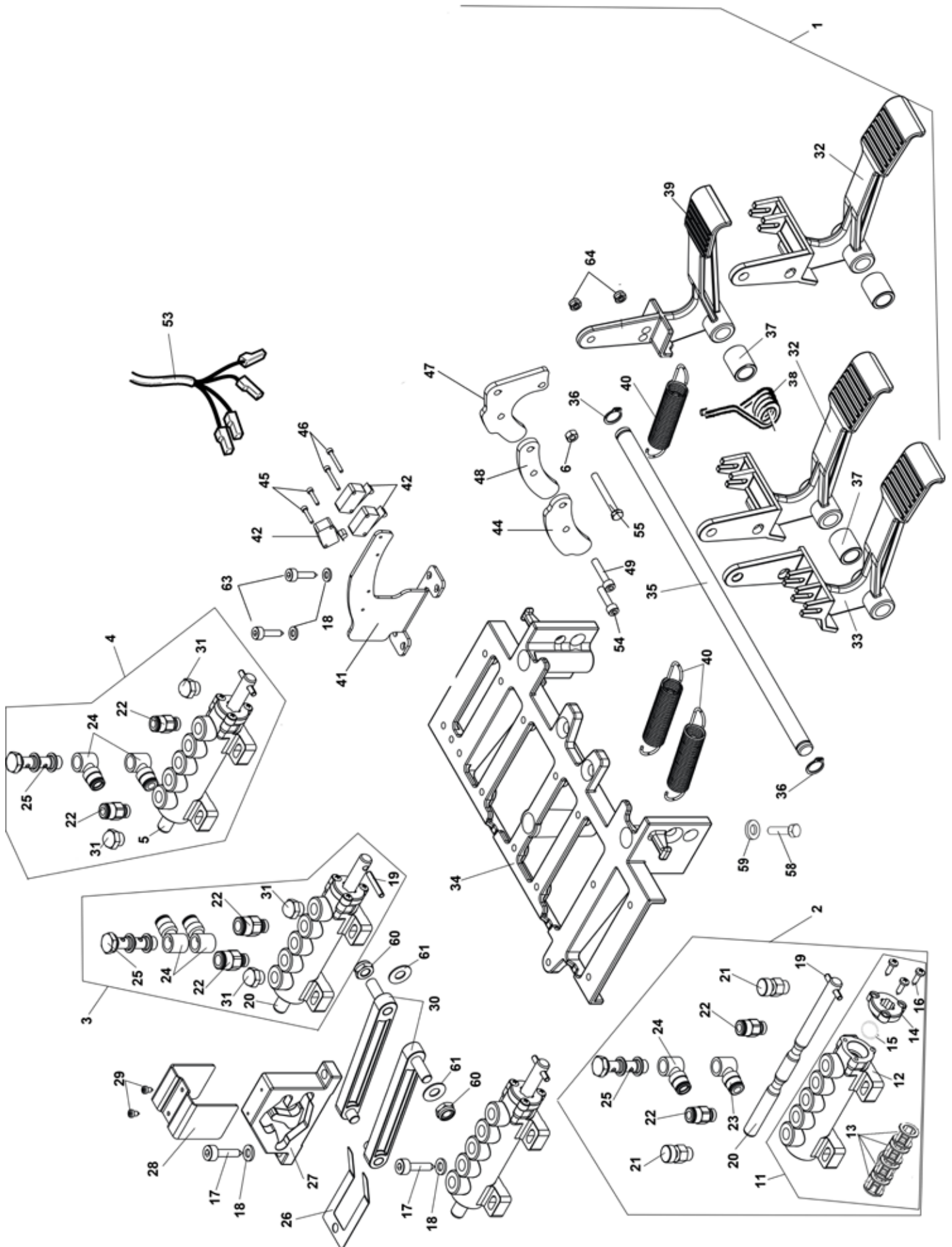

<b>Rif. Ref.</b>	<b>Codice Code</b>	<b>Descrizione</b>	<b>Description</b>
1	2033138	PEDALIERA AUTOM. INVERTER	PEDAL CONTROL UNIT
2	2002531	GR.VALVOLA RIBALT. LINEA	TILTING CONTROL VALVE
3	2002529	GR.VALVOLA AUTOCENTRANTE	VALVE UNIT
4	2002528	GR.VALVOLA STALLONATORE D.E.	VALVE UNIT
5	3002443	PERNO VALVOLA STALLONATORE	BB D.E. VALVE ROD
6	4399889	DADO M 6 6S ZNT 5588	NUT M6
11	2002444	GR.VALVOLA LINEA SENZA PERNO	VALVE UNIT WITHOUT PIN
12	3001583	VALVOLA DISTRIB.-SENZA CHIAVET	DISTRIBUTION VALVE
13	3001584	DISTANZIALE X VALVOLA 3001583	SPACER FOR VALVE 3001583
14	3001585	FLANGIA X VALVOLA 3001583	BRIDE POUR SOUPAPE 3001583
15	4299000	ANELLO OR 9,8x3,85	JOINT OR 9,8x3,85
16	4399899	VITE AUTOF. TCIC 3,5x13 6954	SELF-TAPPING SCREW 3,5x13
17	4398274	VITE AUTOF. TCEI 5,5x26	SELF-TAPPING SCREW 5,5x26
18	4399988	RONDELLA 6 (6,4x12x1,6)ZNT6592	WASHER 6 (6,4x12x1,6)
19	4398783	SPINA ELASTICA D.4x24 6874	SPRING PIN D.4x24
20	3002442	PERNO X VALVOLA GRIFFE/RIBALT.	VALVE PIN
21	4199843	REGOL.SCAR.SILENZ.SVE 1/8"	SILENCER OUTLET ADJUSTER
22	4199893	RACCORDO 6512 1/8"-6 S.R.	RAPIDE QUICK UNION 1/8"-6
23	4199927	RACCORDO 6610 1/8" 6/4 S.RAP.	UNION 1/8" -6
24	4197819	RACCORDO 6610 1/8" 8/6 S.RAP.	QUICK UNION 1/8" 8-6
25	4199928	RACCORDO 1631-02 1/8"	UNION 1/8"
26	4299911	BALESTRA A FORCELLA	FORKED LEAF SPRING
27	4299913	CAMMA DOPPIA	DOUBLE CAM
28	4299910	CAVALLOTTO GUIDA BIELLA	CONNECTING ROD GUIDE
29	4399891	VITE AUTOF.TC+ 2,9x6,5 ZNT	SELF-TAPPING SCREW 2,9x6,5
30	4299912	BIELLA PER CAMME	CONNECTING ROD
31	4193188	SILENZIATORE SPFL 1/8	SILENCER SPFL 1/8
32	3002159	PEDALE COM. AUTOC./STALL. ALL.	PEDAL
33	3002160	PEDALE COM. RIBALT. ALL.	TILTING CONTROL PEDAL
34	3002161	BASAMENTO PEDALIERA	PEDAL BOX BASE
35	3003095	PERNO ALLINEAMENTO PED. L.337	PEDALS ALINGMENT PIN L.337
36	4399864	ANELLO SEEGER E D.12 7435	SEEGER RING D.12
37	3007953	BOCCOLA D.18x12,5x21 PED.INV.	BUSH D.18x12,5x21
38	3017116	MOLLA COMANDO PEDALE	PEDAL CONTROL SPRING
39	3002157	PEDALE INVERT.	PEDAL
40	3018802	MOLLA RICH.PEDALE W.	PEDAL RETURN SPRING
41	3032471	STAFFA SUPP.MICRO PEDA.STD	SUPPORT
42	4593992	MICROINTERUTT.CROUZET	CROUZET MICROSWITCH
44	3032474	CAMMA 2° VEL.PEDALE STD	2ND SPEED CAM
45	4395156	VITE TCEI M 3x16	SCREW 3x16
46	4396382	VITE TCEI M 3x25	SCREW 3x25
47	3032472	CAMMA 1° VEL.PEDALE STD	1ST SPEED CAM
48	3032473	DISTANZIALE CAMME	SPACER
49	4399299	VITE TCEI M 6x30	SCREW 6x30
53	2019722	CAVO SEGNALE	SIGNAL CABLE
54	4399999	VITE TCEI M 6x25	SCREW M6x25
55	4395583	VITE TCEI M 6x60	SCREW M6x60
58	4399946	VITE TE 8x16 8.8 ZNT 5739	SCREW 8x16

<b>Rif. Ref.</b>	<b>Codice Code</b>	<b>Descrizione</b>	<b>Description</b>
59	4399829	RONDELLA 8 (8,4x16x1,5)ZNT6592	WASHER 8 (8,4x16x1,5)
60	4399900	DADO AUTOBL.M 8 BASSO 6.S 7474	SELF-LOCKING NUT M8
61	4399894	MOLLA TAZZA 8,2X18X1 UNI 8737 -	BELLEVILLE WASHER 8,2x18x1
62	4397649	VITE TE 6x50 8.8 PF ZNT 5737	SCREW 6x50 8.8
63	4398273	VITE AUTOF. TCEI 5,5x19 ZNT	SELF-TAPPING SCREW 5,5x19
64	4399893	DADO AUTOBL.M 6 BASSO.6S. 7474	SELF-LOCKING NUT M6

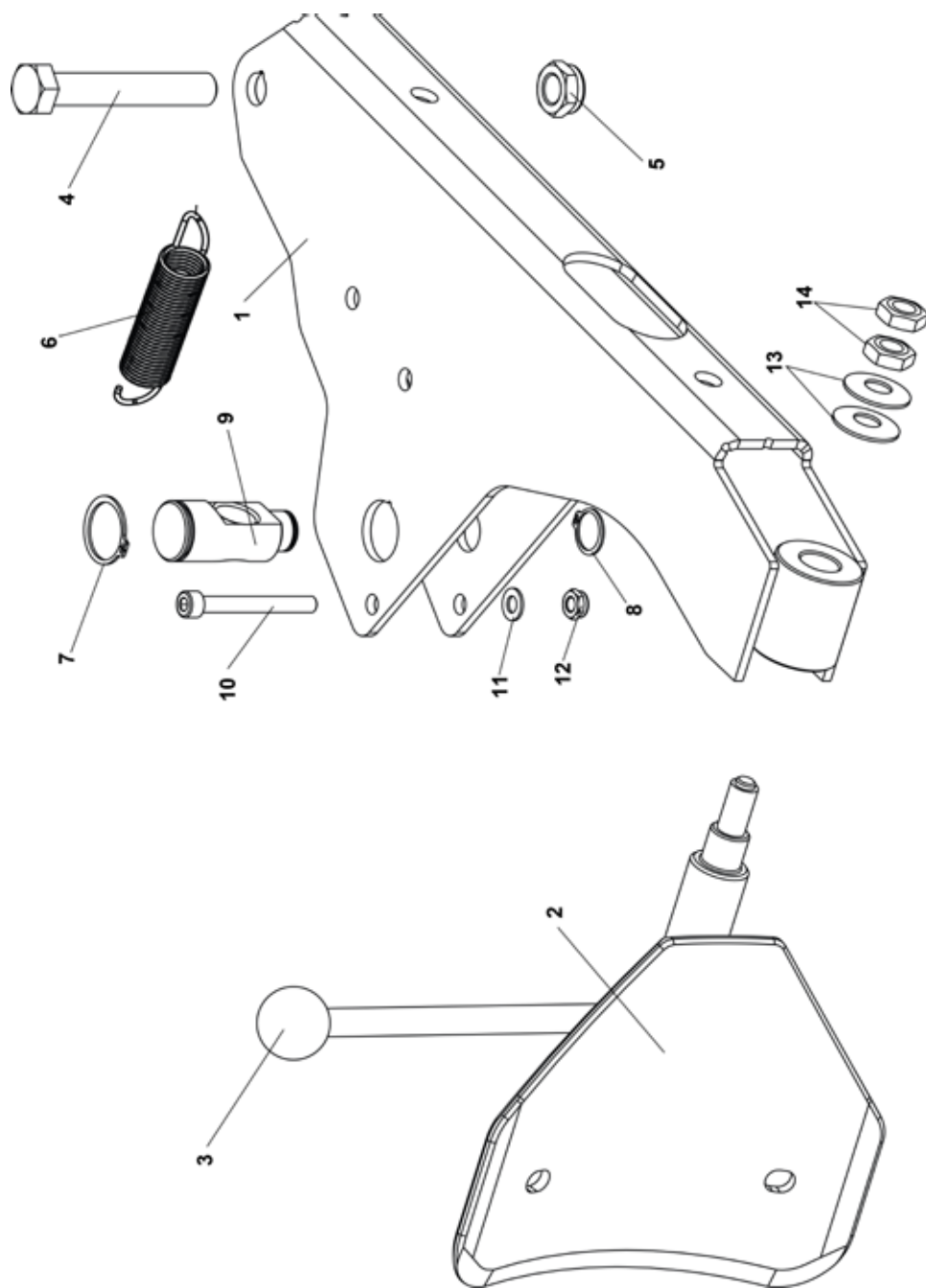

<b>Rif. Ref.</b>	<b>Codice Code</b>	<b>Descrizione</b>	<b>Description</b>
1	7035803	BRACCIO STALLONATORE	BEAD BREAKING ARM
2	2135371	PALETTA STALL. COMPL.	PALE DECOLLE-TALONS
3	4299952	POMOLO D.14	POMMEAU D.14
4	4399945	VITE TE 16x100 8.8 P.F. 5737	VIS TE 16x100
5	4399963	DADO AUTOBL.M16 BASSO.6S. 7474	ECROU DE VERROUILLAGE M16
6	3000114	MOLLA BRACCIO STALLONATORE	RESSORT BRAS DECOLLEUR
7	4399979	ANELLO SEEGER E D.30 7435	BAGUE SEEGER D.30
8	4399975	ANELLO SEEGER E D.20 7435	BAGUE SEEGER D.20
9	3007894	PERNO ORIENTABILE ASTA	PIVOT
10	4398878	VITE TCEI M 8x70	SCREW 8x70
11	4399829	RONDELLA 8 (8,4x16x1,5)ZNT6592	WASHER 8 (8,4x16x1,5)
12	4399900	DADO AUTOBL.M 8 BASSO	SELF-LOCKING NUT M8
13	4398899	MOLLA TAZZA 14.3x34x1,5	RESSORT BELLEVILLE 14.3x34x1,5
14	4396941	DADO M14 6S BASSO ZNT 5589	ECROU M14

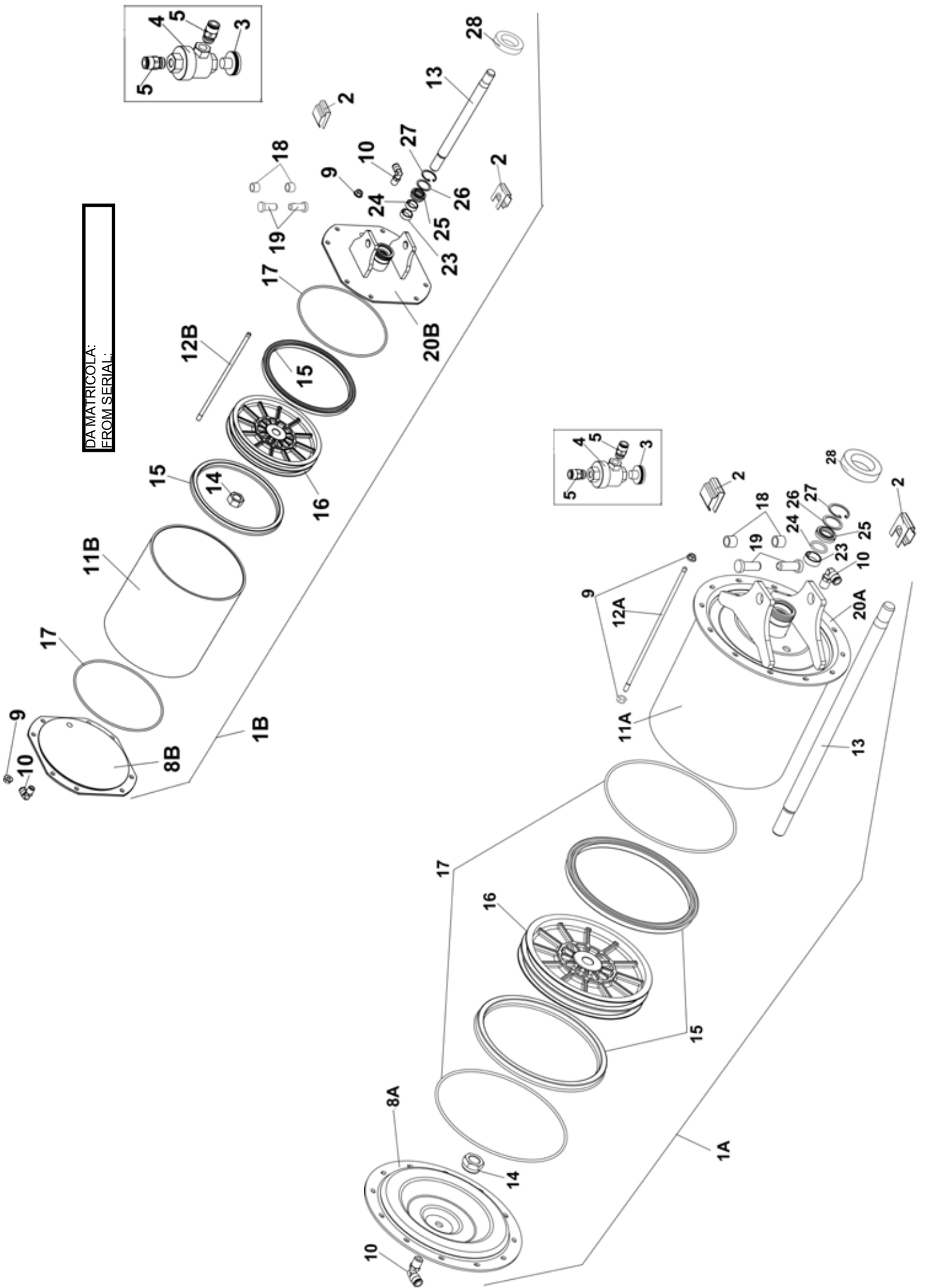



<b>Rif. Ref.</b>	<b>Codice Code</b>	<b>Descrizione</b>	<b>Description</b>
1A	2035725	GR.CILINDRO STALL. D. 200	BEAD BREAKER CYLINDER D.200
2	3009012	MOLLA A CLIPS	SPRING
3	4198808	SILENZIATORE 1/4" SPEC. D.24	SILENCER 1/4"
4	4199671	VALVOLA SCARICO RAPIDO DA 1/4"	QUICK RELIEF VALVE 1/4"
5	4198884	RACCORDO S6510 1/4"-8 S.R.	QUICK UNION 1/4"
8A	3035722	FLANGIA POSTERIORE CILINDRO	REAR FLANGE
9	4398007	DADO FLANGIATO M6 ZNT DIN 6923	FLANGED NUT M6
10	4198578	RACCORDO 6520 1/4"-8/6 GIREV.	ROTATING UNION 1/4" 8-6
11A	3035721	CAMICIA CILINDRO STALLONATORE	CYLINDER LINER
12A	3035723	TIRANTE CILINDRO STALL.	CYLINDER TIE ROD
13	3031738	ASTA CIL.STALL.S.E. D 200 (SHA)	CYLINDER SHAF
14	4394969	DADO M18x1,5 MEDIO 5588 ZNT	NUT M18x1.5
15	4193622	GUARNIZIONE 198X180X12	SEAL 198X180X12
16	3035724	PISTONE CILINDRO STALL.	CYLINDER PISTON
17	4198145	ANELLO OR 4775 D.196.40x3.53	O-RING D.196.4x3.53
18	3000117	BOCCOLA PER CILINDRO STALL.	DOUILLE
19	3009017	PERNO FULCRO CIL. STALL.	CYLINDER TRUNNION
20A	2135716	FLANGIA ANTERIORE CILINDRO	FRONT FLANGE
23	4298823	FASCIA DI GUIDA ASTA CILINDRO	NYLON GUIDE
24	4298168	ANELLO OR 3081 D.20.29x2.62	O-RING 20.29x2.62
25	3199601	ANELLO RASCH.BID.L7 NSW 20 30	SCRAPER
26	4398146	RASAMENTO 24x30x1	STEEL SHIM 24x30x1
27	3199599	ANELLO SEEGER I D.30 JV	SEEGER RING D.30
28	3035977	AMMORTIZZATORE D. 22X75X20	SHOCK-ABSORBER D.22x75x20

<b>Rif. Ref.</b>	<b>Codice Code</b>	<b>Descrizione</b>	<b>Description</b>
1B	2038743	GR.CILINDRO STALL. D. 200	BEAD BREAKER CYLINDER D.200
2	3009012	MOLLA A CLIPS	SPRING
3	4198808	SILENZIATORE 1/4" SPEC. D.24	SILENCER 1/4"
4	4199671	VALVOLA SCARICO RAPIDO DA 1/4"	QUICK RELIEF VALVE 1/4"
5	4198884	RACCORDO S6510 1/4"-8 S.R.	QUICK UNION 1/4"
8B	3038694	FLANGIA POSTERIORE CILINDRO	REAR FLANGE
9	4398007	DADO FLANGIATO M6 ZNT DIN 6923	FLANGED NUT M6
10	4198578	RACCORDO 6520 1/4"-8/6 GIREV.	ROTATING UNION 1/4" 8-6
11B	3038744	CAMICIA CILINDRO STALLONATORE	CYLINDER LINER
12B	3038746	TIRANTE CILINDRO STALL.	CYLINDER TIE ROD
13	3031738	ASTA CIL.STALL.S.E. D 200 (SHA)	CYLINDER SHAF
14	4394969	DADO M18x1,5 MEDIO 5588 ZNT	NUT M18x1.5
15	4193622	GUARNIZIONE 198X180X12	SEAL 198X180X12
16	3035724	PISTONE CILINDRO STALL.	CYLINDER PISTON
17	4198145	ANELLO OR 4775 D.196.40x3.53	O-RING D.196.4x3.53
18	3000117	BOCCOLA PER CILINDRO STALL.	DOUILLE
19	3009017	PERNO FULCRO CIL. STALL.	CYLINDER TRUNNION
20B	2138745	FLANGIA ANTERIORE CILINDRO	FRONT FLANGE
23	4298823	FASCIA DI GUIDA ASTA CILINDRO	NYLON GUIDE
24	4298168	ANELLO OR 3081 D.20.29x2.62	O-RING 20.29x2.62
25	3199601	ANELLO RASCH.BID.L7 NSW 20 30	SCRAPER
26	4398146	RASAMENTO 24x30x1	STEEL SHIM 24x30x1
27	3199599	ANELLO SEEGER I D.30 JV	SEEGER RING D.30
28	3035977	AMMORTIZZATORE D. 22X75X20	SHOCK-ABSORBER D.22x75x20

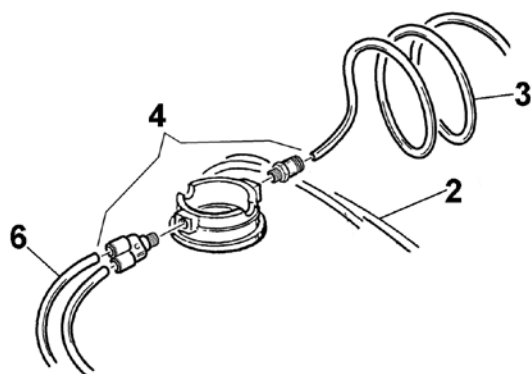
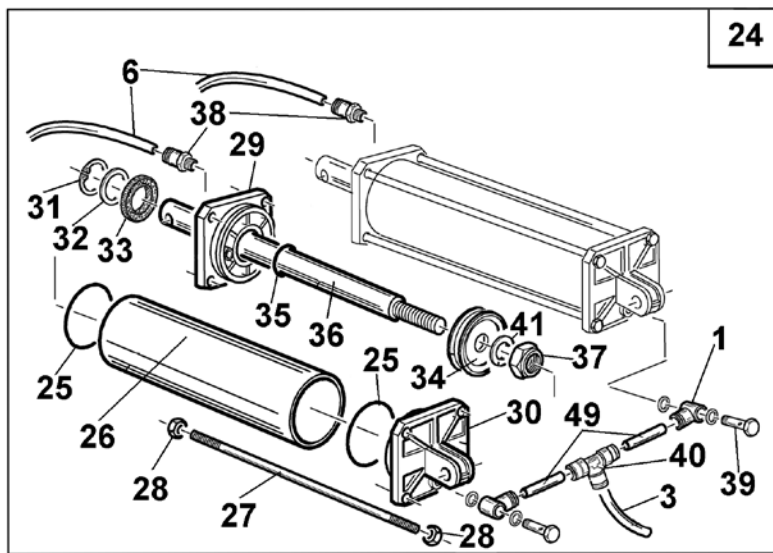
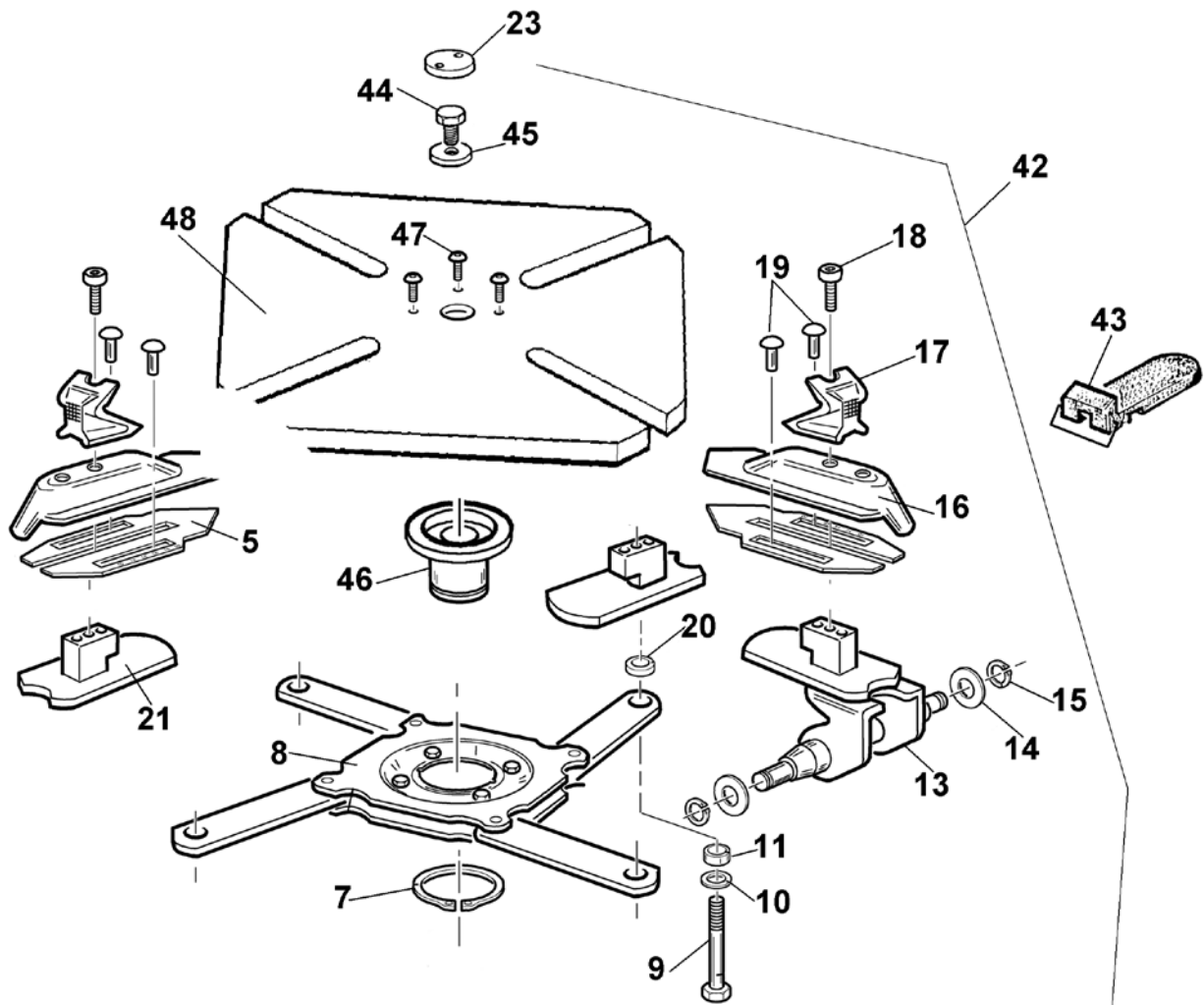

<b>Rif. Ref.</b>	<b>Codice Code</b>	<b>Descrizione</b>	<b>Description</b>
1	4197819	RACCORDO 6610 1/8" 8/6 S.RAP.	QUICK UNION 1/8" 8-6
2	3099335	TUBO ELASTOLAN D. 8X6 L=750	HOSE 8x6 L=750
3	3016820	SPIRALE RILSAN 8X6 L=560	RILSAN SPIRAL HOSE 8X6 L=560
4	4295067	RACCORDO GIREVOLE "Y"	ROTATING UNION
5	3035974	PIASTRINA AUT.UNIF.19/20"	PLATE 19/20"
6	3000898	TUBO ELASTOLAN D. 8X6 L=260	HOSE 8x6 L=260
7	4399932	ANELLO SEEGER EST. D.62	SEEGER RING D.62
8	2007414	FLANGIA AUTOC.18-19-20-22 UNIF.	18/19/20" TURNTABLE FLANGE
9	4398838	VITE TE 12x1,25x45 8.8 PF	SCREW 12x1,25x45
10	4398637	RONDELLA 12x21x2,5	WASHER D.12x21x2,5
11	3006880	DISTANZIALE BIELLA UNIF.12x18x9	SPACER
12	2033215	GR. AUTOCENTRANTE + MOZZO NO GT	24" TURNTABLE NO GT
13	2133769	GUIDA SCORREVOLE PERNO	PIN SLIDE GUIDE
14	4399981	RONDELLA 12 (13x24x2,5)	WASHER 12 (13x24x2,5)
15	4399864	ANELLO SEEGER E D.12	SEEGER RING D.12
16	3006255	SCORREVOLE UNIF.	SLIDE
17	3002297	GRIFFA BLOCCAGGIO MAGGIORATA	CLAMP
18	4398037	VITE TCEI M10x1,25x25	SCREW 10x1,25x25
19	3015187	PERNO GUIDA SCORREVOLE	GUIDE PIN
20	3006879	DISTANZIALE AUTOC. UNIF.	SPACER
21	2115755	GUIDA SCORREVOLE COMPLETA	COMPLETE SLIDE GUIDE
23	3000062	PROTEZIONE CENTRALE PIATTO	PROTECTION
24	2033767	GR.CILINDRO AUT.20" INT.	20" TURNTABLE CYLINDER
25	4298822	ANELLO OR 842 D.68,26x3,53	O-RING D.68,26x3,53
26	3008042	CAMICIA CIL. 20" L=345	CYLINDER LINER 20" L=345
27	3007941	VITE SPECIALE TE M8x369	SPECIAL SCREW M8x369
28	4397678	DADO FLANGIATO M8	FLANGED NUT M8
29	3015024	FLANGIA ANTER.D.75-PRF	FLANGE
30	3015023	FLANGIA POSTER.D.75-PRF	FLANGE
31	3199599	ANELLO SEEGER I D.30 JV	SEEGER RING D.30
32	4398146	RASAMENTO 24x30x1	STEEL SHIM 24x30x1
33	3199601	ANELLO RASCH.BID.L7 NSW 20 30 6/CO	SCRAPER
34	4198856	PISTONE MONOBLOCCO TDUOP D.75	PISTON D.75
35	4299168	ANELLO OR 3081 D.20,29x2,62	O-RING 20,29x2,62
36	3002901	ASTA CILINDRO AUT.20" L=400	CYLINDER ROD 20" L=400
37	4399865	DADO AUTOBL.M12 BASSO.6S.	SELF-LOCKING NUT M12
38	4198954	RACCORDO 6512 1/8"-8 S.R.	QUICK UNION 1/8"
39	4199929	RACCORDO 1631-01 1/8"	UNION 1/8"
40	4198978	RACCORDO 6540 8	UNION
41	4398753	RONDELLA 12,5x30x3	WASHER D.12,5x30x3
42	2035615	GR.AUTOCENTRANTE OTTAG. SL	TURNTABLE
43	3001468	PROTEZ.INTEGRALE GRIFFA COMPL.	CLAMP COVER
44	4395179	VITE TE 16x1,5x45 8.8 ZNT 5740	SCREW TE 16x1,5x45 8.8 5740
45	3009778	RONDELLA SPEC. D.16x47x13-ZNT	WASHER D.16x47x13
46	3032956	MOZZO FILETTATO PIATTI AUTOC.	THREADED HUB
47	4399391	VITE TSPEI M 8x25 10.9 ZNT 5933	SCREW 8x25
48	3035373	PIATTO AUTOCENTRANTE OTTAG. SL	TURNTABLE
49	3016819	TUBO RILSAN D. 8X6 L=75	RILSAN HOSE D.8x6 L=75

**Motori standard**

**Standard motors**

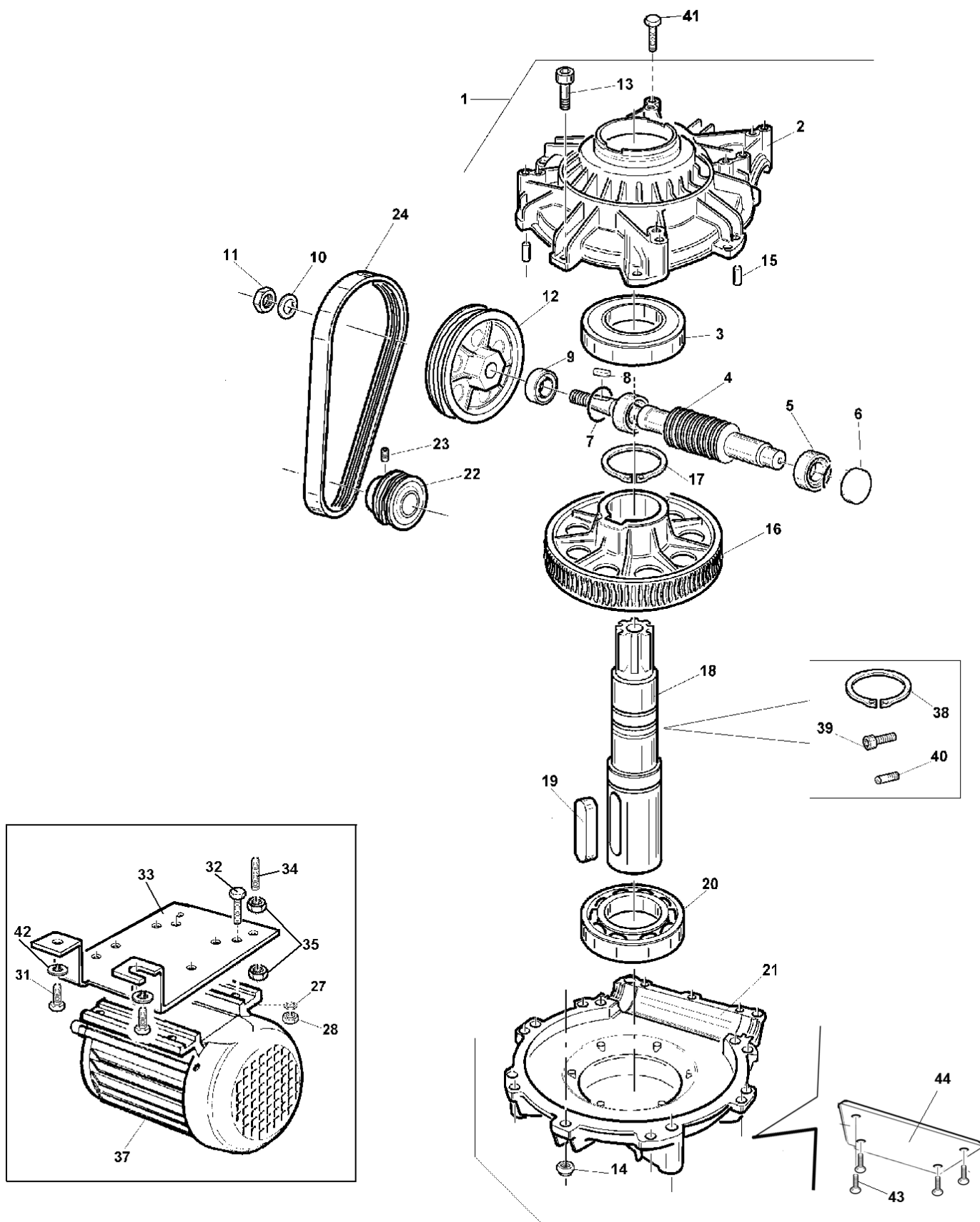

<b>Rif. Ref.</b>	<b>Codice Code</b>	<b>Descrizione</b>	<b>Description</b>
1	2010900	GR. RIDUTT. SMTG AUTO COMPL.	REDUCTION GEAR UNIT
2	3010872	SCATOLA SUPER. RIDUTT.	REDUCTION GEAR BOX
3	4296945	CUSCINETTO 6212 2RS 60x110x22	BEARING 60X110X22
4	3010883	VITE SENZA FINE RID.SMTG AUTO	WORM
5	4296944	CUSCINETTO RULLI CONICI 30204	BEARING
6	3017760	COPERCHIETTO TENUTA IN GOMMA	SEALING CAP
7	4294205	GUARNIZIONE FT D.40X35X4 NBR 75	SEAL D.40X35X4 NBR 75
8	4396947	LINGUETTA 6x6x18 (A) 6604	TAB 6X6X18
9	4296942	ANELLO TENUTA 20x35x10	O-RING 20X35X10
10	4398807	RONDELLA 14 (15x28x2,5)ZNT6592	WASHER 14 (15x28x2,5)
11	4396941	DADO M14 6S BASSO ZNT 5589	NUT M14
12	3010863	PULEGGIA RIDUTTORE	GEARBOX PULLEY
13	4399134	VITE TCEI M 8x30 8.8 5931	SCREW TCEI 8x30 8.8
14	4399900	DADO AUTOBL.M 8 BASSO 6.S 7474	SELF-LOCKING NUT M8
15	4396940	SPINA CIL.RETT. 8x20 6364A	PIN 8X20
16	3010884	RUOTA ELICOIDALE RID.-FINITA	HELICAL GEAR
17	4396946	ANELLO SEEGER E D.60x3 7436	SEEGER RING D.60X3
18	3010885	PERNO PER RUOTA ELICOID.	HELICAL GEAR STUD
19	4396948	LINGUETTA 16x10x70 (A) 6604	TAB 16X10X70
20	4296910	CUSCINETTO 6212 60x110x22	BEARING 60X110X22
21	3010873	SCATOLA INFERIORE RIDUTTORE	BOITE REDUCTEUR
22	3010864	PULEGGIA MOTORE	POULIE MOTEUR
23	4399922	VITE STEI 8x14 P.CIL. 5925	SCREW 8x14
24	4296813	CINGHIA PV 610 J6	BELT
27	4399829	RONDELLA 8 (8,4x16x1,5)ZNT6592	WASHER 8 (8,4x16x1,5)
28	4399976	DADO M 8 6S ZNT 5588	NUT M8
30	4398662	ROND.GROWER D.10 ZNT	GROWER WASHER D.10
31	4399966	VITE TE 10x20 8.8 5739	SCREW M10x20 - 8.8
32	4399935	VITE TE 8x25 8.8 5739	SCREW TE M8X25 8.8
33	3000149	SUPP. MOTORE	MOTOR SUPPORT
34	3031873	BARRA FILETTATA M10 L=65	THREADED BAR M10 L=65
37	4599924	MOTORE EL.3PH 230/400V 50Hz-SMTG T	MOTOR
37A	4598919	MOTORE 2v. 3PH 400V 50HZ	2v. MOT. 3PH 400V 50HZ KW 0,75/1,125
37B	4595016	MOTORE 1PH HP1,2 240V.50Hz	1PH HP1,2 240V.50Hz MOTOR
38	4396700	ANELLO SEEGER E D.50x2 7436	SEEGER RING D.50x2
39	4399964	VITE TE M 6x10	SCREW TE M6 x 10
40	3001996	VITE PER RACCORDO GIREVOLE GT	SCREW FOR ROTATING UNION GT
41	4398664	VITE TE 10x70 8.8 PF ZNT 5737	SCREW TE M10x70
42	4398662	ROND.GROWER D.10 ZNT 1751	GROWER WASHER D.10
43	4399120	VITE TSPEI M10x20 10.9 ZNT 5933	SCREW TSPEI M10x20 10.9 ZNT
44	3036098	ORECCHIA ATTACCO NERVATURA	COUPLING TAB

**Motore inverter**

**Inverter motor**

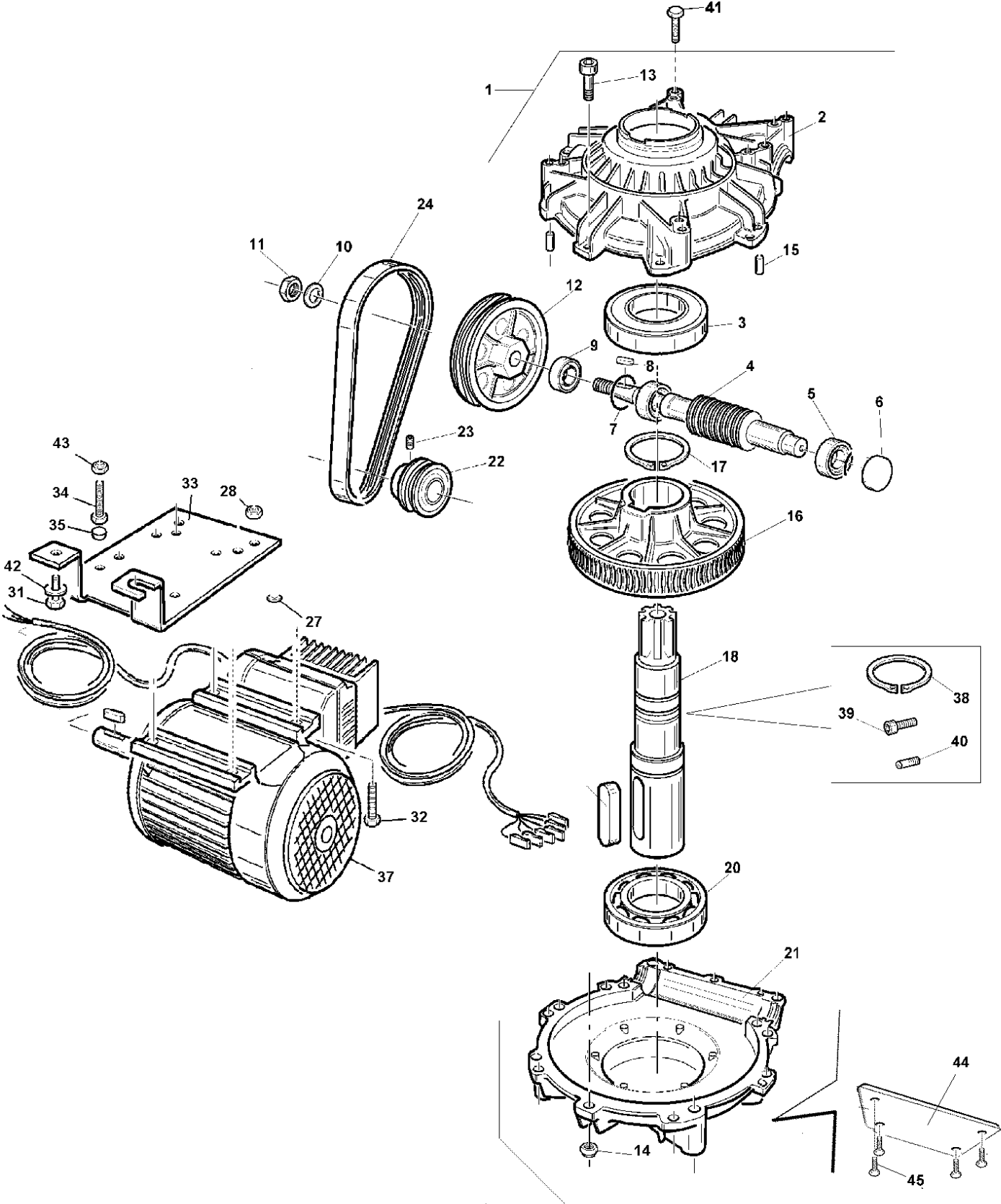



<b>Rif. Ref.</b>	<b>Codice Code</b>	<b>Descrizione</b>	<b>Description</b>
1	2010900	GR. RIDUTT. SMTG AUTO COMPL.	REDUCTION GEAR UNIT
2	3010872	SCATOLA SUPER. RIDUTT.	REDUCTION GEAR BOX
3	4296945	CUSCINETTO 6212 2RS 60x110x22	BEARING 60X110X22
4	3010883	VITE SENZA FINE RID.SMTG AUTO	WORM
5	4296944	CUSCINETTO RULLI CONICI 30204	BEARING
6	3017760	COPERCHIETTO TENUTA IN GOMMA	SEALING CAP
7	4294205	GUARNIZIONE FT D.40X35X4 NBR 75	SEAL D.40X35X4 NBR 75
8	4396947	LINGUETTA 6x6x18 (A) 6604	TAB 6X6X18
9	4296942	ANELLO TENUTA 20x35x10	O-RING 20X35X10
10	4398807	RONDELLA 14 (15x28x2,5)ZNT6592	WASHER 14 (15x28x2,5)
11	4396941	DADO M14 6S BASSO ZNT 5589	NUT M14
12	3010863	PULEGGIA RIDUTTORE	GEARBOX PULLEY
13	4399134	VITE TCEI M 8x30 8.8 5931	SCREW TCEI 8x30 8.8
14	4399900	DADO AUTOBL.M 8 BASSO 6.S 7474	SELF-LOCKING NUT M8
15	4396940	SPINA CIL.RETT. 8x20 6364A	PIN 8X20
16	3010884	RUOTA ELICOIDALE RID.-FINITA	HELICAL GEAR
17	4396946	ANELLO SEEGER E D.60x3 7436	SEEGER RING D.60X3
18	3010885	PERNO PER RUOTA ELICOID.	HELICAL GEAR STUD
19	4396948	LINGUETTA 16x10x70 (A) 6604	TAB 16X10X70
20	4296910	CUSCINETTO 6212 60x110x22	BEARING 60X110X22
21	3010873	SCATOLA INFERIORE RIDUTTORE	BOITE REDUCTEUR
22	3010864	PULEGGIA MOTORE	POULIE MOTEUR
23	4399922	VITE STEI 8x14 P.CIL. 5925	SCREW 8x14
24	4296813	CINGHIA PV 610 J6	BELT
27	4399998	RONDELLA 6 (6,4x12x1,6)ZNT6592	WASHER 6 (6,4x12x1,6)
28	4395456	DADO M 6 6S BASSO ZNT 5589	NUT M6
30	4398662	ROND.GROWER D.10 ZNT	GROWER WASHER D.10
31	4399228	VITE TE 10x25 8.8 5739	SCREW M10x25 - 8.8
32	4394955	VITE TE 6x25 8.8 5739	SCREW TE M6X25 8.8
33	3031102	SUPP. MOTORE	MOTOR SUPPORT
34	4399786	VITE TE 10x30 8.8 ZNT 5739	SCREW 10x30
35	3000164	PUNTALE PER TENDICINGHIA	SHOE
37	4599924	MOTORE EL.3PH 230/400V 50Hz-SMTG T	MOTOR
38	4396700	ANELLO SEEGER E D.50x2 7436	SEEGER RING D.50x2
39	4399964	VITE TE M 6x10	SCREW TE M6 x 10
40	3001996	VITE PER RACCORDO GIREVOLE GT	SCREW FOR ROTATING UNION GT
41	4398664	VITE TE 10x70 8.8 PF ZNT 5737	SCREW TE M10x70
42	4398662	ROND.GROWER D.10 ZNT 1751	GROWER WASHER D.10
43	4399967	DADO M10 6S BASSO ZNT 5589	NUT M10
44	3036098	ORECCHIA ATTACCO NERVATURA	COUPLING TAB
45	4399120	VITE TSPEI M10x20 10.9 ZNT 5933	SCREW TSPEI M10x20 10.9 ZNT

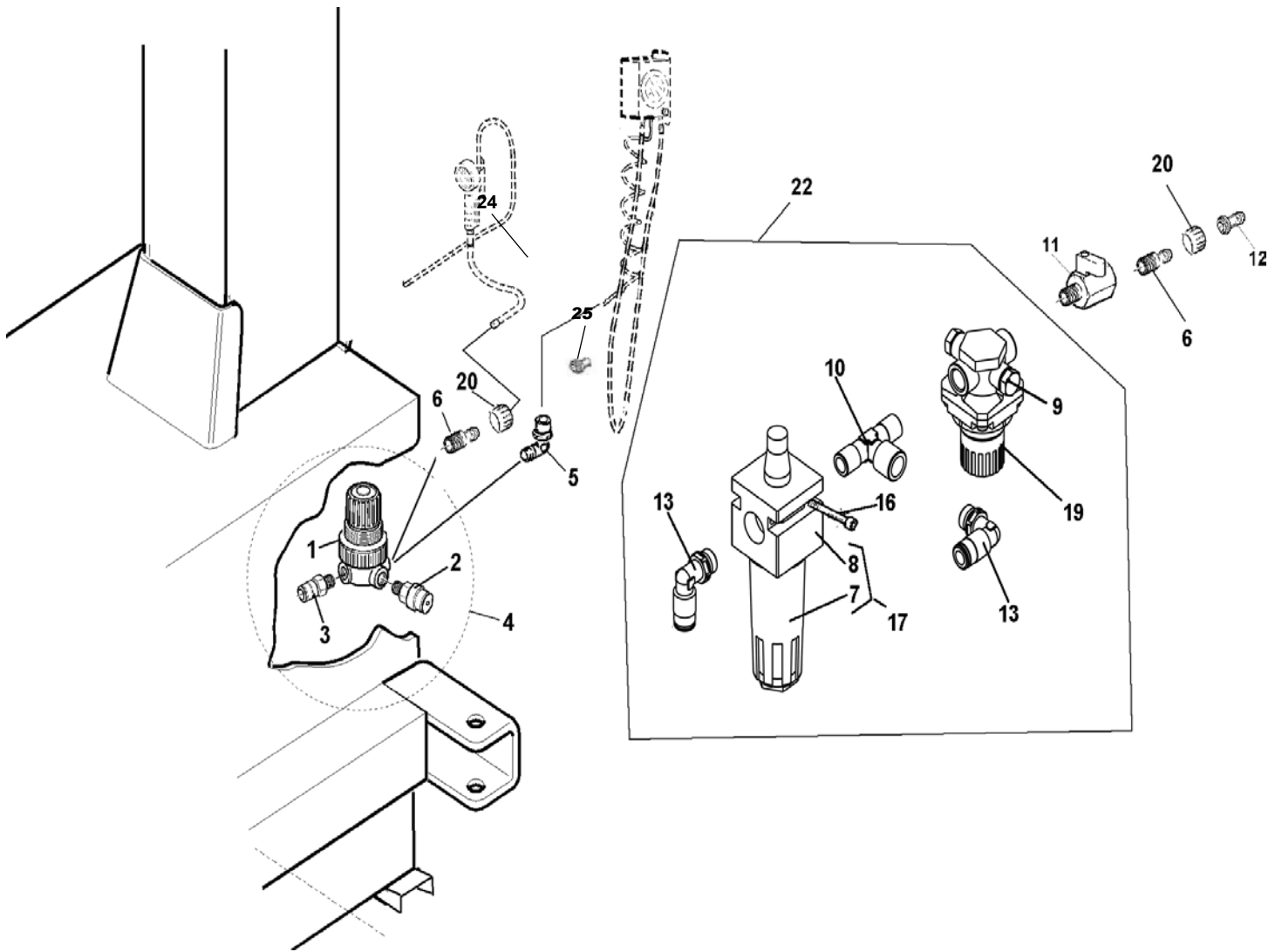

<b>Rif. Ref.</b>	<b>Codice Code</b>	<b>Descrizione</b>	<b>Description</b>
1	4198173	REGOLATORE 1/4" 0-3,5 BAR	REGULATOR 1/4" 0-3,5 BAR
2	4198435	VALV.SIC.1/8"0/4 BAR+RIV.+CAP.	SAFETY VALVE 1/8" 0/4 BAR
3	4198884	RACCORDO 6510 1/4"-8 S.RAPIDO	UNION 6510 1/4"
4	2010781	GR.REGOLAT.4 BAR USC. GT CE	4 BAR PRESSURE REGULATOR UNIT
5	4198578	RACCORDO 6520 1/4"-8/6 GIREV.	ROTATING UNION 1/4"-8/6
6	4199797	RACCORDO 9A/M 1/4"	UNION 9A/M 1/4"
7	4196316	TAZZA LUBRIFICATORE	LUBRICATOR CUP
8	4196315	CORPO LUBRIFICATORE	LUBRICATOR
9	4199161	TAPPO MASCHIO 2611 1/8	PLUG
10	4198973	RACCORDO 2070 1/4" MFM	UNION
11	4196354	VALVOLA MVS 2901 DF 1/4"	VALVE MVS 2901 DF 1/4"
12	4199987	ATTACCO RESCA 2P 1/4 8	UNION 1/4
13	4198883	RACCORDO 6500 1/4"-8 S.RAPIDO	QUICK UNION 6500 1/4"-8
16	4396593	VITE TCEI M 4x40 8.8	SCHRAUBE 4x40
17	4193489	LUBRIFIC.1/4"	LUBRICATOR
19	4198951	REGOLATORE 1/4" 0,5-10 BAR	REGULATOR
20	4199077	DADO FRESATO 11A 1/4"	NUT 1/4"
22	2038751	GRUPPO LUBRIFICATORE + REGOLATORE	LUBRICATOR
25	3007754	TAPPO RACC.CON GHIERA	UNION + RING NUT



**GIULIANO INDUSTRIAL S.p.a. - Via Guerrieri, 6 - 42015 Correggio (RE) ITALY**