

**S 53**

**MANUALE PER IL PERSONALE TECNICO  
TECHNICAL MANUAL**

**Comprende:**

- Esploso con elenco ricambi
- Schema elettrico
- Schema oleodinamico

***Includes:***

- *Exploded view with spare parts list*
- *Electric diagram*
- *Oleodynamic scheme*



**SICE**  
AUTOMOTIVE EQUIPMENT

*Ed. 02/2008*



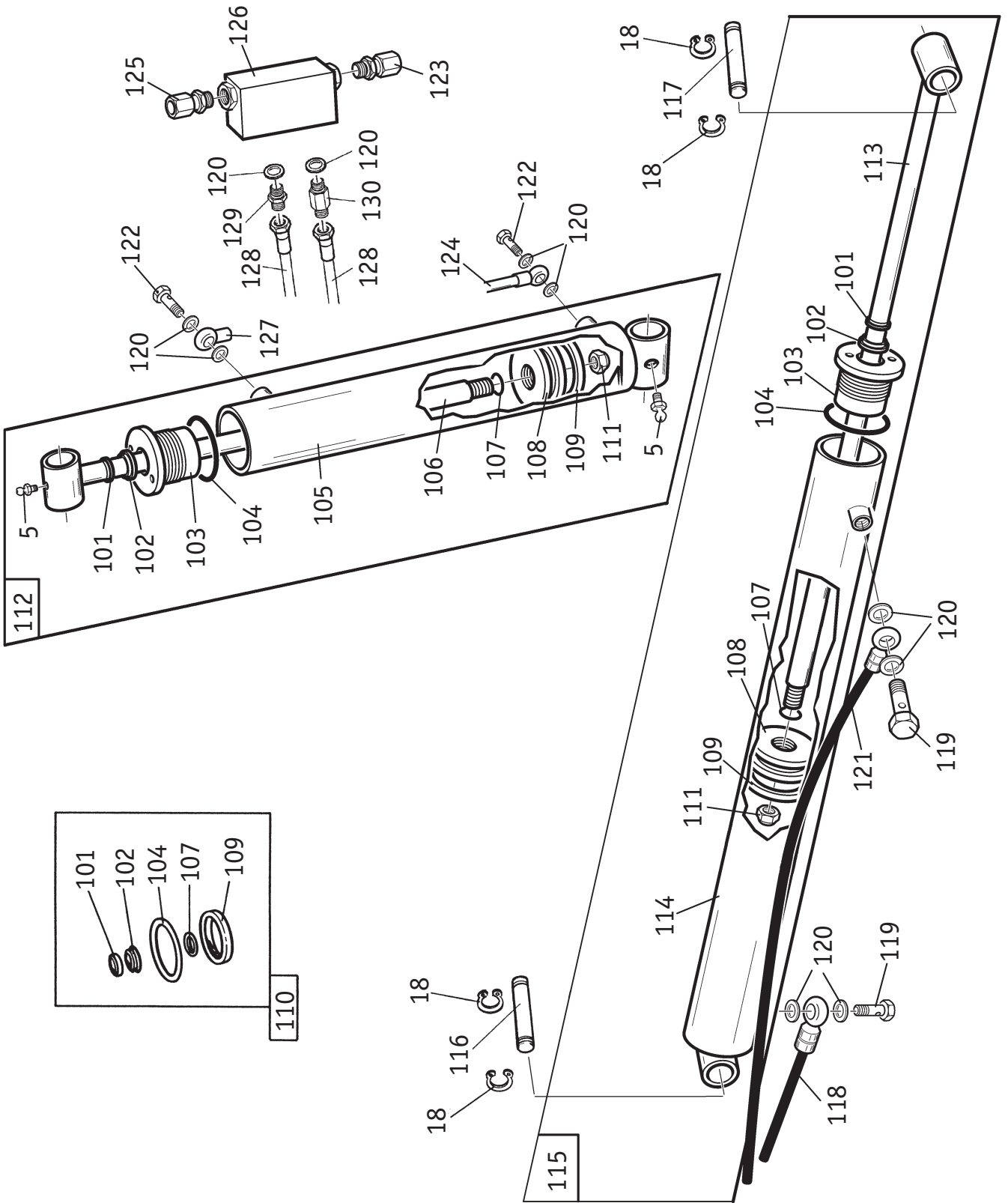



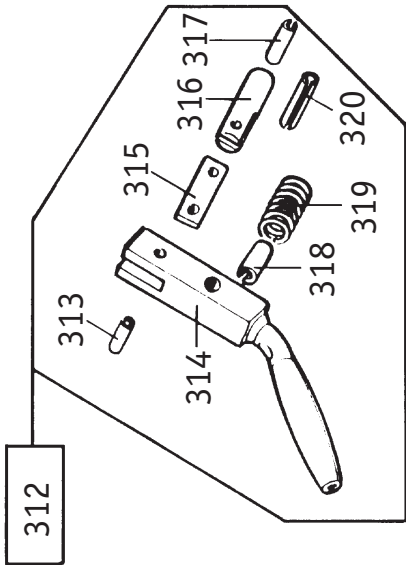
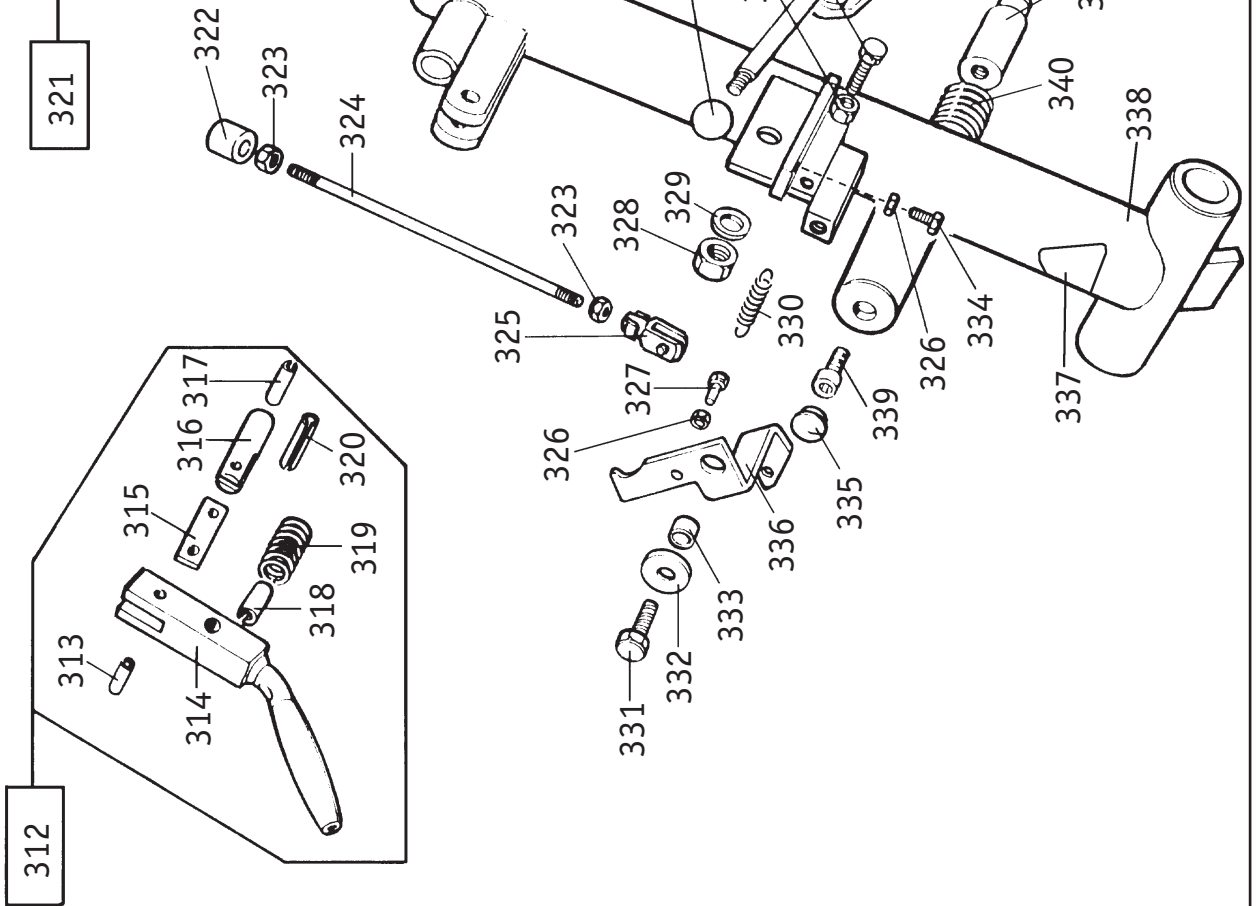
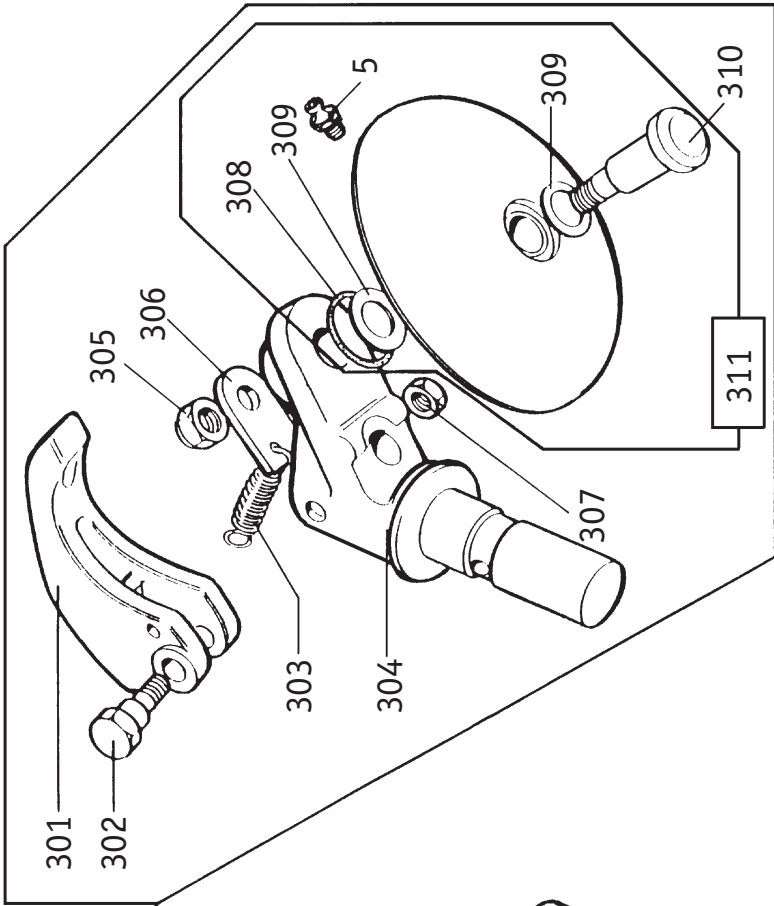

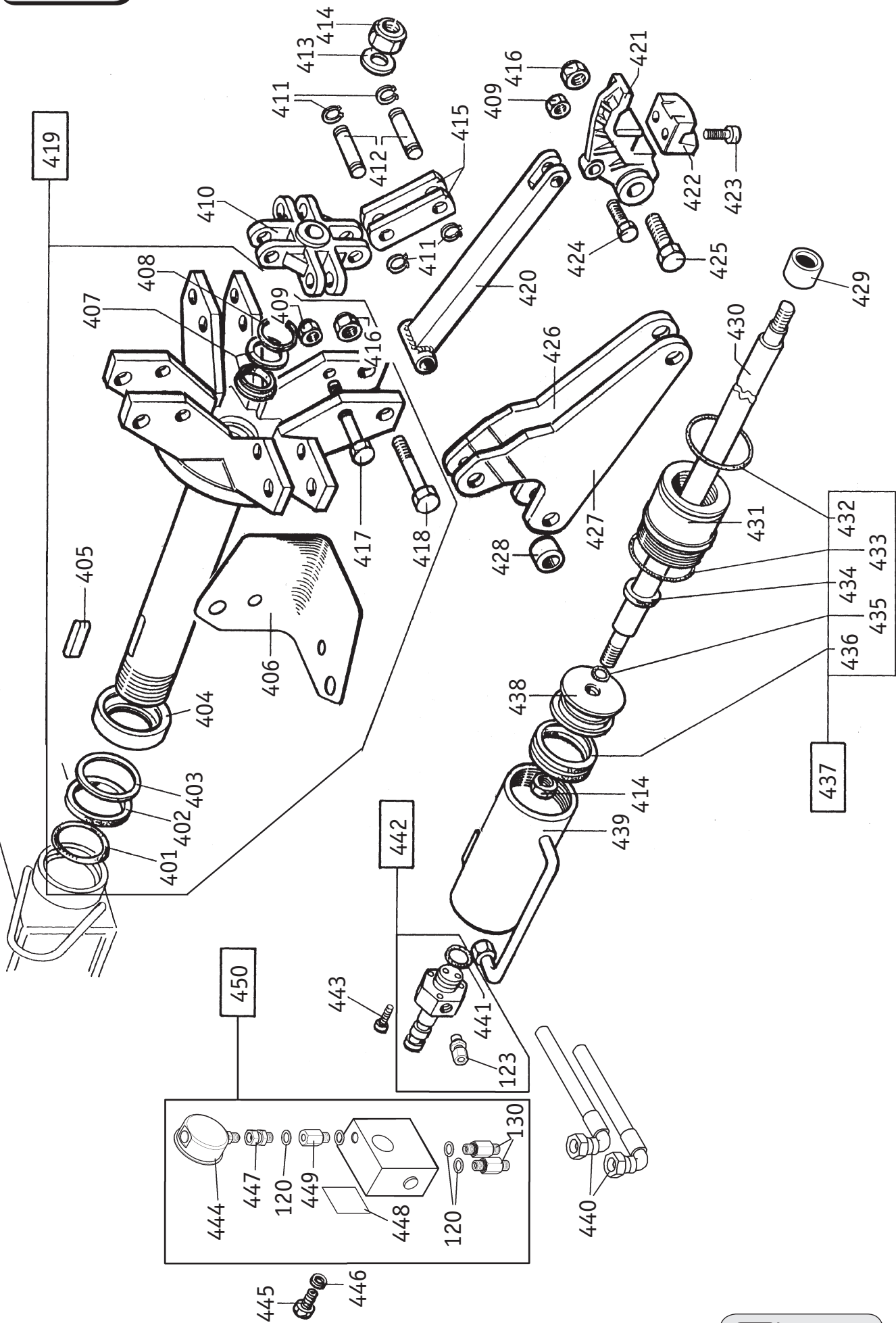

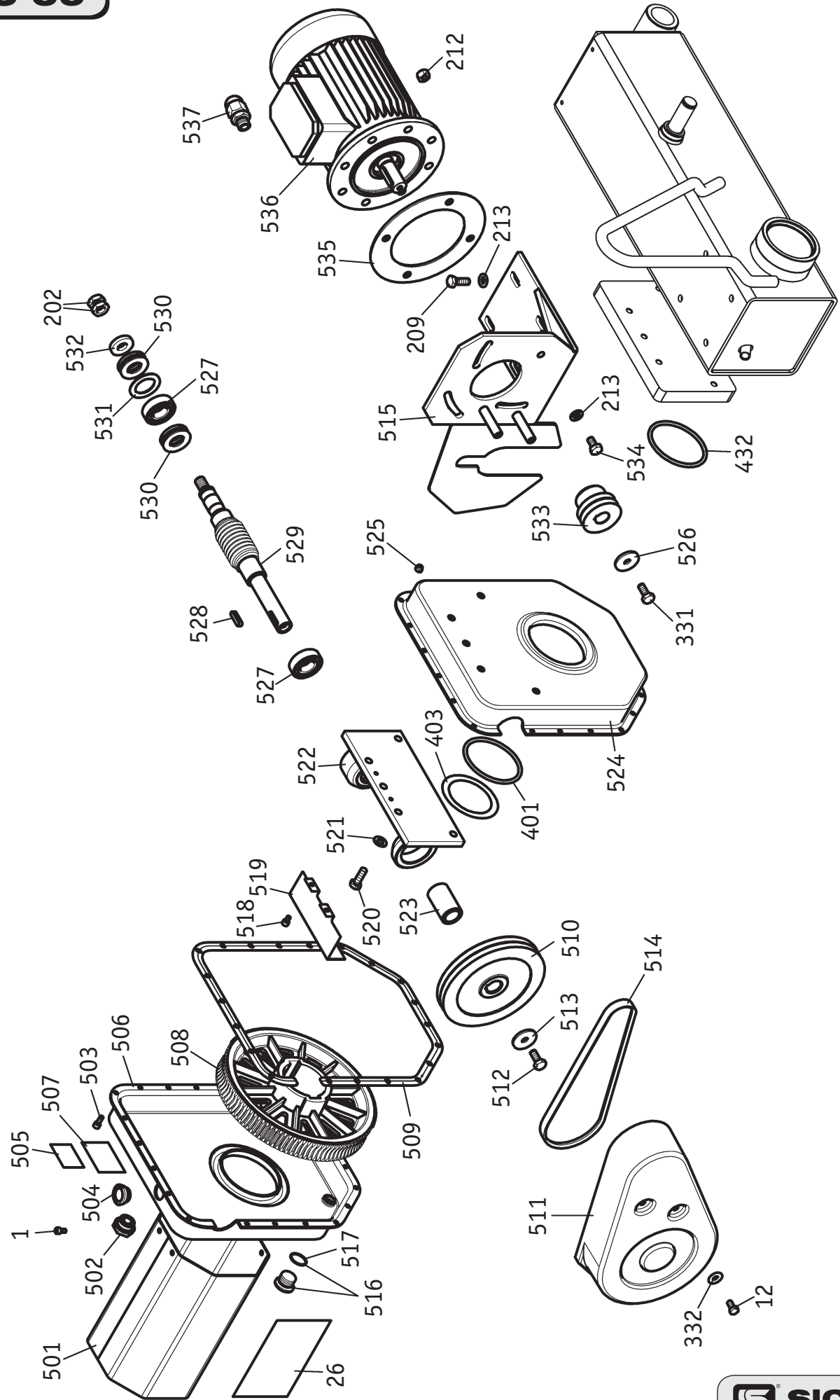

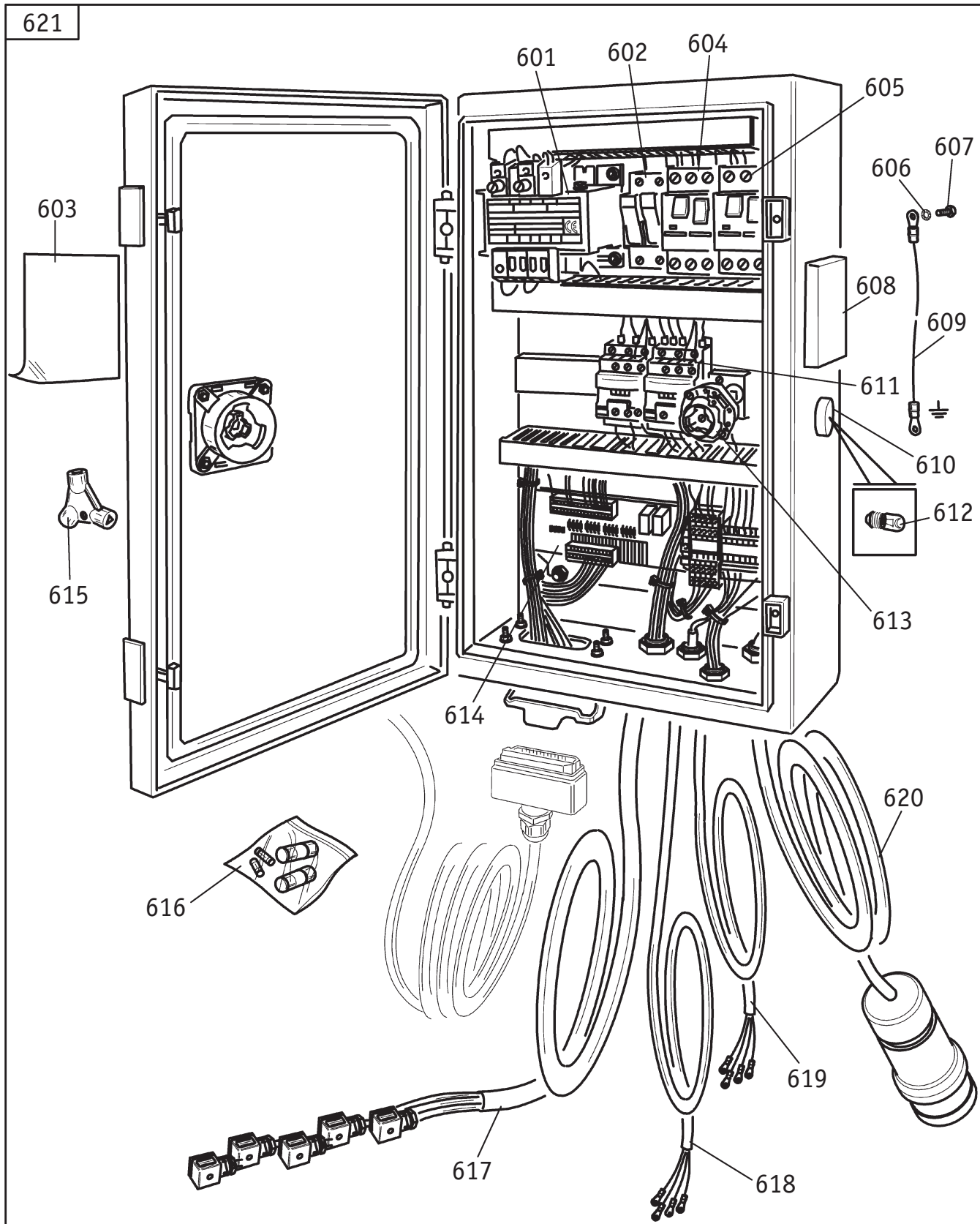



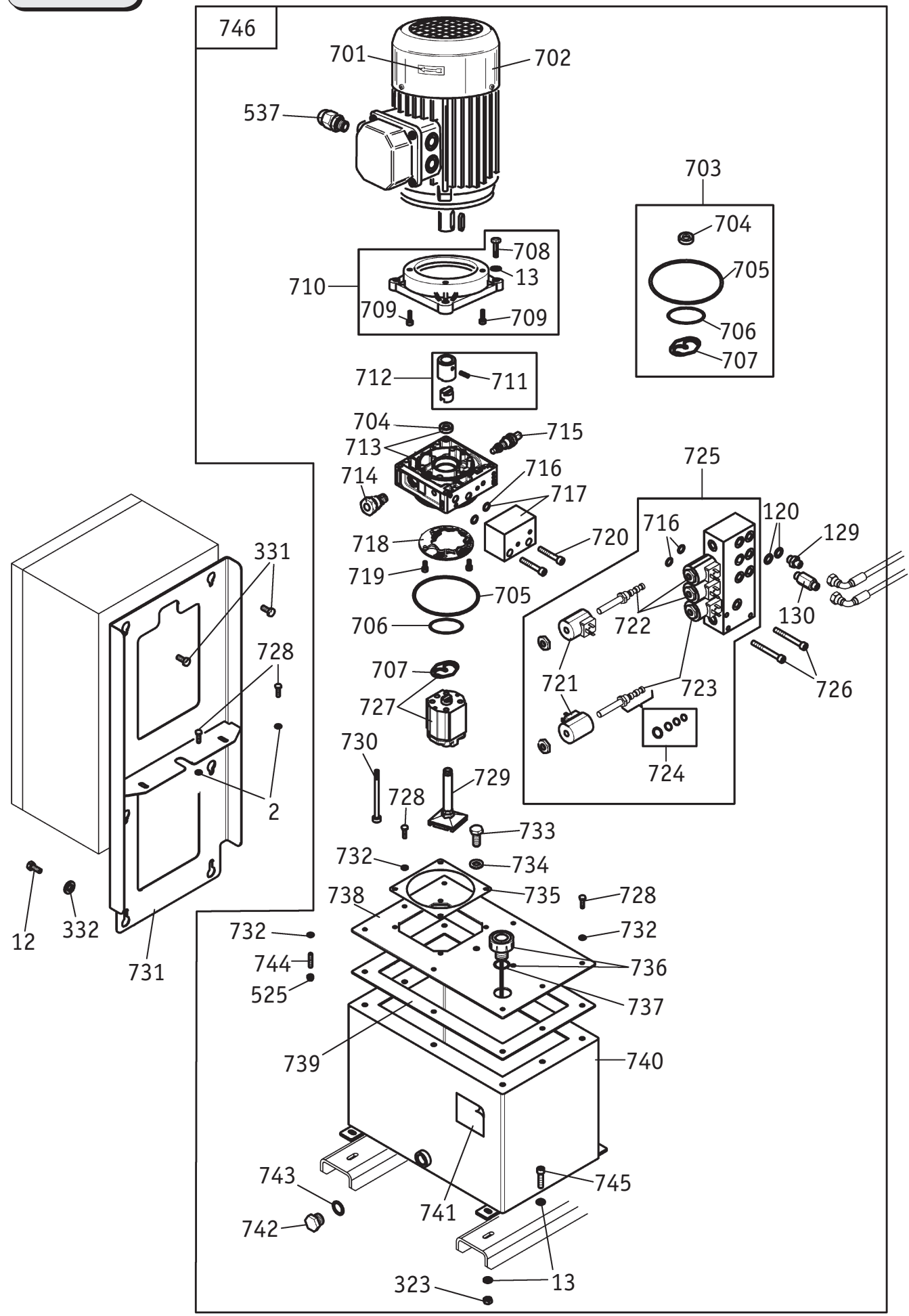

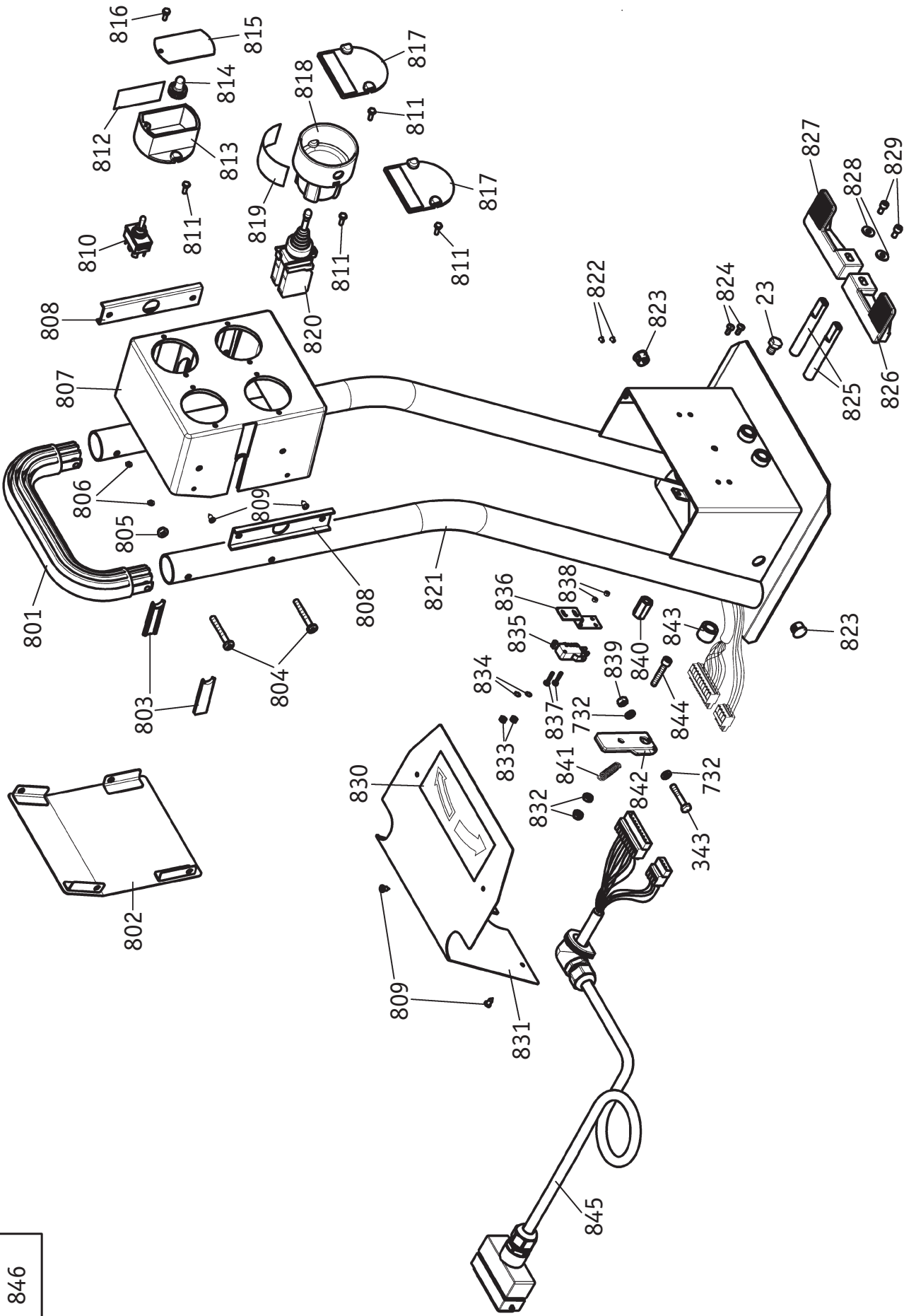

846

Rif. Ref.	Codice Code	Descrizione	Description
1	2-00715	VITE TCEI M 6X12	SOCKET HEAD CAP SCREW M 6X12
2	2-00679	ROSETTA D. 6,6X18X1,5	WASHER 6,6X18X1,5
3	3310145	PROTEZIONE TUBO TELAIO	FRAME COVER
4	4-402638	TARGA PERICOLO AUTOCENTRANTE	WARNING LABEL
5	4211478	INGRASSATORE M 6	GREASER M 6
6	3094764	RASAMENTO D. 40,5X65X0,5	WASHER D. 40,5X65X0,5
7A	5-490765	BRACCIO AUTOCENTRANTE COMPLETO (GIALLO)	COMPLETE SELF-CENTERING ARM (YELLOW)
7A	5-490766	BRACCIO AUTOCENTRANTE COMPLETO (ROSSO)	COMPLETE SELF-CENTERING ARM (RED)
7C	5-490767	BRACCIO AUTOCENTRANTE COMPLETO (BLU)	COMPLETE SELF-CENTERING ARM (BLUE)
8	3010661	PERNO BRACCIO AUTOCENTRANTE	BOLT FOR CHUCK ARM
9	3310221	PATTINO PROTEZIONE	SLIDE
10	4206406	SOTTOTAPPO D. 13	UNDERCAP D. 13
11	4-405152	TARGA PERICOLO	WARNING LABEL
12	2-00372	VITE TE M 8X16	HEXAGON HEAD CAP SCREW M 8X16
13	2-00212	RONDELLA D. 8	WASHER FOR HEX CAP SCREW M 8
14	4210088	FASCETTA 10 MM.	HOSE CLAMP 10 MM.
15	4-404563	TELAIO	FRAME
16	3010658	RONDELLA PERNO AUTOCENTRANTE	WASHER FOR SELF-CENTERING PIN
17	2-01032	VITE TE M 14X30	HEXAGON HEAD CAP SCREW M 14X30
18	2-71593	ANELLO EL. D. 24	SEEGER RING D.24
19A	4-404887	SUPPORTO DOTAZIONE (GIALLO)	TOOL SUPPORT (YELLOW)
19B	4-404891	SUPPORTO DOTAZIONE (ROSSO)	TOOL SUPPORT (RED)
19C	4-404894	SUPPORTO DOTAZIONE (BLU)	TOOL SUPPORT (BLUE)
20	2-02773	VITE TC M 5X8	SLOTTED HEAD SCREW M 5X8
21	3310146	PROTEZIONE CILINDRO	CYLINDER COVER
22	3011216	CARTER CILINDRO BRACCIO	SHORT CYLINDER COVER
23	2-01267	VITE TE M 8X12	HEXAGON HEAD CAP SCREW M 8X12
24A	2110117	CARTER CILINDRO (GIALLO)	CYLINDER COVER (YELLOW)
24B	4-402363	CARTER CILINDRO (ROSSO)	CYLINDER COVER (RED)
24C	4-403381	CARTER CILINDRO (BLU)	CYLINDER COVER (BLUE)
25	3015619	RONDELLA D. 24X45X4	WASHER D. 24X45X4
26	4-404566	TARGA S 53	S 53 LABEL
101	4210690	GUARNIZIONE PW 25	DUST COVER PW 25
102	4210691	GUARNIZIONE STELO	SHAFT GASKET
103	4-402870	TESTATA CILINDRO D. 50	CYLINDER RING NUT D. 50
104	4207934	GUARNIZIONE OR 3,53X42,86	O-RING 3,53X42,86
105	4-402872	CAMICIA CILINDRO D.50X273	CYLINDER CASING D. 50X273
106	4-402873	STELO CILINDRO D. 50X273	CYLINDER SHAFT D. 50X273
107	4210696	GUARNIZIONE OR 1,78X12,42	O-RING 1,78X12,42
108	4-402871	PISTONE CILINDRO D. 50	CYLINDER PISTON D. 50
109	4210698	GUARNIZIONE DAS 5034	GASKET DAS 5034
110	2200549	SET GUARNIZIONI CILINDRO D. 50	SET OF GASKETS FOR CYLINDER D. 50
111	2-71961	DADO AUTOBL. M 14X1,5	NUT M 14X1,5
112	2200508	CILINDRO D. 50X273 COMPLETO	COMPLETE CYLINDER D. 50X273
113	4-402879	STELO CILINDRO D. 50X900	CYLINDER SHAFT D. 50X900
114	4-402877	CAMICIA CILINDRO D. 50X900	CYLINDER CASING D. 50X900
115	5-490381	CILINDRO D. 50x900 COMPLETO	COMPLETE CYLINDER D. 50X900

Rif. Ref.	Codice Code	Descrizione	Description
116	3010110	PERNO FISSAGGIO CILINDRO LUNGO	LONG CYLINDER FIXING PIN
117	3010111	PERNO TRAINO CARRELLO	CARRIAGE TOW PIN
118	3010097	TUBO OLEODINAMICO L=1520	HYDRAULIC HOSE L=1520
119	4206347	BULLONE RACCORDO 1/4" FORATO	UNION 1/4" BOLT
120	4206391	RONDELLA RAME 1/4"	COPPER WASHER 1/4"
121	4-401564	TUBO OLEODINAMICO L=1820	HYDRAULIC HOSE L=1820
122	4206030	BULLONE RACCORDO 1/4" STROZZATO (D.1)	UNION 1/4" BOLT (D.1)
123	4210089	RACCORDO DIRITTO ESTREMITA' 1/4"	UNION 1/4"
124	4-404675	TUBO OLEODINAMICO L=147	HYDRAULIC HOSE L=147
125	4213989	NIPPLES CONGIUNZIONE 1/4"M. - 1/4"F.	NIPPLES 1/4"-1/4"
126	3-02269	VALVOLA A DOPPIO RITEGNO	NON-RETURN VALVE
127	4213988	OCCHIO FILETTATO 1/4"-1/4"	EYE JUNCTION 1/4"-1/4"
128	4-401566	TUBO OLEODINAMICO L=500	HYDRAULIC HOSE L=500
129	4206385	NIPPLES 1/4" - 1/4"	NIPPLES 1/4" - 1/4"
130	4219845	NIPPLES SPECIALE 1/4" - 1/4"	SPECIAL NIPPLES 1/4" - 1/4"
201	2-01273	VITE TSPEI M 10X20 10K	SOCKET COUNTERSUNK SCREW M 10X20
202	2-00663	DADO BASSO M 16	LOW NUT M 16
203	3306484	RULLO PEDANA	BOARD ROLLER
204	2-71925	VITE TE M 16X100 1/2 FIL.	HEXAGON HEAD CAP SCREW M 16X100
205	2200417	RULLO PEDANA CON VITE E DADO	ROLL WITH SCREW AND NUT
206	4-404248	SUPPORTO VASO GRASSO	TIRE PASTE CONTAINER SUPPORT
207	3010020	ASTA BRACCIO	ARM SHAFT
208	2-00152	DADO M 10	NUT M 10
209	2-01037	VITE TE M 10X30	HEXAGON HEAD CAP SCREW M 10X30
210A	2200509	PEDANA CON RULLI (GIALLO)	SLIDING TABLE WITH ROLLER (YELLOW)
210B	5-490431	PEDANA CON RULLI (ROSSO)	SLIDING TABLE WITH ROLLER (RED)
210C	5-490432	PEDANA CON RULLI (BLU)	SLIDING TABLE WITH ROLLER (BLUE)
211	3006653	TARGA CARRELLO	CARRIAGE LABEL
212	2-00113	DADO ALTO M 10	NUT M 10
213	2-00213	RONDELLA D. 10	WASHER FOR HEX CAP SCREW M 10
214	3007363	PATTINO CARRELLO	CARRIAGE SLIDING BLOCK
215	3307365	RASCHIATORE CARRELLO	CARRIAGE SCRAPER
216	2-71383	VITE TE M 10X40 1/2 FIL.	HEXAGON HEAD CAP SCREW M 10X40
217	2-00426	VITE TE M 10X70 1/2 FIL.	HEXAGON HEAD CAP SCREW M 10X70
218	3007768	SQUADRETTA FERMO VITE	SCREW STOP SQUARE
219A	5-490770	CARRELLO COMPLETO + TARGA (GIALLO)	COMPLETE CARRIAGE WITH LABEL (YELLOW)
219B	5-490771	CARRELLO COMPLETO + TARGA (ROSSO)	COMPLETE CARRIAGE WITH LABEL (RED)
219C	5-490772	CARRELLO COMPLETO + TARGA (BLU)	COMPLETE CARRIAGE WITH LABEL (BLUE)
301	2311723	UTENSILE	HEAD TOOL
302	3009491	FULCRO UTENSILE	HEAD TOOL FULCRUM
303	3005977	MOLLA D. 18X65X3,5	SPRING D. 18X65X3,5
304	2314279	MONOSTAFFA PORTA UTENSILI	TOOL HOLDER
305	2-71528	DADO AUTOBL. M 27X2	NUT WITH POLYAMIDE RING M 27X2
306	3014287	GANCIO MOLLA	SPRING HOOK
307	2-01194	DADO BASSO M 16X1,5	LOW NUT M 16X1,5
308	4210271	GUARNIZIONE OR 5,34X62,87	O-RING 5,34X62,87
309	3012063	RALLA D. 40X59,5X0,8	WASHER D. 40X59,5X0,8

Rif. Ref.	Codice Code	Descrizione	Description
310	3014286	PERNO DISCO STALLONATORE	HEAD TOOL FULCRUM PIN
311	2200667	DISCO STALLONATORE COMPLETO	COMPLETE BEAD BREAKER DISK
312	2200433	CHIAVISTELLO COMPLETO	COMPLETE LATCH
313	2-00983	SPINA EL. D. 6X20	SPRING PIN D. 6X20
314	3006289	LEVA CHIAVISTELLO	LATCH LEVER
315	3006285	BIELLA CHIAVISTELLO	LATCH CONNECTING ROD
316	3006286	CHIAVISTELLO	LATCH
317	2-71734	SPINA EL. D. 6X18	SPRING PIN D. 6X18
318	2-71733	SPINA EL. D. 10X20	SPRING PIN D. 10X20
319	3006288	MOLLA COMPRESSIONE	LATCH RETURNING SPRING
320	2-71928	SPINA EL. D. 8X32	SPRING PIN D. 8X32
321	2310261	UTENSILE COMPLETO	COMPLETE DOUBLE HEAD TOOL
322	3013871	NOTTOLINO ASTA	PAWL
323	2-00112	DADO ALTO M 8	NUT M 8
324	3013872	ASTA COMANDO SICURA	SHAFT FOR SAFETY DEVICE
325	4205821	FORCELLA CON PERNO	FORK WITH PIN
326	2-00111	DADO ALTO M 6	NUT M 6
327	2-00361	VITE TE M 6X16	HEXAGON HEAD CAP SCREW M 6X16
328	2-00656	DADO BASSO M 18X1,5	LOW NUT M 18X1,5
329	2-00896	RONDELLA D. 18	WASHER FOR HEX CAP SCREW M 18
330	3013868	MOLLA SICURA MECCANICA	SPRING FOR SAFETY DEVICE
331	2-00373	VITE TE M 8X20	HEXAGON HEAD CAP SCREW M 8X20
332	2-01299	ROSETTA D. 9X24X2	WASHER D. 9X24X2
333	3013867	BOCCOLA DISTANZIATRICE	SPACER
334	2-00362	VITE TE M 6X20	HEXAGON HEAD CAP SCREW M 6X20
335	4214064	TAPPO A LAMELLE D. 20	CAP D. 20
336	3013873	STAFFA SICURA MECCANICA	FLASK FOR SAFETY DEVICE
337	4-402637	TARGA PERICOLO	WARNING LABEL
338A	5-490773	BRACCIO PORTA UTENSILE + TARGA (GIALLO)	TOOL HOLDER ARM WITH LABEL (YELLOW)
338B	5-490774	BRACCIO PORTA UTENSILE + TARGA (ROSSO)	TOOL HOLDER ARM WITH LABEL (RED)
338C	5-490775	BRACCIO PORTA UTENSILE + TARGA (BLU)	TOOL HOLDER ARM WITH LABEL (BLUE)
339	2-01172	VITE TCEI M 8X130	SOCKET HEAD CAP SCREW M 8X130
340	3005916	MOLLA COMPRESSIONE	TOOL HOLDING ARM EJECTION SPRING
341	2110210	ESPULSORE BRACCIO	ARM EJECTOR
342	3005887	MOLLA TRAZIONE	TENSION SPRING
343	2-00412	VITE TE M 6X35 1/2 FIL.	HEXAGON HEAD CAP SCREW M 6X35
344	3007955	ECCENTRICO CRICCHETTO	RATCHET CAM
345	2410231	CRICCHETTO	RATCHET
346	3305242	IMPUGNATURA A SFERA	PLASTIC BALL KNOB
347	2-71878	VITE TE M 8X45 1/2 FIL.	HEXAGON HEAD CAP SCREW M 8X45
401	4209884	GUARNIZIONE OR 5,34X74,63	O-RING 5,34X74,63
402	3010250	FELTRO ANELLO L=330	RING FELT L=330
403	3010581	RASAMENTO D. 75X97,5X0,5	WASHER D. 75X97,5X0,5
404	3013373	ANELLO AUTOCENTRANTE	PROTECTION RING
405	3006372	LINGUETTA FORMA A 20X12X60	PARALLEL KEY 20X12X60
406	3011220	PROTEZIONE AUTOCENTRANTE	CHUCK COVER
407	4210241	GUARNIZIONE PW 35/G	GASKET PW 35/G

Rif. Ref.	Codice Code	Descrizione	Description
408	4300517	SEEGER INT. D. 45	SEEGER RING D. 45
409	2-01021	DADO AUTOBL. M 12	NUT WITH POLYAMIDE RING M 12
410	3009896	CROCE AUTOCENTRANTE	SELF-CENTERING CROSS
411	2-01130	ANELLO EL. D. 16	RETAINING RING FOR SHAFT D. 16
412	3009956	PERNO AUTOCENTRANTE	SELF-CENTERING PIN
413	2-01038	RONDELLA D. 20	WASHER FOR HEX CAP SCREW M 20
414	2-71527	DADO AUTOBL. M 20X1,5	SELF-LOCKING NUT M 20X1,5
415	3009892	BIELLA AUTOCENTRANTE	SELF-CENTERING CONNECTING ROD
416	2-01242	DADO AUTOBL. M 18X1,5	NUT WITH POLYAMID RING M 18X1,5
417	3006375	VITE SPECIALE M 12 LUNGA	LONG SPECIAL SCREW M 12
418	3006378	VITE SPECIALE M 18X1,5 LUNGA	LONG SPECIAL SCREW M 18X1,5
419	2200550	MANDRINO COMPLETO	COMPLETE SELF-CENTERING CHUCK
420	2409893	STABILIZZATORE	STABILIZER
421	3009891	SUPPORTO GRIFFA	CLAMP SUPPORT
422	3006012	GRIFFA	CLAMP
423	2-01191	VITE TCEI M 10X25 12K	SOCKET HEAD CAP SCREW M 10X25
424	3009954	VITE SPECIALE M 12	SPECIAL SCREW M 12
425	3006377	VITE SPECIALE M 18X1,5 MEDIA	AVERAGE SPECIAL SCREW M 18X1,5
426	3009957	BRACCIO DX	RIGHT ARM
427	3009905	BRACCIO SX	LEFT ARM
428	3009955	BOCCOLA BRACCIO	ARM BUSH
429	3-00623	BOCCOLA D. 35X30	BUSH D. 35X30
430	3010035	ASTA COMANDO MANDRINO	CHUCK CONTROL BAR
431	3009959	FLANGIA ANTERIORE CILINDRO D. 95	FRONT FLANGE FOR CYLINDER D. 95
432	4210118	GUARNIZIONE OR 5,34X91,44	O-RING 5,34X91,44
433	4210040	GUARNIZIONE OR 2,62X94,92	O-RING 2,62X94,92
434	4209724	GUARNIZIONE RS 3545	GASKET RS 3545
435	4210041	GUARNIZIONE OR 3,53X21,82	O-RING 3,53X21,82
436	4210042	GUARNIZIONE DAS 9575	GASKET DAS 9575
437	2200551	SET GUARNIZIONI CILINDRO D. 95	SET OF GASKETS FOR CYLINDER D. 95
438	3009958	PISTONE CILINDRO D. 95	PISTON FOR CILINDER D.9 5
439	2410033	CAMICIA CILINDRO D. 95	CASING FOR CYLINDER D. 95
440	4-401567	TUBO OLEODINAMICO L=1200	HYDRAULIC HOSE L=1200
441	4206390	GUARNIZIONE OR 3,53X23,4	O-RING 3,53X23,4
442	5-490779	PERNO RACCORDO GIREVOLE COMPLETO	COMPLETE REVOLVING UNION PIN
443	2-00863	VITE TCEI M 6X30	SOCKET HEAD CAP SCREW M 6X30
444	4210251	MANOMETRO D. 63	MANOMETER D. 63
445	2-02761	VITE TE M 6X14	HEXAGON HEAD CAP SCREW M 6X14
446	3016702	RONDELLA D. 6,25X35,5X5	WASHER D. 6,25X35,5X5
447	4207139	PROLUNGA 1/4"-1/4" MANOMETRO	EXTENSION 1/4"-1/4"
448	3008885	TARGA "MAX 130 BAR"	PRESSURE LABEL "MAX 130 BAR"
449	4221342	NIPPLES SPECIALE 1/4" M/F	SPECIAL NIPLES 1/4" M/F
450	5-490595	RACCORDO GIREVOLE COMPLETO	REVOLVING UNION COMPLETE
501A	4-404406	CARTER CILINDRO AUTOCENTRANTE (GIALLA)	CHUCK CYLINDER COVER (YELLOW)
501B	4-404826	CARTER CILINDRO AUTOCENTRANTE (ROSSO)	CHUCK CYLINDER COVER (RED)
501C	4-404829	CARTER CILINDRO AUTOCENTRANTE (BLU)	CHUCK CYLINDER COVER (BLUE)
502	4216752	SPIA LIVELLO OLIO	OIL FILLER WARNING LIGHT

Rif. Ref.	Codice Code	Descrizione	Description
503	2-00309	VITE TCEI M 6X16	SOCKET HEAD CAP SCREW M 6X16
504	3306135	TAPPO OLIO	OIL CAP
505	3006407	TARGA OLIO RIDUTTORE	GEARBOX LABEL
506A	5-490787	CARTER OLIO CON TAPPI (GIALLO)	GEARBOX COVER WITH PLUGS (YELLOW)
506B	5-490788	CARTER OLIO CON TAPPI (ROSSO)	GEARBOX COVER WITH PLUGS (RED)
506C	5-490789	CARTER OLIO CON TAPPI (BLU)	GEARBOX COVER WITH PLUGS (BLUE)
507	4-402636	TARGA PERICOLO	WARNING LABEL
508	3009931	RUOTA ELICOIDALE	HELICOIDAL GEAR
509	3009929	GUARNIZIONE RIDUTTORE	GASKET FOR GEARBOX
510A	3006017	PULEGGIA CONDOTTA (50HZ)	DRIVEN PULLEY (50HZ)
510B	3011564	PULEGGIA CONDOTTA (60HZ)	DRIVEN PULLEY (60HZ)
511	4-404886	CARTER CINGHIA	BELT COVER
512	2-00380	VITE TE M10X25	HEXAGON HEAD CAP SCREW M 10X25
513	3006359	RONDELLA D. 10,5X40X5	WASHER D. 10,5X40X5
514A	3-90025	CINGHIA TRAPEZOIDALE SPZ 800 (50HZ)	V-BELT SPZ 800 (50HZ)
514B	3-90007	CINGHIA TRAPEZOIDALE SPZ 812 (60HZ)	V-BELT SPZ 812 (60HZ)
515	4-404399	SUPPORTO MOTORE	MOTOR SUPPORT
516	2200797	TAPPO CARTER RIDUTTORE + OR	PLUG FOR GEARBOX COVER WITH OR
517	4205265	GUARNIZIONE OR 2,62X15,08	O-RING 2,62X15,08
518	2-01006	VITE TCEI M 6X8	SOCKET HEAD CAP SCREW M 6X8
519	4-404671	SCHERMO OLIO	OIL PROTECTION PLATE
520	2-03042	VITE TE M10X30 10K	HEXAGON HEAD CAP SCREW M 10X30
521	4220214	DISCO ELASTICO 10,2X22X1,25	SPECIAL WASHER 10,2X22X1,25
522	4-404690	SUPPORTO VITE SENZA FINE	WORM SCREW SUPPORT
523	3006384	DISTANZIALE D. 25,1X35X58	DRIVEN PULLEY SPACER D. 25,1X35X58
524A	3009923	CARTER POSTERIORE RIDUTTORE (GIALLO)	GEARBOX REAR COVER (YELLOW)
524B	4-402348	CARTER POSTERIORE RIDUTTORE (ROSSO)	GEARBOX REAR COVER (RED)
524C	4-403382	CARTER POSTERIORE RIDUTTORE (BLU)	GEARBOX REAR COVER (BLUE)
525	2-01257	DADO AUTOBL. M 6	NUT WITH POLYAMIDE RING M 6
526	3006360	RONDELLA PULEGGIA MOTRICE	DRIVING PULLEY WASHER
527	2-01034	CUSCINETTO RADIALE RIGIDO 25X52X15	BEARING 25X52X15
528	2-00716	LINGUETTA FORMA A 8X7X30	PARALLEL KEY 8X7X30
529	3009946	VITE SENZA FINE	WORM SCREW
530	4100007	CUSCINETTO 25X47X15	BEARING 25X47X15
531	3006379	DISTANZIALE CUSCINETTO	BEARING SPACER
532	3010253	RONDELLA D. 38X16,2X7	WASHER D. 38X16,2X7
533A	3006364	PULEGGIA MOTRICE (50HZ)	DRIVING PULLEY (50HZ)
533B	3011559	PULEGGIA MOTRICE (60HZ)	DRIVING PULLEY (60HZ)
534	2-01026	VITE TE M10X35 1/2 FIL.	SCREW M 10X35
535	3006363	DISTANZIALE CENTRAGGIO MOTORE	MOTOR CENTERING SPACER
536A	3-02412	MOTORE 230/400V 3PH 50HZ	MOTOR 230/400V 3PH 50HZ
536B	3-90008	MOTORE 230/400V 3PH 60HZ	MOTOR 230/400V 3PH 60HZ
536C	3-90010	MOTORE 230V 1PH 50HZ	MOTOR 230V 1PH 60HZ
536D	3-90009	MOTORE 230V 1PH 60HZ	MOTOR 230V 1PH 50HZ
537	4207431	PRESSACAVO PG16 + GHIERA	TIGHTNESS CABLE HOLDER PG16
601	3-02418	TRASFORMATORE	TRANSFORMER
602	3-02419	PORTAFUSIBILI 10X38	FUSE HOLDER 10X38

Rif. Ref.	Codice Code	Descrizione	Description
603	4-402353	TARGA PERICOLO TENSIONE	WARNING TENSION LABEL
604A	5-490790	INTERR. MAGNETOTERM. 4-6,3A (400V 3PH 50/60HZ)	SAFETY SWITCH 4-6,3A (400V 3PH 50/60HZ)
604B	5-490790	INTERR. MAGNETOTERM. 4-6,3A (230V 3PH 50/60HZ)	SAFETY SWITCH 4-6,3A (230V 3PH 50/60HZ)
604C	5-490792	INTERR. MAGNETOTERM. 9-14A (230V 1PH 50/60HZ)	SAFETY SWITCH 9-14A (230V 1PH 50/60HZ)
605A	5-490790	INTERR. MAGNETOTERM. 4-6,3A (400V 3PH 50/60HZ)	SAFETY SWITCH 4-6,3A (400V 3PH 50/60HZ)
605B	5-490791	INTERR. MAGNETOTERM. 6-10A (230V 3PH 50/60HZ)	SAFETY SWITCH 6-10A (230V 3PH 50/60HZ)
605C	5-490792	INTERR. MAGNETOTERM. 9-14A (230V 1PH 50/60HZ)	SAFETY SWITCH 9-14A (230V 1PH 50/60HZ)
606	2-71544	ROSETTA EL. D. 6	TOOTH WASHER D. 6
607	2-00359	VITE TE M 6X10	HEXAGON HEAD CAP SCREW M 6X10
608	4-405356	TAPPO	CAP
609	2117861	CAVO TERRA L=870	GROUND CABLE L=870
610	4219925	SPIA COMPLETA	COMPLETE LAMP
611A	5-490793	CONTATTORE 9A (50HZ)	CONTACTOR 9A (50HZ)
611B	5-490643	CONTATTORE 12A (60HZ)	CONTACTOR 12A (60HZ)
612	3-01807	LAMPADINA INNESTO BAIONETTA 30V 2W	LAMP 30V 2W
613	3-02196	INTERRUTTORE CON PROTEZIONE	MAIN SWITCH WITH PROTECTION
614	4-404994	SCHEDA ELETTRONICA	PRINTED CIRCUIT BOARD
615	3-02424	CHIAVE PER CASSETTA	BOX KEY
616	5-490639	SACCHETTO FUSIBILI	FUSES BAG
617	4-405000	CAVO PER ELETTROVALVOLE	ELECTRIC-VALVE CABLE
618A	4-404997	CAVO MOTORE CENTRALINA (3PH)	3 PH. HYDRAULIC SYSTEM MOTOR CABLE
618B	4-404998	CAVO MOTORE CENTRALINA (1PH)	1 PH. HYDRAULIC SYSTEM MOTOR CABLE
619A	4-404996	CAVO MOTORE AUTOCENTRANTE (3PH)	3 PH. CHUCK MOTOR CABLE
619B	4-404999	CAVO MOTORE AUTOCENTRANTE (1PH)	1 PH. CHUCK MOTOR CABLE
620A	4-404993	CAVO ALIMENTAZIONE (400V 3PH 50/60HZ)	FEEDING CABLE (400V 3PH 50/60HZ)
620B	4-404992	CAVO ALIMENTAZIONE (230V 3PH 50/60HZ)	FEEDING CABLE (230V 3PH 50/60HZ)
620C	4-404995	CAVO ALIMENTAZIONE (230V 1PH 50/60HZ)	FEEDING CABLE (230V 1PH 50/60HZ)
621A	5-490794	CENTRALINA ELETTRICA COMPL. (400V 3PH 50/60HZ)	COMPLETE ELECTRIC BOX (400V 3PH 50/60HZ)
621B	5-490795	CENTRALINA ELETTRICA COMPL. (230V 3PH 50/60HZ)	COMPLETE ELECTRIC BOX (230V 3PH 50/60HZ)
621C	5-490796	CENTRALINA ELETTRICA COMPL. (230V 1PH 50/60HZ)	COMPLETE ELECTRIC BOX (230V 1PH 50/60HZ)
701	4-401298	TARGA MOTORE	MOTOR LABEL
702A	3-01078	MOTORE CENTRALINA (230/400V 3PH 50HZ)	HYDRAULIC MOTOR (230/400V 3PH 50HZ)
702B	3-00888	MOTORE CENTRALINA (230/400V 3PH 60HZ)	HYDRAULIC MOTOR (230/400V 3PH 60HZ)
702C	4214178	MOTORE CENTRALINA (230V 1PH 50HZ)	HYDRAULIC MOTOR (230V 1PH 50HZ)
702D	4213708	MOTORE CENTRALINA (230V 1PH 60HZ)	HYDRAULIC MOTOR (230V 1PH 60HZ)
703	5-490587	SERIE GUARNIZIONI POMPA	SET OF PUMP GASKET
704	4-404440	PARAPOLVERE D. 12X22X7	GASKET D. 12X22X7
705	3-02378	GUARNIZIONE OR 107,2X5,34	O-RING 107,2X5,34
706	4211583	GUARNIZIONE OR 1,78X47,35	O-RING 1,78X47,35
707	5-490603	GUARNIZIONE POMPA COMPLETA	COMPLETE PUMP GASKET
708	2-00375	VITE TE M 8X30	HEXAGON HEAD CAP SCREW M 8X30
709	2-03529	VITE TCEI M 8X18	SOCKET HEAD CAP SCREW M 8X18
710	5-490580	FLANGIA MOTORE CON VITI	MOTOR FLANGE WITH SCREWS
711	2-00531	VITE STEI M 6X8 P. CON.	SOCKET SET SCREW M 6X8
712	5-490582	GIUNTO MOTORE	FLEXIBLE COUPLING
713	5-490623	FLANGIA POMPA CON GUARNIZIONI	PUMP FLANGE WITH GASKET
714	4-404291	VALVOLA DI RITEGNO	CHECK VALVE



Rif. Ref.	Codice Code	Descrizione	Description
715	4-404499	VALVOLA DI MASSIMA PRESSIONE	PRESSURE LIMIT VALVE
716	3-02414	GUARNIZIONE OR 2,62X9,19	O-RING 2,62X9,19
717	5-401115	BLOCCHETTO DI COLLEGAMENTO CON GUARNIZIONI	CONNECTING BLOCK WITH GASKETS
718	4-404438	FILTRO OLIO	OIL FILTER
719	2-00728	VTCEI M 6X14	SOCKET HEAD CAP SCREW M 6X14
720	2-00901	VITE TCEI M 8X50 1/2 FIL.	SOCKET HEAD CAP SCREW M 8X50
721	4-404541	BOBINA PER ELETTROVALVOLA	SOLENOID
722	4-404540	CARTUCCIA ELETTROVALVOLA ATTUATORE	CARTRIDGE VALVE
723	4-404539	CARTUCCIA ELETTROVALVOLA SELETORE	CARTRIDGE VALVE
724	5-490632	KIT GUARNIZIONI ELETTROVALVOLA	SET OF GASKETS FOR ELECTRIC-VALVE
725	5-401114	BLOCCO ELETTROVALVOLE COMPLETO	COMPLETE ELECTRIC-VALVE SUPPORT
726	2-03321	VITE TCEI M 8X65 1/2 FIL.	SOCKET HEAD CAP SCREW M8 X65
727	5-490585	POMPA 3,5 CC CON GUARNIZIONI	PUMP 3,5CC WITH GASKET
728	2-00363	VITE TE M 6X25	HEXAGON HEAD CAP SCREW M 6X25
729	4-404502	FILTRO OLIO COMPLETO L.157	COMPLETE OIL FILTER
730	2-01968	VITE TCEI M 8X85 1/2 FIL.	SOCKET HEAD CAP SCREW M 8X85
731	4-403961	SUPPORTO CENTRALINA ELETTRICA	ELECTRIC UNIT SUPPORT
732	2-00211	RONDELLA D. 6	WASHER FOR HEX CAP SCREW M 6
733	2-03523	TAPPO M 12X1,5	HEX. HEAD CAP SCREW M 12X1,5
734	2-03524	RONDELLA ALLUMINIO 12X18X1,5	ALUMINIUM WASHER 12X18X1,5
735	4-403825	GUARNIZIONE COLLETORE POMPA	PUMP GASKET
736	4-404468	ASTA LIVELLO OLIO	OIL LEVEL SHAFT
737	4213236	GUARNIZIONE OR 2,62X31,42	O-RING 31,42X2,62
738	4-403861	LAMIERA COPERCHIO CENTRALINA	TANK COVER
739	4-403858	GUARNIZIONE LAMIERA COPERCHIO	COVER GASKET
740	4-403943	SERBATOIO OLIO COMPLETO	COMPLETE OIL TANK
741	3006500	TARGA CENTRALINA OLEODINAMICA	LABEL FOR HYDRAULIC GEARBOX
742	4207031	TAPPO 1/2"	OIL OUT-LET CAP 1/2"
743	4207032	RONDELLA ALLUMINIO 1/2"	ALUMINIUM WASHER 1/2"
744	2-91766	VITE STEI M 6X35 P. PIANA	SOCKET SET SCREW M 6X35
745	2-00321	VITE TCEI M 8X25	SOCKET HEAD CAP SCREW M 8X25
746A	5-490780	CENTRALINA OLEODINAMICA 230/400V 3PH 50HZ	COMPLETE HYDRAULIC UNIT 230/400V 3PH 50HZ
746B	5-490781	CENTRALINA OLEODINAMICA 230/400V 3PH 60HZ	COMPLETE HYDRAULIC UNIT 230/400V 3PH 60HZ
746C	5-490782	CENTRALINA OLEODINAMICA 230V 1PH 50HZ	COMPLETE HYDRAULIC UNIT 230V 1PH 50HZ
746D	5-490783	CENTRALINA OLEODINAMICA 230V 1PH 60HZ	COMPLETE HYDRAULIC UNIT 230V 1PH 60HZ
801	4-401548	MANIGLIA	HANDLE
802	4-403487	CHIUSURA CASSETTA	BOX REAR PANEL
803	4-404360	CHIUSURA LATERALE CASSETTA	BOX SIDE LOCKING
804	2-00722	VITE TCIC M 6X45	CROSS PAN HEAD SCREW M 6X45
805	2-01979	DADO AUTOBL. BASSO M 6	LOW SELF-LOCKING NUT M 6
806	2-71516	DADO BASSO M 4	LOW NUT M 4
807	4-404359	CASSETTA COMANDO	MOBILE CONTROL BOX
808	4-400946	APPOGGIO LATERALE CONSOLLE	SIDE FLASK
809	2-02742	VITE AUTOF. D. 3,9X 9,5	SELF-TAPPING SCREW D. 3,9X9,5
810	4214397	COMMUTATORE A LEVETTA BIPOLARE	BIPOLAR SWITCH CHANGING POLE
811	2-00349	VITE TE M 4X12	HEXAGON HEAD CAP SCREW M 4X12
812	4-403541	TARGA APERTURA/CHIUSURA AUTOCENTRANTE	LABEL

Rif. Ref.	Codice Code	Descrizione	Description
813	4-403488	SUPPORTO INTERRUOTORE	HANDLE COVER
814	3007607	PROTEZIONE COMMUTATORE	PROTECTION FOR LEVER SWITCH
815	4-403489	PROTEZIONE INTERRUOTORE	CONTROL SWITCH COVER
816	2-71491	VITE AUTOF. D. 3,5X12,7	SELF-TAPPING SCREW D. 3,5X12,7
817	4-401030	SUPPORTO SELETORE	SELECTOR HOLDER
818	4-401031	PROTEZIONE MANIPOLATORE	HANDLE COVER
819	4-403542	TARGA MANIPOLATORI	LABEL
820	4-404524	MANIPOLATORE COMPLETO	COMPLETE CONTROL SWITCH LEVER
821	4-403485	CONSOLLE MOBILE	MOBILE CONTROL BODY
822	87290187	TAPPO A SCATTO D. 4,8	PLUG D. 4,8
823	3-02017	TAPPO A SCATTO D. 14,3	PLUG D. 14,3
824	2-00790	VITE TCIC M 4X10	CROSS PAN HEAD SCREW M 4X10
825	4-400950	PERNO ANTERIORE ROTAZIONE PEDALE	PEDAL ROTATION FRONT PIN
826	3308571	PEDALE A BILANCERE DX	RIGHT BALANCE PEDAL
827	3308572	PEDALE A BILANCERE SX	LEFT BALANCE PEDAL
828	2-00713	ROSETTA D. 5,5X15X1,6	WASHER D. 5,5X15X1,6
829	2-00891	VITE TCEI M 5X10	SOCKET HEAD CAP SCREW M 5X10
830	3006652	TARGA PEDALIERA E AUTOCENTRANTE	LABEL
831	4-400945	COPERCHIO PEDALIERA	PEDAL COVER
832	2-00155	DADO BASSO M 6	LOW NUT M6
833	2-00149	DADO M 4	NUT M 4
834	2-71541	ROSETTA EL. D. 4	TOOTH WASHER D. 4
835	3-01451	MICROINTERRUPTORE PEDALIERA	MICROSWICTH
836	355786	STAFFA PORTAMICRO	MICRO-SWITCH HOLDER FLASK
837	2-00575	VITE TCIC M 3X16	CROSS PAN HEAD SCREW M 3X16
838	2-71505	DADO ALTO M 3	NUT M 3
839	2-00150	DADO M 6	NUT M 6
840	4-400948	FERMO ROTAZIONE PEDALI	PEDAL ROTATION STOPPER
841	3013895	MOLLA SICURA MECCANICA	SPRING
842	317491	LEVA COMANDO MICRO	MICRO-SWITCH CONTROL LEVER
843	4-400949	DISTANZIALE ALBERO PEDALI	PEDAL PIN SPACER
844	2-00909	VITE TCEI M 6X35	SOCKET HEAD CAP SCREW M 6X35
845	4-405132	CAVO ESTERNO CONSOLLE	CONSOLLE EXTERNAL CABLE
846	5-490637	CONSOLLE COMANDI COMPLETA	COMPLETE MOBILE CONTROL DEVICE

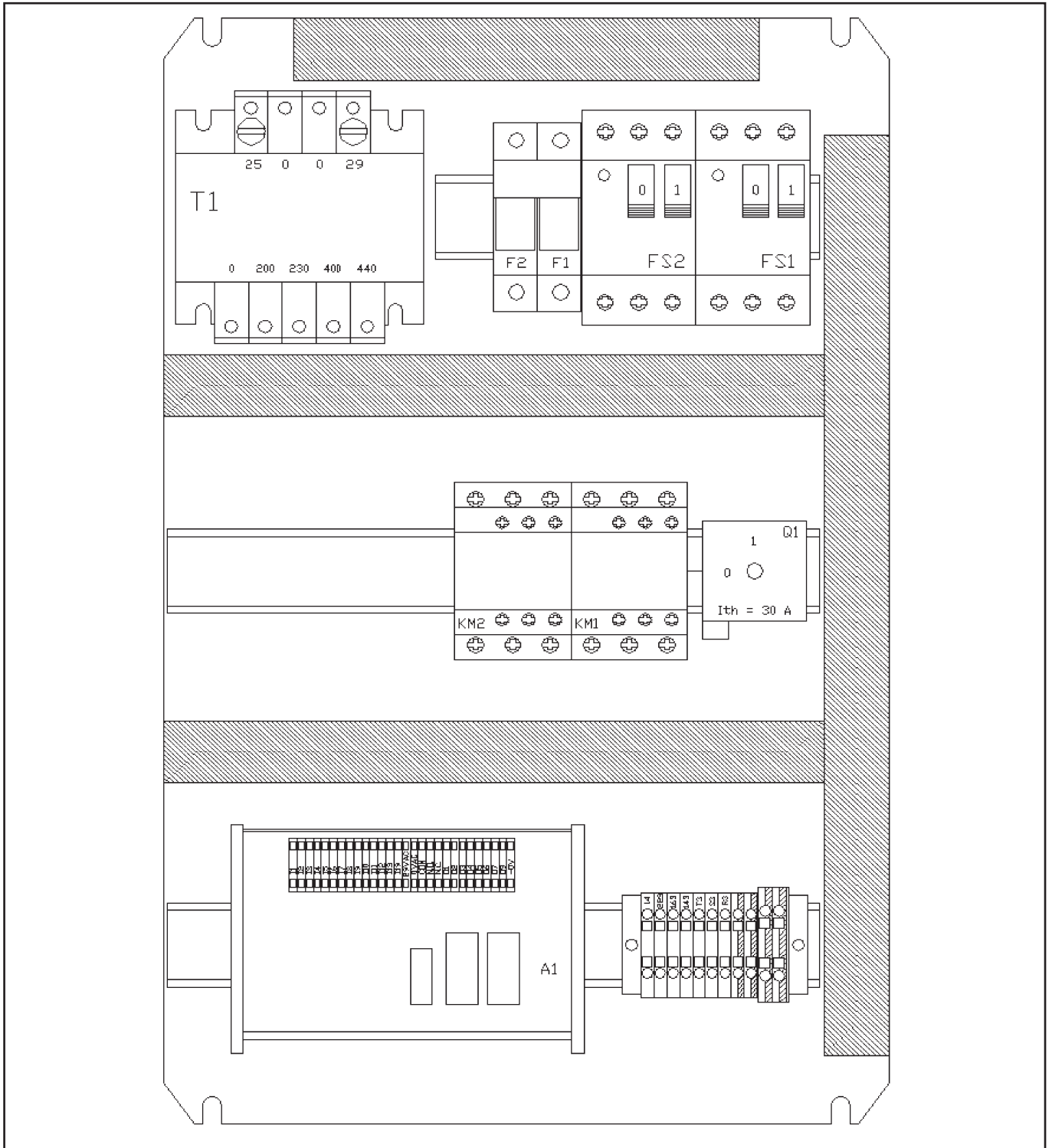

**TABELLA DI TARATURA**

Alimentazione Feeding	FS-1	FS-1	FS-2	FS-2
	Campo Range	Taratura Value	Campo Range	Taratura Value
400/3/50	4 - 6.3 A	5.2	4 - 6.3 A	4.1
415/3/50	4 - 6.3 A	5.0	4 - 6.3 A	4.0
440/3/50	4 - 6.3 A	4.6	4 - 6.3 A	3.7
200/3/50	6.3 - 10 A	9.3	6.3 - 10 A	7.1
230/3/50	6.3 - 10 A	8.2	4 - 6.3 A	5.3
240/3/50	6.3 - 10 A	7.9	4 - 6.3 A	5.1

**SAFETY SWITCH CALIBRATION**

Alimentazione Feeding	FS-1	FS-1	FS-2	FS-2
	Campo Range	Taratura Value	Campo Range	Taratura Value
400/3/60	4 - 6.3 A	5.8	4 - 6.3 A	4.1
415/3/60	4 - 6.3 A	5.6	4 - 6.3 A	4.0
440/3/60	4 - 6.3 A	5.2	4 - 6.3 A	4.1
200/3/60	6.3 - 10 A	9.3	6.3 - 10 A	7.1
230/3/60	6.3 - 10 A	9.3	4 - 6.3 A	6.3
240/3/60	6.3 - 10 A	8.9	4 - 6.3 A	6.3

# ELECTRIC DIAGRAM

# ELECTRIC DIAGRAM

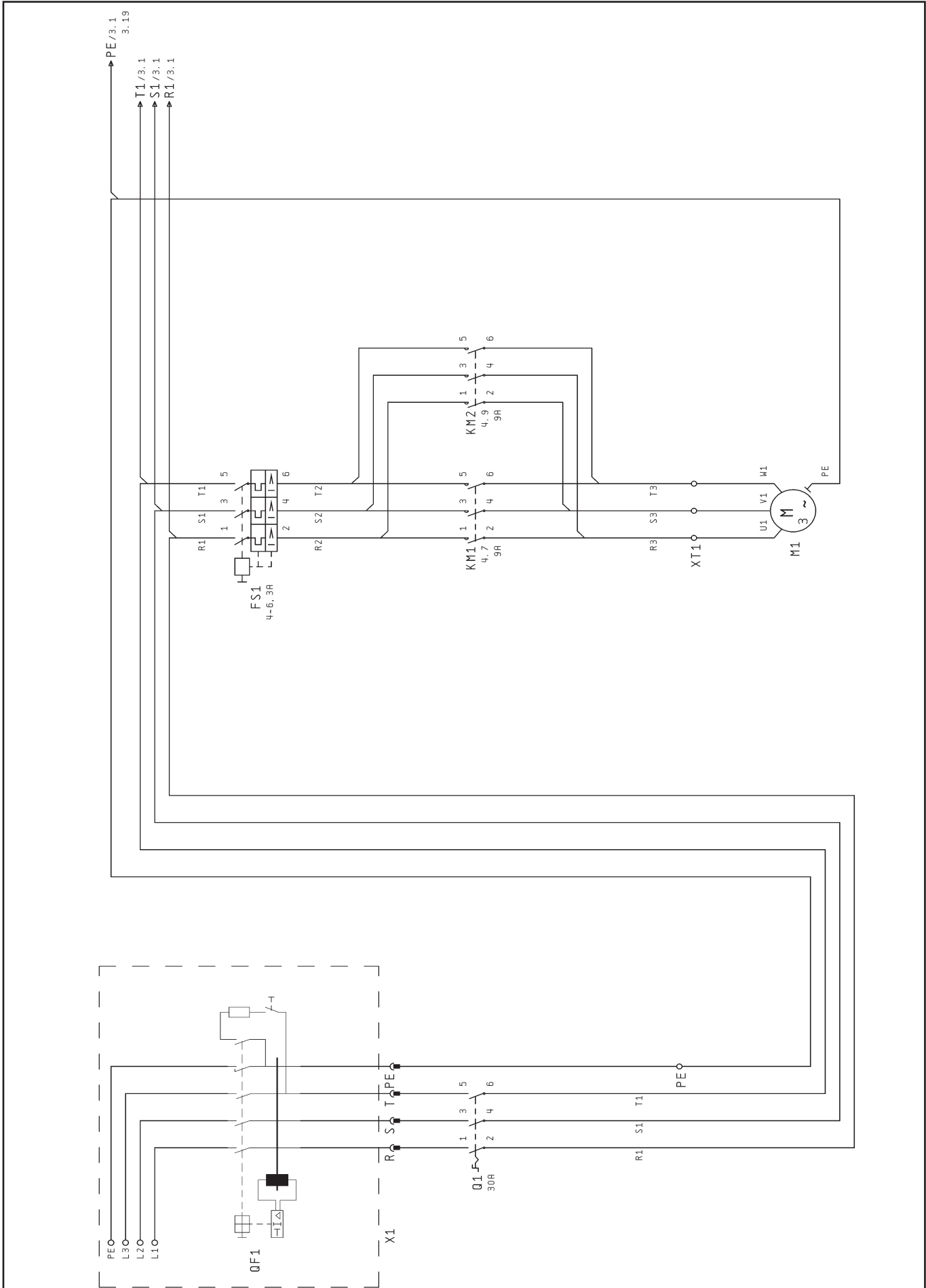

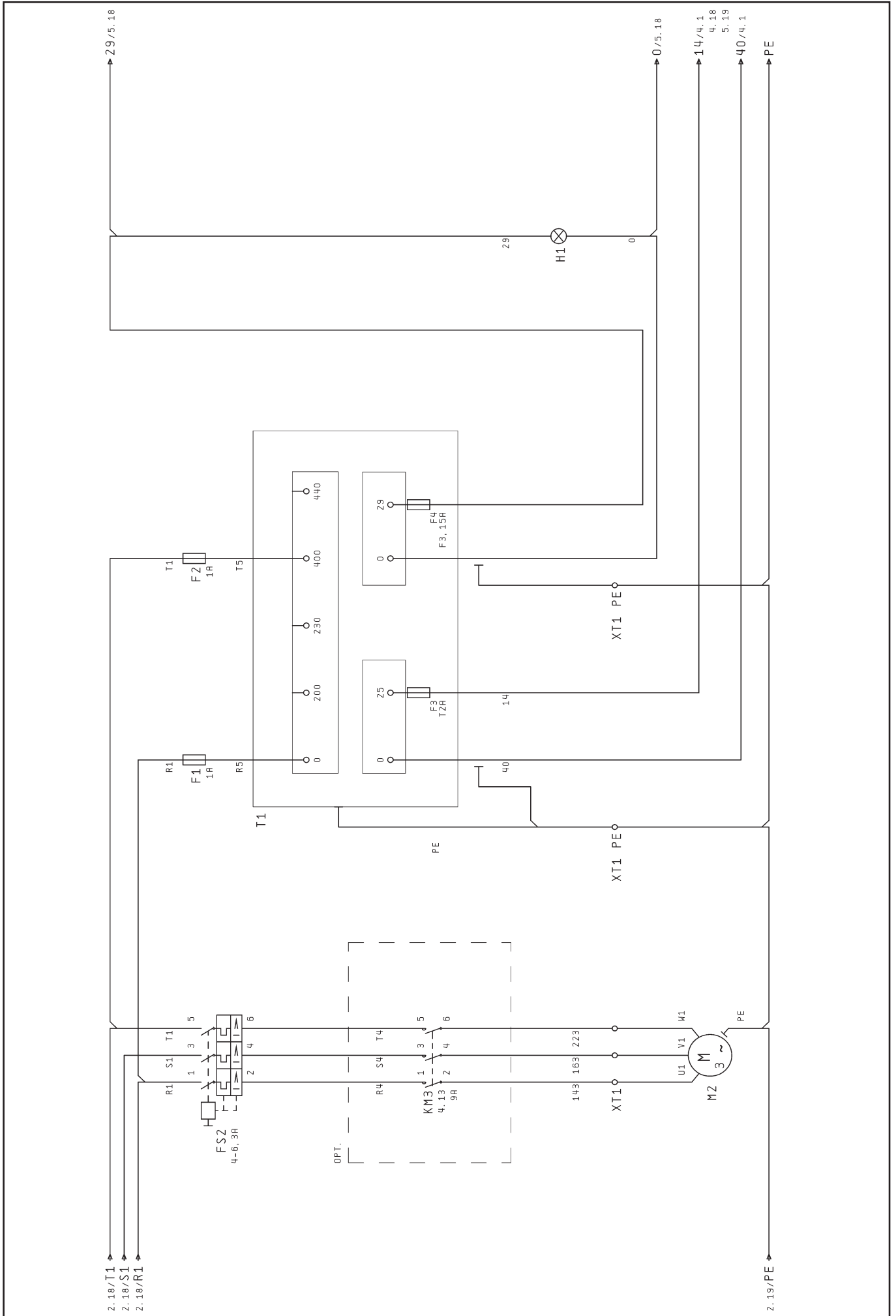

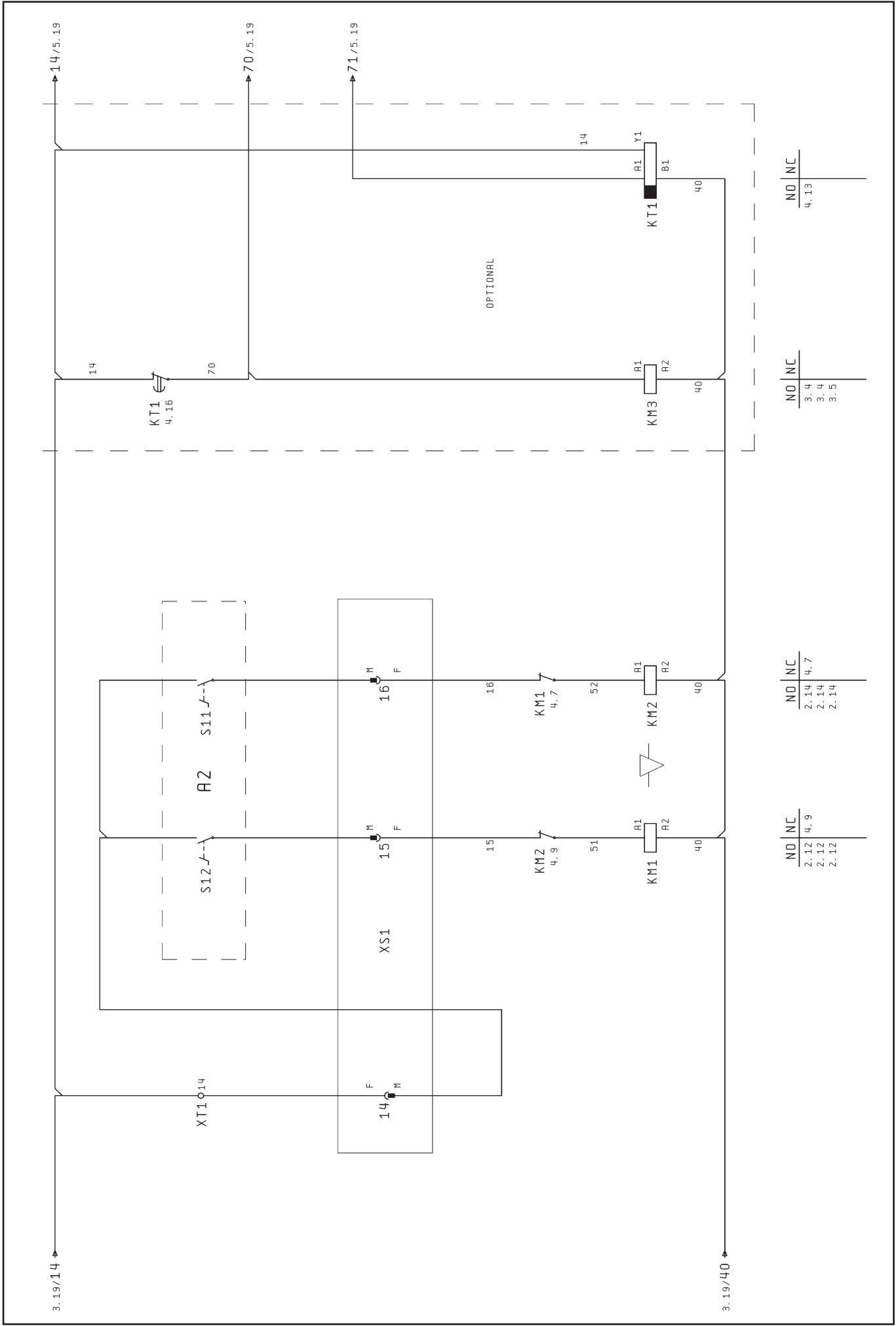

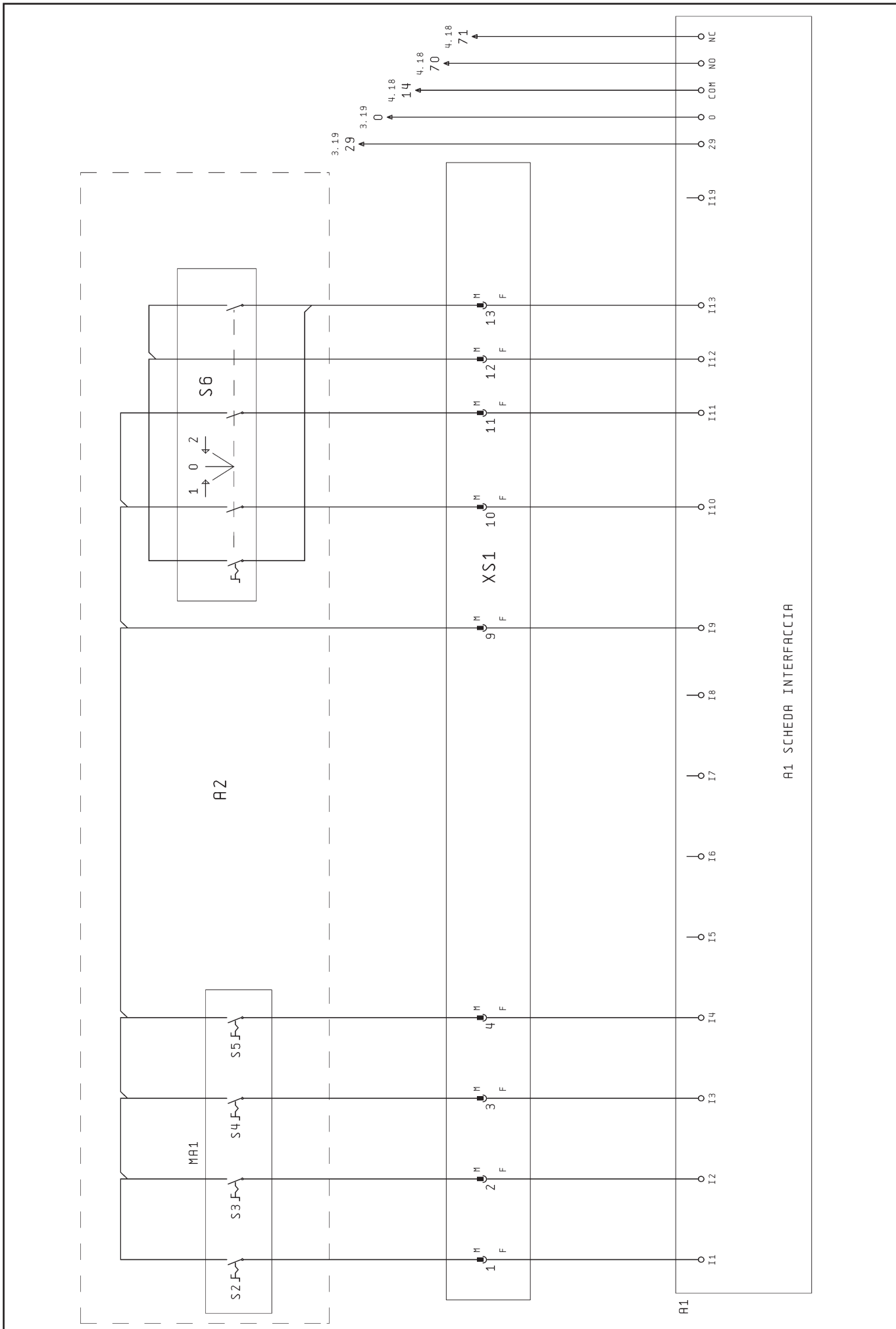

A1 SCHEDA INTERFACCIA

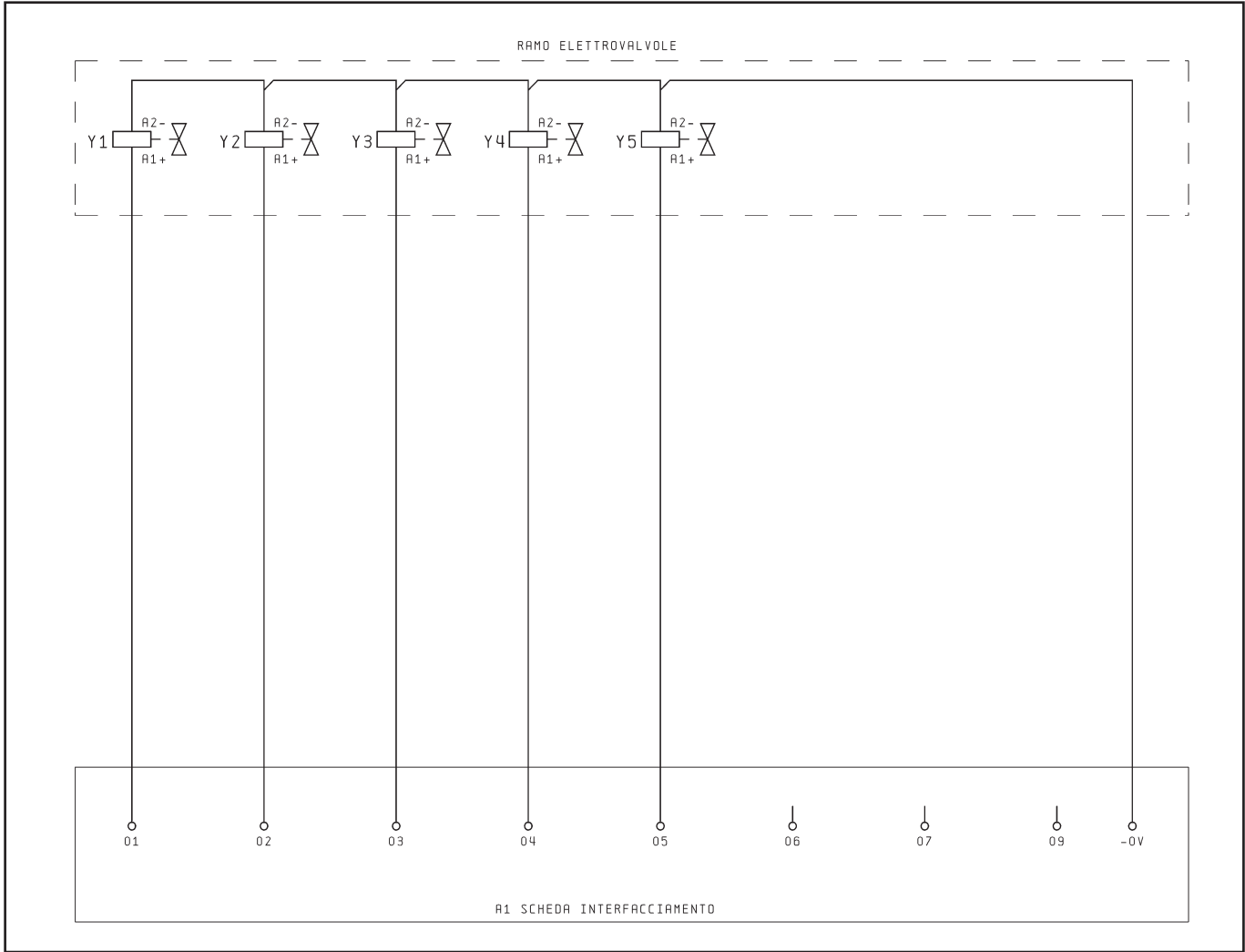



Interruttore differenziale (a carico dell'utilizzatore)	QF1	Differential switch (user installation)
Preso allacciamento macchina	X1	Feeding socket
Sezionatore principale blocco porta	Q1	Main control switch
Magnetotermico motore autocentrante	FS1	Chuck motor safety switch
Motore autocentrante	M1	Chuck motor
Magnetotermico motore centralina oleodinamica	FS2	Hydraulic system motor safety switch
Motore centralina oleodinamica	M2	Hydraulic system motor
Trasformatore	T1	Transformer
Lampada spia rete	H1	Feeding warning light
Marcia oraria autocentrante	KM1	Clockwise chuck rotation contactor
Marcia antioraria autocentrante	KM2	Anti-clockwise chuck rotation contactor
Teleruttore centralina oleodinamica (optional)	KM3	Hydraulic box contactor (optional)
Scheda interfaccia pedaliera	A1	Mobile control system PCB
Pedaliera di comando	A2	Mobile control system
Comando rotazione antioraria autocentrante	S12	Anti-clockwise chuck rotation control
Comando rotazione oraria autocentrante	S11	Clockwise chuck rotation control
Salita braccio	S2	Arm lifting microswitch
Discesa braccio	S3	Arm lowering microswitch
Apertura carrello	S4	Carriage opening microswitch
Chiusura carrello	S5	Carriage closing microswitch
Connettore 25 poli F/M	XS1	25 poles M/F connector
Switch comando chiusura apertura autocentrante	S6	Chuck opening/closing microswitch
Fusibile 1A	F1 - F2	Fuse 1A
Fusibile 2AT	F3	Fuse 2AT
Fusibile 3,15A	F4	Fuse 3,15A
Temporizzatore (optional)	KT1	Timer (optional)

# SCHEMA OLEODINAMICO

# OLEODINAMIC SCHEME

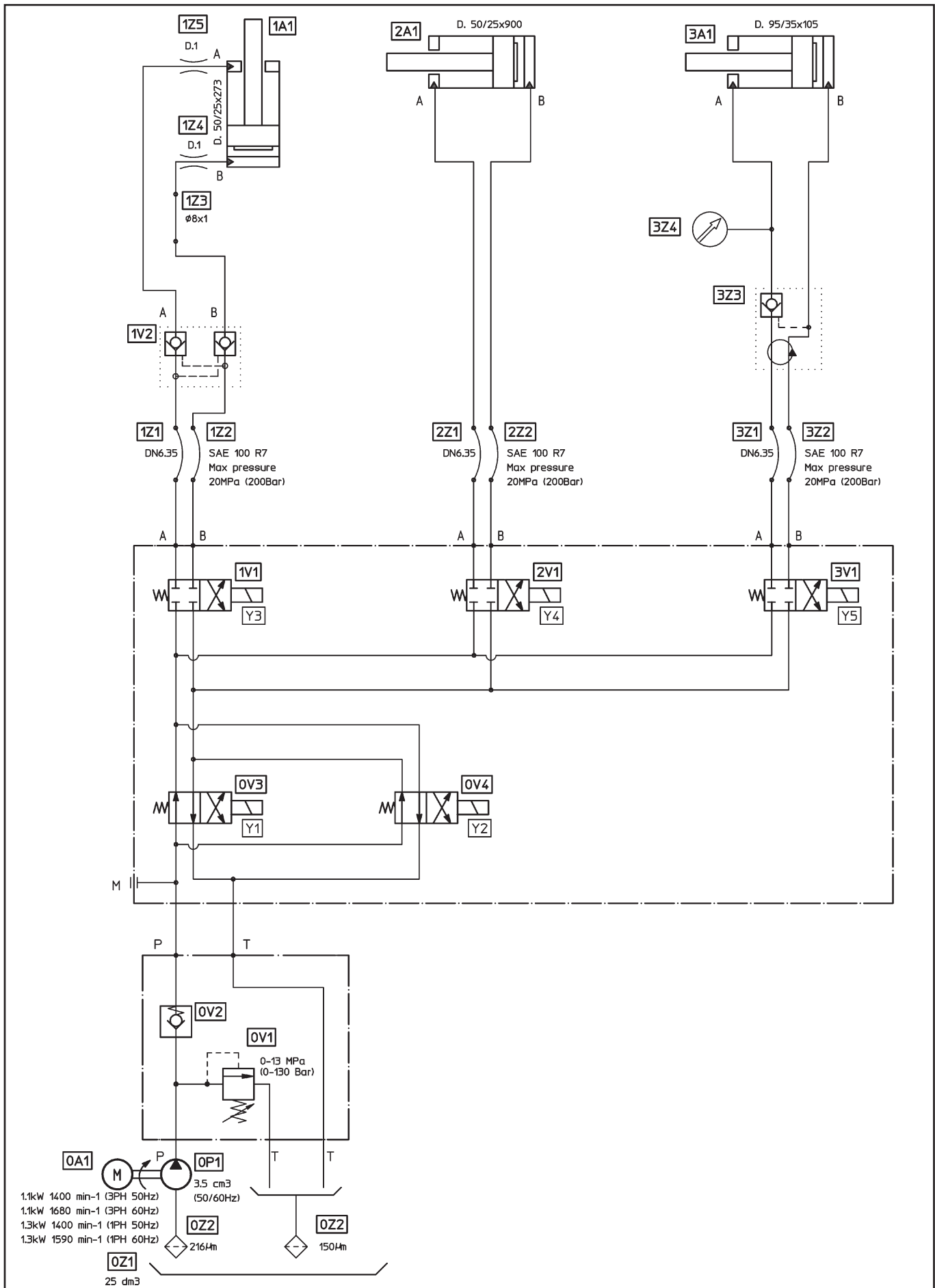

Motore centralina oleodinamica	<b>0A1</b>	<i>Hydraulic gearbox motor</i>
Pompa ad ingranaggi	<b>0P1</b>	<i>Pump with gears</i>
Valvola limitatrice di pressione	<b>0V1</b>	<i>Pressure limit valve</i>
Valvola unidirezionale	<b>0V2</b>	<i>Unidirectional valve</i>
Elettrovalvola selezione circuito	<b>0V3</b>	<i>Circuit selection electric-valve</i>
Elettrovalvola selezione circuito	<b>0V4</b>	<i>Circuit selection electric-valve</i>
Serbatoio centralina	<b>0Z1</b>	<i>Oil tank</i>
Filtro aspirazione	<b>0Z2</b>	<i>Suction filter</i>
Filtro scarico	<b>0Z3</b>	<i>Discharge filter</i>
Cilindro braccio autocentrante	<b>1A1</b>	<i>Self-centering arm cylinder</i>
Elettrovalvola comando cilindro	<b>1V1</b>	<i>Cylinder control electric-valve</i>
Valvola di ritegno	<b>1V2</b>	<i>Non-return valve</i>
Tubo flessibile	<b>1Z1</b>	<i>Flexible hose</i>
Tubo flessibile	<b>1Z2</b>	<i>Flexible hose</i>
Tubo rigido	<b>1Z3</b>	<i>Rigid hose</i>
Strozzatura fissa	<b>1Z4</b>	<i>Fix choke</i>
Strozzatura fissa	<b>1Z5</b>	<i>Fix choke</i>
Cilindro carrello	<b>2A1</b>	<i>Carriage cylinder</i>
Elettrovalvola comando cilindro	<b>2V1</b>	<i>Cylinder control electric-valve</i>
Tubo flessibile	<b>2Z1</b>	<i>Flexible hose</i>
Tubo flessibile	<b>2Z2</b>	<i>Flexible hose</i>
Cilindro autocentrante	<b>3A1</b>	<i>Self-centering chuck cylinder</i>
Elettrovalvola comando cilindro	<b>3V1</b>	<i>Cylinder control electric-valve</i>
Tubo flessibile	<b>3Z1</b>	<i>Flexible hose</i>
Tubo flessibile	<b>3Z2</b>	<i>Flexible hose</i>
Raccordo girevole completo	<b>3Z3</b>	<i>Rotating union assembly</i>
Manometro	<b>3Z4</b>	<i>Pressure gauge</i>



**SICE**  
AUTOMOTIVE EQUIPMENT

**SOCIETA' ITALIANA COSTRUZIONI ELETTRMECCANICHE S.I.C.E. - S.p.A.**  
**Via Modena, 34 - 42015 CORREGGIO (R.E.) - ITALY**

Tel. (0522) 693640  
Fax (0522) 642882  
E-mail: [sice@sice.it](mailto:sice@sice.it)

Export dept.:  
Tel. (059) 348611  
Fax (059) 359358  
E-mail: [sice@planeta.it](mailto:sice@planeta.it)

Tel. (059) 348611  
Fax (059) 359358  
E-mail: [sice@planeta.it](mailto:sice@planeta.it)