

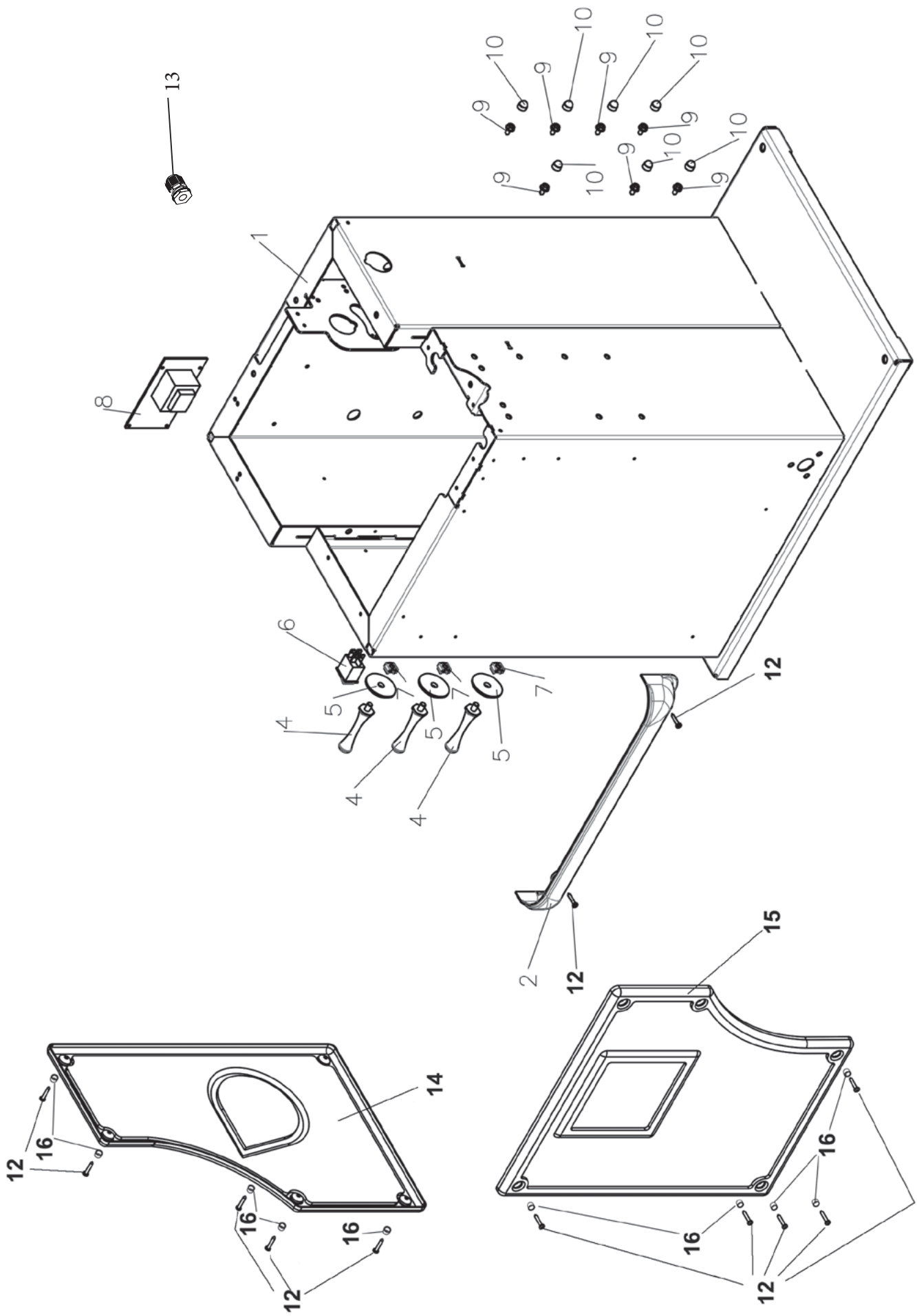

5800

**Esplso con elenco ricambi
Exploded view with spare parts list**





Rif. Ref.	Codice Code	Descrizione Articolo	Description	Description	Description	Beschreibung
1	5841818	CARCASSA COMPL. S800 - GRIGIO 7040	MACHINE FRAME S800 - GREY 7040		CHASSIS S800 - GRIS 7040	MASCHINENRAHMEN S800 - GRAU 7040
2	3040663	COPERTURA ANTERIORE ABS S800	S800 ABS FRONT COVER		COUVERTURE AVANT ABS S800	S800 ABS VORDERE ABDECKUNG
4	3036383	PERNO PORTA CONO - PLASTIFICATO NERO	CONE HOLDER - PLASTICIZED BLACK		AXE PORTE CONE - PLASTIFIE' NOIR	KEGELHALTER - PLASTIK-SCHWARZ
5	3040636	DISCO PER PERNO PORTA CONO	DISC FOR CONE HOLDER		DISQUE POUR AXE PORTE-CONE	SCHEIBE FÜR KEGELHALTER
6	4592498	INTERRUTTORE BASCULANTE S800	SWITCH ON-OFF		INTERRUPTEUR	SCHALTER
7	4394168	DADO GABBIA M8 ZNT (1,8 - 3,2) (K)	NUT M8 (1,8 - 3,2)		ECROU M8 (1,8 - 3,2)	MUTTER M8 (1,8 - 3,2)
8	4592517	SCHEDA POTENZA S800	POWER BOARD		CARTE DE PUISSANCE	LEISTUNGSKARTE
9	4393123	VITE AUTOF. TE 6,3x13 ZNT (Bianca)	SELF-TAPPING SCREW TE 6,3x13 ZNT BLACK DIN6946		VIS AUTOTARAUDEUSE TE 6,3x13 ZNT NOIR DIN6946	BLECHSCHRAUBE TE 6,3x13 ZNT SCHWARZ DIN6946
10	4293083	COPRIDADO CH 10	NUT COVER		COUVRE-ECROU	MUTTER ABDECKUNG
12	4393122	VITE AUTOPERF. TC+ 4x25 ZNT (4,2 X 25) ZNT (K)	SELF-TAPPING SCREW TC+ 4x25 (4,2 X 25) ZNT BLACK		VIS AUTOTARAUDEUSE TC+ 4x25 (4,2 X 25) ZNT NOIR	SELBSTSCHNEIDENDE SCHRAUBE TC+ 4x25 (4,2 X 25) ZNT SCHWARZ
13	4598092	PRESSACAVO BIMED BB04 PG13,5 + GHIERA *	CABLE FASTENER		PRESSE-CABLE	KABELDURCHGANG
14	3036131	PANNELLO LATERALE ABS - BLU	ABS SIDE PANEL - BLUE		PANNEAU LATERAL ABS - BLEU	ABS SEITENPANEEL - BLAU
15	3036132	PANNELLO ANTERIORE ABS - BLU	ABS FRONT PANEL - BLUE		PANNEAU AVANT EN ABS - BLEU	ABS VORDERPLATTE - BLAU
16	4292557	BOCCOLA PER POMELLO D.3 13x10	BUSHING D.3 13X10			BÜCHSE D.3 13X10

DA MATRICOLA : 22181900020
FROM SERIAL NUMBER: 22181900020

A = 115V VERSION

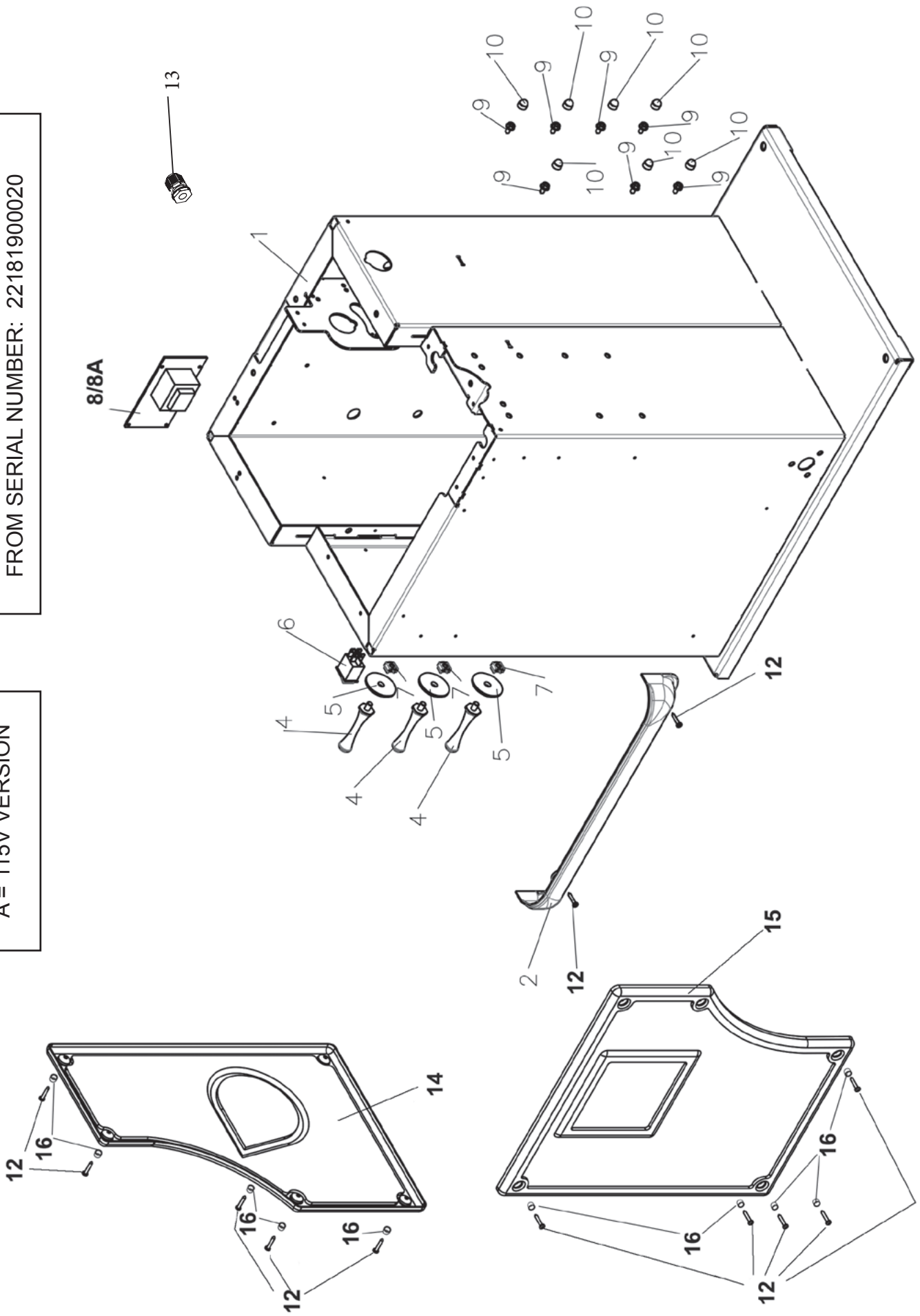

Rif. Ref.	Codice Code	Descrizione Articolo	Description	Description	Description	Beschreibung
1	5841818	CARCASSA COMPL. S800 - GRIGIO 7040	MACHINE FRAME S800 - GREY 7040	MACHINE FRAME S800 - GREY 7040	CHASSIS S800 - GRIS 7040	MASCHINENRAHMEN S800 - GRAU 7040
2	3040663	COPERTURA ANTERIORE ABS S800	S800 ABS FRONT COVER	S800 ABS FRONT COVER	COUVERTURE AVANT ABS S800	S800 ABS VORDERE ABDECKUNG
4	3036383	PERNO PORTA CONO - PLASTIFICATO NERO	CONE HOLDER - PLASTICIZED BLACK	CONE HOLDER - PLASTICIZED BLACK	AXE PORTE CONE - PLASTIFIE' NOIR	KEGELHALTER - PLASTIK-SCHWARZ
5	3040636	DISCO PER PERNO PORTA CONO	DISC FOR CONE HOLDER	DISC FOR CONE HOLDER	DISQUE POUR AXE PORTE-CONE	SCHEIBE FÜR KEGELHALTER
6	4592498	INTERRUTTORE BASCULANTE S800	SWITCH ON-OFF	SWITCH ON-OFF	INTERRUPTEUR	SCHALTER
7	4394168	DADO GABBIA M8 ZNT (1,8 - 3,2) (K)	NUT M8 (1,8 - 3,2)	NUT M8 (1,8 - 3,2)	ECROU M8 (1,8 - 3,2)	MUTTER M8 (1,8 - 3,2)
8	4591930	SCHEDA POTENZA S800 1PH 230V "SLL"	POWER BOARD S800 1PH 230V "SLL"	POWER BOARD S800 1PH 230V "SLL"	CARTE DE PUISSANCE S800 1PH 230V "SLL"	LEISTUNGSPLATINE S800 1PH 230V "SLL"
8A	4591929	SCHEDA POTENZA S800 1PH 115V "SLL"	POWER BOARD S800 1PH 115V "SLL"	POWER BOARD S800 1PH 115V "SLL"	CARTE PUISSANCE S800 1PH 115V "SLL"	SCHEDA POTENZA S800 1PH 115V "SLL"
9	4393123	VITE AUTOF. TE 6,3x13 ZNT (Bianca)	SELF-TAPPING SCREW TE 6,3x13 ZNT BLACK DIN6946	SELF-TAPPING SCREW TE 6,3x13 ZNT BLACK DIN6946	VIS AUTOTARAUDEUSE TE 6,3x13 ZNT NOIR DIN6946	BLECHSCHRAUBE TE 6,3x13 ZNT SCHWARZ DIN6946
10	4293083	COPRIDADO CH 10	NUT COVER	NUT COVER	COUVRE-ECROU	MUTTER ABDECKUNG
12	4393122	VITE AUTOPERF. TC+ 4x25 ZNT (4,2 X 25) ZNT (K)	SELF-TAPPING SCREW TC+ 4x25 (4,2 X 25) ZNT BLACK	SELF-TAPPING SCREW TC+ 4x25 (4,2 X 25) ZNT BLACK	VIS AUTOTARAUDEUSE TC+ 4x25 (4,2 X 25) ZNT NOIR	SELBSTSCHNEIDENDE SCHRAUBE TC+ 4x25 (4,2 X 25) ZNT SCHWARZ
13	4598092	PRESSACAVO BIMED BB04 PG13,5 + GHIERA *	CABLE FASTENER	CABLE FASTENER	PRESSE-CABLE	KABELDURCHGANG
14	3036131	PANNELLO LATERALE ABS - BLU	ABS SIDE PANEL - BLUE	ABS SIDE PANEL - BLUE	PANNEAU LATERAL ABS - BLEU	ABS SEITENPANEEL - BLAU
15	3036132	PANNELLO ANTERIORE ABS - BLU	ABS FRONT PANEL - BLUE	ABS FRONT PANEL - BLUE	PANNEAU AVANT EN ABS - BLEU	ABS VORDERPLATTE - BLAU
16	4292557	BOCCOLA PER POMELLO D.3 13x10	BUSHING D.3 13X10	BUSHING D.3 13X10		BÜCHSE D.3 13X10

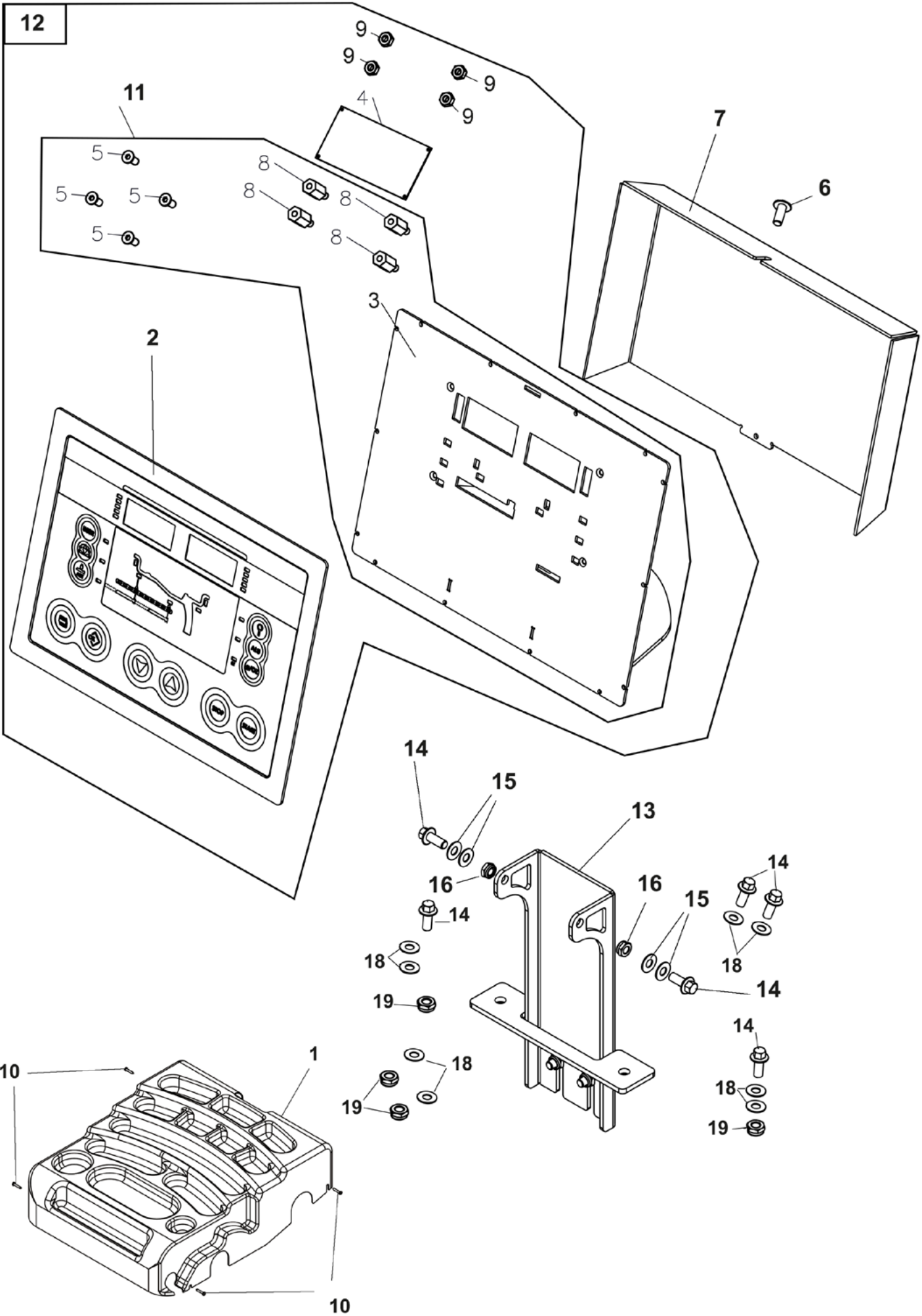

Rif. Ref.	Codice Code	Descrizione Articolo	Description	Description	Beschreibung
1	3039965	COPERTURA PORTAPESI ABS S800	WEIGHTS HOLDER ABS COVER	COUVERTURE EN ABS POUR TABLETTE A POIDS	ABS-DECKUNG FÜR GEWICHT-ENAUFNHME
2	3035895	TASTIERA EQUILIBRATRICE S820	KEYBOARD - BALANCER S820	CLAVIER - EQUILIBREUSE S820	TASTATUR - WUCHTMASCHINE S820
3	6635205	FLANGIA DISPLAY LED COMPL. - NERO	LED DISPLAY FLANGE COMPL. - BLACK	BRIDE AFFICHEUR LED COMPL. - NOIR	FLANSCH FÜR LED-ANZEIGE KOM-PL. - SCHWARZ
4	4591928	SCHEDELA ELABORATORE S800 "SLL"	COMPUTER BOARD S800 "SLL"	CARTE ELABORATEUR S800 "SLL"	COMPUTER-PLATINE S800 "SLL"
5	4396602	VITE TSPEI M 3x8 10.9 ZNT 5933	SCREW TSPEI 3x8 10.9 ZNT 5933	VIS 3x8	SCHRAUBE 3x8
6	4392120	VITE TBEI M 6x14 BRUNITA 10.9	SCREW	VIS	SCHRAUBE
7	6635067	COPERCHIO DISPLAY LED - NERO	LED DISPLAY COVER - BLACK	COUVERCLE AFFICHEUR LED - NOIR	DECKEL FÜR LED-ANZEIGE - SCHWARZ
8	4393130	DISTANZIALE MF IN ACCIAIO M3X8	STELL SPACER M3X8	ENTRETOISE MF EN ACIER M3X8	STAHL DISTANZSTÜCK M3X8
9	4399127	DADO M 3 6S ZNT 5588 (K)	NUT M3	ECROU M3	MUTTER M3
10	4393123	VITE AUTOF. TE 6,3x13 ZNT (Bianca)	SELF-TAPPING SCREW TE 6,3x13 ZNT BLACK DIN6946	VIS AUTOTARADEUSE TE 6,3x13 ZNT NOIR DIN6946	BLECHSCHRAUBE TE 6,3x13 ZNT SCHWARZ DIN6946
11	2044400	GR. FLANGIA CON VITI	FLANGE WITH SCREWS	BRIDE AVEC VIS	FLANSCH MIT SCHRAUBEN
12	2044401	GR. PANNELLO + SCHEDELA + TASTIERA	PANEL + BOARD + KEYBOARD	PANNEAU + CARTE + CLAVIER	PANEEL + PLATINE + TASTATUR
13	6641960	SUPPORTO MONITOR SALDATO VERN - NERO B.	MONITOR SUPPORT	SUPPORT MONITEUR	MONITOR-UNTERSTÜTZUNG
14	4399827	VITE TE 8x20 8.8 ZNT 5739 (K)	SCREW 8x20	VIS 8x20	SCHRAUBE 8X20
15	4399894	MOLLA TAZZA 8,2X18X1 UNI 8737 - DIN 2093 (*) (K)	BELLEVILLE WASHER 8,2x18x1	RESSORT 8,2x18x1	FEDER 8,2x18x1
16	4399900	DADO AUTOBL.M 8 BASSO 6.S 7474 (K)	SELF-LOCKING NUT M8-LOW.6S. 7474	ECROU DE VERROUILLAGE M8	SELBSTSPERRENDE MUTTER M8
18	4399829	RONDELLA 8 (8,4x16x1,5) ZNT6592 (K)	WASHER 8 (8,4x16x1,5)	RONDELLE 8 (8,4X16X1,5)	UNTERLEGSSCHEIBE 8 (8,4x16x1,5)
19	4399976	DADO M 8 6S ZNT 5588 (K)	NUT M8	ECROU M8	MUTTER M8

1	7041845	SCATOLA PIEZO FRENO	PIEZO BOX
2	2141945	LEVA PORTA FRENO COMPLETA	LEVER
3	4398783	SPINA ELASTICA D.4x24	ELASTIC PIN D.4x24
4	4292491	MOLLA 2x16x21 COD, B/1355	SPRING
5	4399971	DADO AUTOBL. M10 BASSO	SELF-LOCKING NUT M10
6	4399378	RONDELLA 10 (10.5x21x2)	WASHER 10 (10.5x21x2)
7	3040625	AMMORTIZZATORE LEVA PORTAFRENO	SHOCK ABSORBER
8	3041982	MOLLA DATORE DI FASE	PICK UP BOARD SPRING
9	4393123	VITE FLANG. AUTOF. TE 6.3x13	SCREW SELF-THEADING TE 6.3x13
10	4592434	MOTORE 0.12KW 1PH 230V 4 POLI	MOTOR
11	4399946	VITE TE 8x16	SCREW 8x16
12	4399829	RONDELLA 8 (8.4x16x1.5)	WASHER 8 (8.4x16x1.5)
13	3043330	PANTOGRAFATO ATTACCO MOTORE	MOTORE MOUNTING BRACKET
14	4392535	VITE FLANG. TENSOLock TE M5x10	SCREW 5x10
15	4292505	CINGHIA POLY-V TB2/7x480	BELT
17	3040568	DADO BLOC. CONT. PULEGGIA	NUT FOR PULLEY
18	3038501	PULEGGIA	PULLEY
19	4399801	ANELLO SEEGER E D.25	SEEGER RING D.25
20	4399814	ANELLO SEEGER I D.47	SEEGER RING D.47
21	4296688	CUSCINETTO 6005-2Z 25/47/12	BEARING
22	4399976	RONDELLA 8 (9x24x2)	WASHER 8 (9x24x2)
23	4399863	DADO M8 6S	NUT M8
24	4393124	VITE FLANG. TE M8x20	SCREW 8x20
25	2143186	GRUPPO LAMINE COMPLETO	EDGES GROUP
26	7039924	GRUPPO ALBERO COMPLETO D40	COMPL. SHAFT
27	3040602	MOLLA COMP. GRUPPO DI LANCIO	SPRING
28	3038502	COPERCHIO PER MOLLA	SPRING COVER
29	4392506	ANELLO D'ARRESTO SB118	STOP RING
30	3039927	TERMINALE FILETTATO D.40	THREADED END
31	4393066	RONDELA SCHONORR MM10	KNURLED LOCK WASHER 10.5x16x1
32	4393070	VITE TCEI M10x160 8.8 P.F.	SCREW TCEI M10x160
33	4399969	DADO M10 6S ALTO	NUT M10
34	4398944	MOLLA A TAZZA 12.2x25x1.5	BELLEVILLE WASHER 12.2x25x1.5
35	4398944	RONDELLA 10 (11x30x2.5) 6593-C	WASHER 10 (11x30x2.5)
36	2041803	PIEZO DINAMICO	DINAMIC PIEZO
37	2041802	PIEZO STATICO	STATIC PIEZO
38	3040413	TIRANTE PER PIEZO	PIEZO ROD
39	3040554	TIRANTE AD OCCHIO	ROD
40	2041970	GR. LAMIENE CON ALBERO	BLADES UNIT WITH SHAFT
41	2044370	GRUPPO DI LETTURA E SCATOLA	READING UNIT AND BOX
42	4592497	CONDENSATORE 220V	CAPACITOR 220V
43	4399122	RONDELLA DEN. ES. "A" 8.4x15x0.8	TOOTHED WASHER 8.4x15x0.8
44	4399976	DADO M8 6S ZNT 5588	NUT M8
45	2045080	GR. DATORE DI FASE + SCHEDA ELAB. A RICAMBIO	PICK UP BOARD + COMPUTER BOARD
46	2041944	GRUPPO LEVA PORTAFRENO COMPL.	BRAKE LEVER UNIT - COMPLETE
47	2044372	GR. CONDENSATORE 220 V.	CAPACITOR
48	2039926	GRUPPO TERMINALE FILETTATO D.40	THREADED END D.40
49	2044373	GRUPPO DI LETTURA E FRENO	READING UNIT AND BRAKE
50	4399827	VITE TE 8x20 8.8 ZNT 5739 (K)	SCREW 8x20

DA MATRICOLA : 22181900020
FROM SERIAL NUMBER: 22181900020

A = 115V VERSION

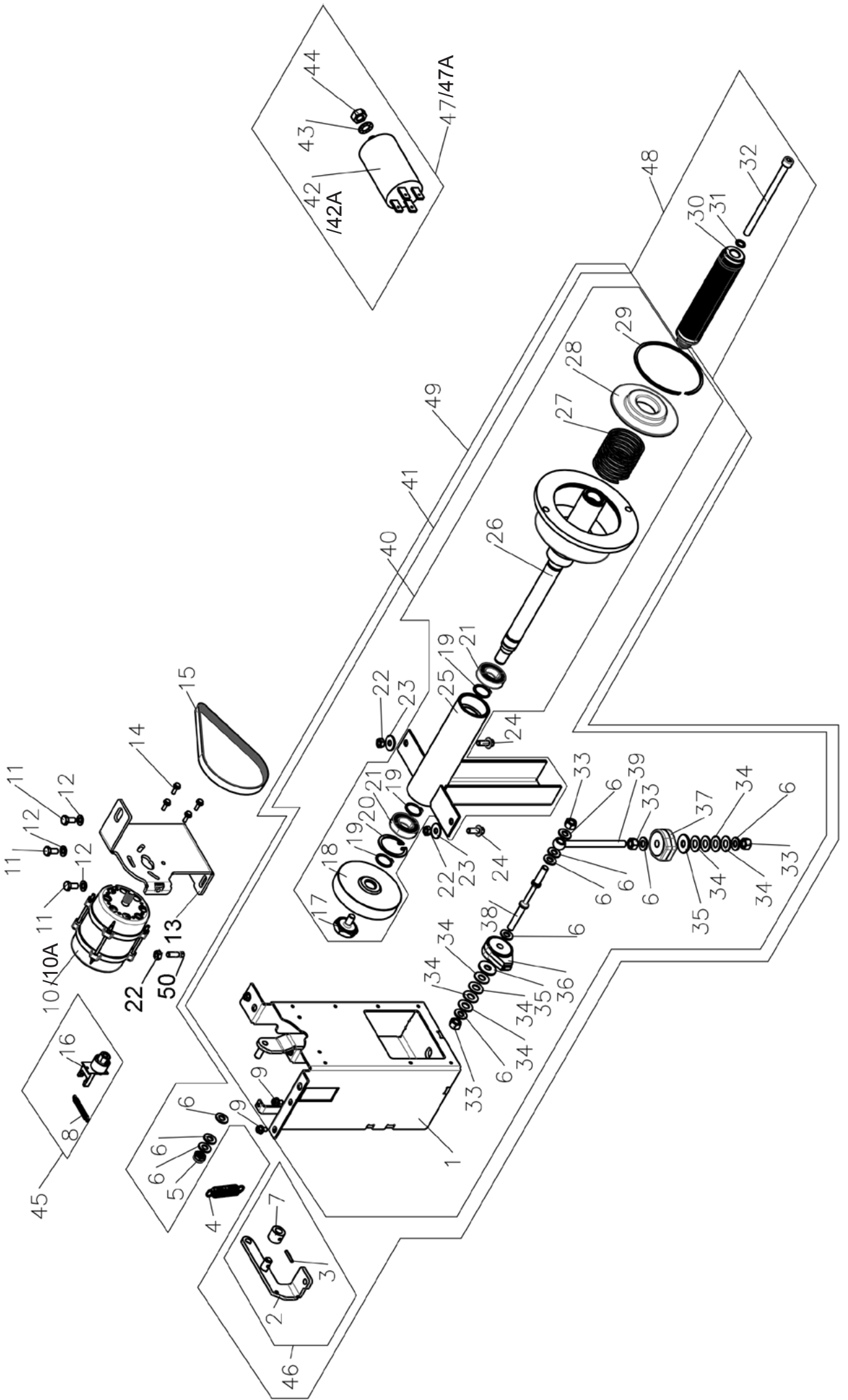

1	7041845	SCATOLA PIEZO FRENO	PIEZO BOX
2	2141945	LEVA PORTA FRENO COMPLETA	LEVER
3	4398783	SPINA ELASTICA D.4x24	ELASTIC PIN D.4x24
4	4292491	MOLLA 2x16x21 COD, B/1355	SPRING
5	4399971	DADO AUTOBL. M10 BASSO	SELF-LOCKING NUT M10
6	4399378	RONDELLA 10 (10.5x21x2)	WASHER 10 (10.5x21x2)
7	3040625	AMMORTIZZATORE LEVA PORTAFRENO	SHOCK ABSORBER
8	3041982	MOLLA DATORE DI FASE	PICK UP BOARD SPRING
9	4393123	VITE FLANG. AUTOF. TE 6.3x13	SCREW SELF-THREADING TE 6.3x13
10	4592434	MOTORE 0.12KW 1PH 230V 4 POLI	MOTOR
10A	4591943	MOTORE 0,12KW 1PH 115V 60hz materiali UL/CSA	MOTOR 0,12KW 1PH 115V 60hz materials UL/CSA
11	4399946	VITE TE 8x16	SCREW 8x16
12	4399829	RONDELLA 8 (8.4x16x1.5)	WASHER 8 (8.4x16x1.5)
13	3043330	PANTOGRAFATO ATTACCO MOTORE	MOTORE MOUNTING BRACKET
14	4392535	VITE FLANG. TENSOLock TE M5x10	SCREW 5x10
15	4292505	CINGHIA POLY-V TB2/7x480	BELT
16	2044276	GR.DATORE DI FASE S800 NEW "3,3V"	PHASE INDICATOR GROUP S.800
17	3040568	DADO BLOC. CONT. PULEGGIA	NUT FOR PULLEY
18	3038501	PULEGGIA	PULLEY
19	4399801	ANELLO SEEGER E D.25	SEEGER RING D.25
20	4399814	ANELLO SEEGER I D.47	SEEGER RING D.47
21	4296688	CUSCINETTO 6005-2Z 25/47/12	BEARING
22	4399976	RONDELLA 8 (9x24x2)	WASHER 8 (9x24x2)
23	4399863	DADO M8 6S	NUT M8
24	4393124	VITE FLANG. TE M8x20	SCREW 8x20
25	2143186	GRUPPO LAMINE COMPLETO	EDGES GROUP
26	7039924	GRUPPO ALBERO COMPLETO D40	COMPL. SHAFT
27	3040602	MOLLA COMP. GRUPPO DI LANCIO	SPRING
28	3038502	COPERCHIO PER MOLLA	SPRING COVER
29	4392506	ANELLO D'ARRESTO SB118	STOP RING
30	3039927	TERMINALE FILETTATO D.40	THREADED END
31	4393066	RONDELA SCHONORR MM10	KNURLED LOCK WASHER 10.5x16x1
32	4393070	VITE TCEI M10x160 8.8 P.F.	SCREW TCEI M10x160
33	4399969	DADO M10 6S ALTO	NUT M10
34	4398944	MOLLA A TAZZA 12.2x25x1.5	BELLEVILLE WASHER 12.2x25x1.5
35	4398944	RONDELLA 10 (11x30x2.5) 6593-C	WASHER 10 (11x30x2.5)
36	2041803	PIEZO DINAMICO	DINAMIC PIEZO
37	2041802	PIEZO STATICO	STATIC PIEZO
38	3040413	TIRANTE PER PIEZO	PIEZO ROD
39	3040554	TIRANTE AD OCCHIO	ROD
40	2041970	GR. LAMINE CON ALBERO	PLATES WITH SHAFT
41	2044370	GRUPPO DI LETTURA E SCATOLA	READING UNIT AND BOX
42	4592497	CONDENSATORE 220V	CAPACITOR 220V
42A	4591912	CONDENSATORE 45 uF S800	CAPACITOR 45 uF S800
43	4399122	RONDELLA DEN. ES. "A" 8.4x15x0.8	TOOTHED WASHER 8.4x15x0.8
44	4399976	DADO M8 6S ZNT 5588	NUT M8
45	2045005	GR. DATORE DI FASE E MOLLA 3,3V	PICK UP BOARD AND SPRING 3,3V
46	2041944	GRUPPO LEVA PORTAFRENO COMPL.	BRAKE LEVER UNIT
47	2044372	GR. CONDENSATORE 220 V.	CAPACITOR ASSEMBLY 220 V.
47A	2044588	GR. CONDENSATORE 115V	CAPACITOR ASSEMBLY 115V
48	2039926	GRUPPO TERMINALE FILETTATO D.40	THREADED END D.40
49	2044373	GRUPPO DI LETTURA E FRENO	READING UNIT AND BRAKE
50	4399827	VITE TE 8x20 8.8 ZNT 5739 (K)	SCREW 8x20

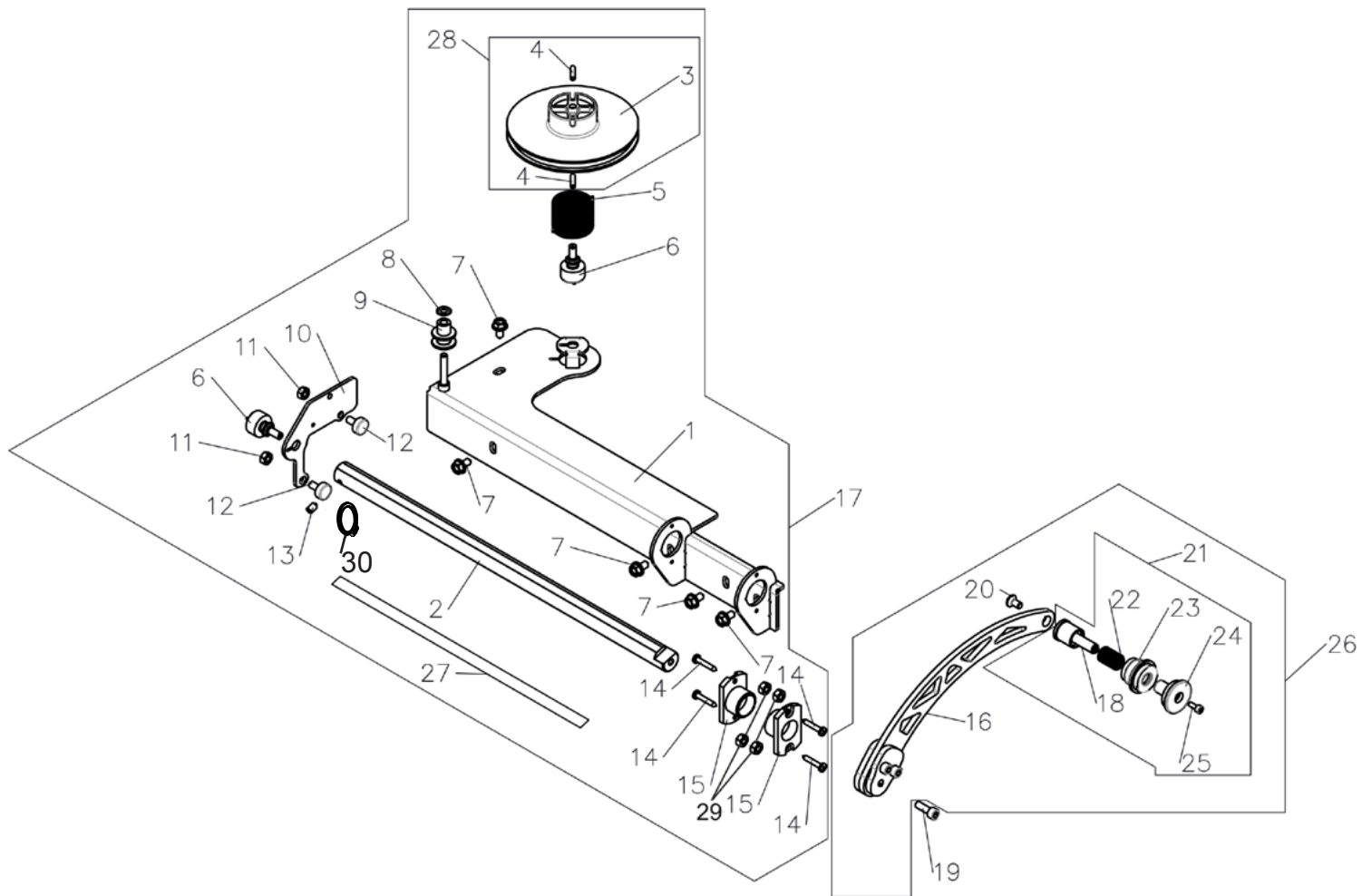

1	7041927	SUPPORTO CALIBRO SALDATO	CALIBER SUPPORT
2	3041957	ASTA CALIBRO	CALIBER ROD
3	3040074	PULEGGIA POTENZIOMETRO	POTENTIOMETER PULLEY
4	4393180	VITE STEI 4x20 P.P.	SCREW STEI 4x20 P.P.
5	3040662	MOLLA A TORISIONE	SPRING
6	2040732	POTENZIOMETRO DIAM.-DIST.	POTENTIOMETER WITH CABLE
7	4393123	VITE FLANG. AUTOF. TE 6.3x13	SCREW 6.3x13
8	4392490	ANELLO QUICKLOCK D.6	QUICKLOCK RING D.6
9	3040592	PULEGGIA DI RINVIO	PULLEY
10	3041956	PANT. ANTOROTAZIONE CALIBRO	GAUGE ANTI-ROTATION PLATE
11	4399889	DADO M6 6S ZNT 5588	NUT M6
12	4292511	PIED. ZIGRINATO CON PERNO FILET.	PLASTIC SPACER
13	4398532	VITE STEI 6x6 P.CONICA 5927 (K)	SCREW 6x6 5927
14	4399905	VITE TE 4x12 8.8 ZNT 5739 (K)	SCREW 4x12
15	3041933	BOCCOLA GUIDA CALIBRO	BUSH
16	2041209	GRUPPO INDICE CALIBRO	DISTANCE GAUGE ASSEMBLY
17	2044374	GRUPPO ASTA CALIBRO E POTENZIOMETRI	ROD FOR DISTANCE GAUGE AND POTENTIOMETERS
18	3041952	PERNO INDICE GUIDA PINZA	PIN
19	4399584	VITE TCEI M6x18 8.8	SCREW 6x18
20	4397324	VITE TSPEI M6x12 10.9 ZNT 5933	SCREW 6x12
21	2041951	GR. PINZA CALIBRO COMPLETA	CALIPER CLAMP
22	4292531	MOLLA DE 13 DI 14.6 F0.8	SPRING DE13 DI14.6 F0.8
23	3041953	PINZA SCORREVOLE	SLIDING CALIPER
24	3041954	RISCONTRO GIREVOLE	REVOLVING RESET
25	4394022	VITE TCEI M 4x10 8.8 ZNT 5931	SCREW TCEI M 4x10 8.8 ZNT 5931
26	2044375	INDICE CALIBRO COMPLETO DI PINZA	DISTANCE GAUGE AND PLIER
27	3040653	DACALCO ASTA CALIBRO	CALIPER DECAL
28	2044376	GRUPPO PULEGGIA E VITI	PULLEY ASSEMBLY, AND SCREWS
29	4399895	DADO AUTOBL.M 4 BASSO.6S. 7474 (K)	SELF-LOCKING NUT M4
30	4399975	ANELLO SEEGER E D.20 7435 (K)	SEEGER RING D.20

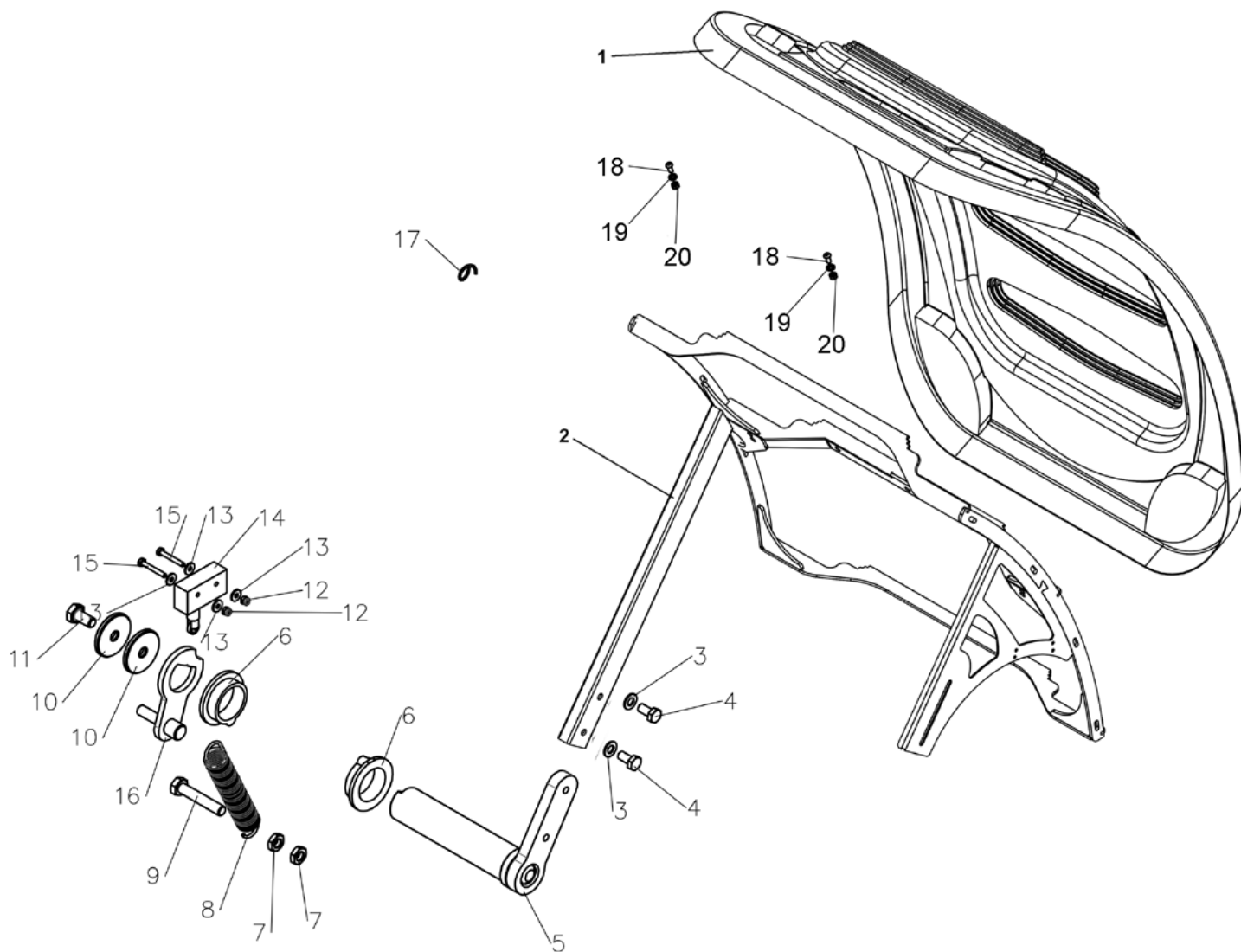

Rif. Ref.	Codice Code	Descrizione Articolo	Description
1	3034979	GUSCIO ABS PROTEZIONE RUOTA	ABS WHEEL GUARD
2	6636248	TELAIO PER ABS PROTEZIONE RUOTA VERN - NERO	FRAME FOR ABS WHEEL GUARD - PAINTED BLACK
3	4399863	RONDELLA 8 (9x24x2) ZNT 6593 (K)	WASHER 8 (9x24x2)
4	4399946	VITE TE 8x16 8.8 ZNT 5739 (K)	SCREW 8x16
5	2139964	SUPPORTO PROTEZIONE - ZINC. B.	WHEEL GUARD SUPPORT
6	3040637	BOCCOLA PER TELAIO	FRAME BUSHING
7	4399967	DADO M10 6S BASSO ZNT 5589 (K)	NUT M10
8	3000114	MOLLA BRACCIO STALLONATORE	SPRING
9	4399933	VITE TE 10x50 8.8 PF ZNT 5737 (S) (K)	SCREW 10x50
10	4395669	RONDELLA 10 (11x40x2,5)ZNT6592	WASHER 10 (11x40x2,5)
11	4399966	VITE TE 10x20 8.8 ZNT 5739 (S) (K)	SCREW 10x20
12	4399895	DADO AUTOBL.M 4 BASSO.6S. 7474 (K)	SELF-LOCKING NUT M4
13	4399903	RONDELLA 4 (4,5x12x1,5)ZNT6593 (*) (K)	WASHER 4 (4,5x12x1,5)
14	2040725	MICRO PROTEZIONE RUOTA COMPLETO DI CAVO	WHEEL GUARD MICROSWITCH WITH CABLE
15	4399898	VITE TE 4x30 8.8 PF ZNT 5737 (K)	SCREW 4x30
16	2142008	PERNO CAMMA PROTEZIONE RUOTA - ZINC. B.	WHEEL GUARD CAM PIN
17	4299720	FASCETTA STRAP.188X4,5-41802/N	CLAMP 188x4,5
18	4392120	VITE TBEI M 6x14 BRUNITA 10.9	SCREW
19	4392121	RONDELLA 6 (6,4x12x1,6) BRUNITA 6592	WASHER 6 (6,4x12x1,6)
20	4392122	DADO M 6 BRUNITO 5588	NUT M6

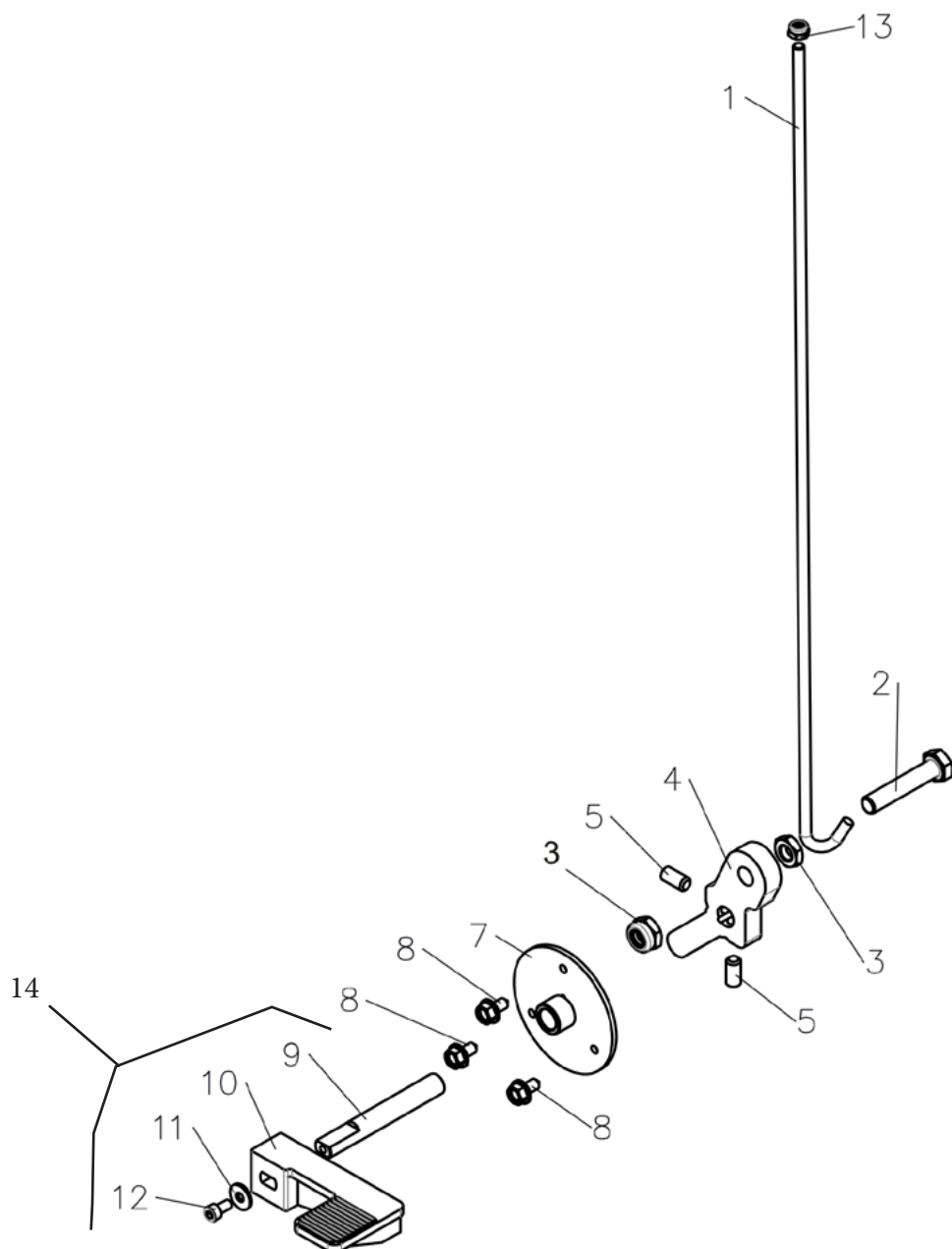

1	3042005	ASTA FRENO A PEDALE	PEDAL BRAKE SHAFT
2	4399933	VITE TE 10x50 8.8 PF ZNT 5737	SCREW 10x50
3	4399967	DADO M10 6S BASSO	NUT M10
4	3041965	LEVA PEDALE FRENO	PEDAL BRAKE LEVER
5	4398214	VITE STEI 8x16 P.P.	SCREW 8x16
7	2141962	LAMIERA SALD. FIS. PEDALE FRENO	PEDAL BRAKE FIXING PLATE
8	4393123	VITE FLANG. AUTOF. TE 6.3x13	SELF-TAPPING SCREW TE 6.3x13
9	3037097	PERNO PER PEDALE IN PLASTICA	PLASTIC PEDAL PIN
10	3041967	PEDALE FRENO	PEDAL BRAKE
11	4399430	RONDELLA 5 (5.5x15x1.6)	WASHER 5 (5.5x15x1.6)
12	4398548	VITE TCEI M5x10 8.8	SCREW 5x10
13	4399893	DADO AUTOBL. M6 BASSO	SELF-LOCKING NUT M6
14	2041966	GR. PEDALE FRENO	BRAKE PEDAL

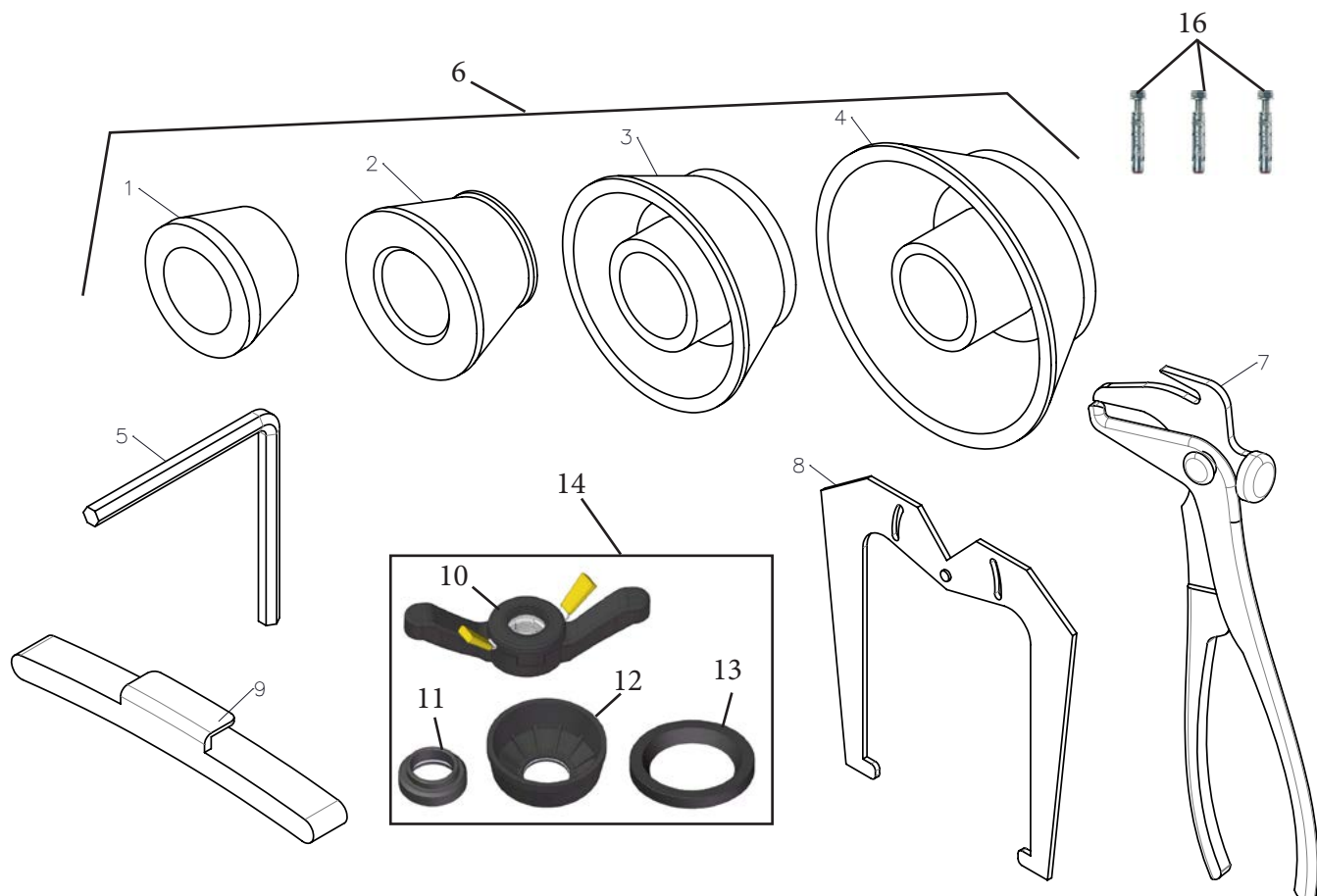

Rif. Ref.	Codice Code	Descrizione Articolo	Description
1	3043947	CONO "A" 45/62	CONE "A" 45/62
2	3043948	CONO "B" 53/78	CONE "B" 53/78
3	3043949	CONO "C" 74/107	CONE "C" 74/107
4	3043950	CONO "D" 89/140	CONE "D" 89/140
5	3044149	CHIAVE ES. 8MM	HEXAGONAL WRENCH 8MM
6	2042387	SET 4 CONI DI 40 MM	SET OF 4 CONES 40 MM
7	4292190	PINZA X CONTRAPPESI RUOTA	PLIER
8	2042388	CALIBRO RUOTA (LARGH.-DIAMETRO)	GAUGE
9	4295063	PESO 60 GR. in ZINCO PLAST. x EQUILIBR.	60 GR WEIGHT FOR W.BALANCERS
10	2044377	GHIERA	RING NUT
11	3044378	DISTANZIALE PIATTO	SPACER
12	3044379	DISTANZIALE A CALOTTA	CAR SPACER
13	3044380	PROTEZIONE IN GOMMA PER CALOTTA	CAP RUBBER PROTECTION
14	2042386	GR. GHIERA E DISTANZIALI	RING NUT AND SPACERS
15	2040681	GR.DOTAZIONE	STANDARD SUPPLY
16	4393027	TASSELLO ANCORANTE M.8X50	SCREW ANCHOR



GIULIANO INDUSTRIAL S.p.a. - Via Guerrieri, 6 - 42015 Correggio (RE) ITALY