

**SBM 135 A**



de Ersatzteilliste

fr Liste de recambio

en Spare part list

es Lista de piezas de recambio

Class	----- de -----	----- en -----	----- fr -----	----- es -----	----- it -----
●	<b>Verschleißteil:</b> <b>Definition:</b> Zu erwartende Lebensdauer des Teiles ist kleiner als die zu erwartende Lebensdauer des Produktes!  - Bei Ausfall nicht mehr funktionsfähig oder sicherer Einsatz des Produktes nicht mehr gewährleistet - Verminderte Gewährleistung - Wir empfehlen, diese Ersatzteile im lokalem Lager zu bevorraten.  Hinweis: Der Verschleiß und das Wartungsintervall sind abhängig von: - der Einsatzzeit - Art und Häufigkeit der Verwendung - Alter der Maschine	<b>Wearing part:</b> <b>Definition:</b> The expected lifetime of the part is shorter than the expected lifetime of the product!  - In the event of failure, no longer functional or safe use of product no longer guaranteed - Reduced warranty - We recommend stocking these replacement parts in the local warehouse.  Note: Wear and the maintenance interval depend on: - Usage time - Nature and frequency of use - Age of machine	<b>Pièce d'usure :</b> <b>Définition :</b> La durée de vie prévisible de la pièce est inférieure à la durée de vie prévisible du produit !  - Plus en ordre de marche en cas de panne ou utilisation sûre du produit plus garantie - Garantie réduite - Nous conseillons d'avoir ces pièces de rechange en réserve dans un entrepôt local.  Remarque : L'usure et l'intervalle d'entretien dépendent des facteurs suivants : - durée d'utilisation - nature et fréquence de l'utilisation - âge de la machine	<b>Pieza de desgaste:</b> <b>Definición:</b> La vida útil esperada de la pieza es menor que la vida útil esperada del producto.  - En caso de avería ya no está en condiciones de funcionar o el uso seguro del producto ya no se garantiza - Garantía reducida - Se recomienda almacenar esas piezas de recambio en un almacén local.  Nota: El desgaste y el intervalo de mantenimiento dependen: - del tiempo de servicio - del tipo y frecuencia de uso - de la edad de la máquina	<b>Parte soggetta a usura:</b> <b>Definizione:</b> Il ciclo di vita prevedibile del componente è inferiore al ciclo di vita prevedibile del prodotto.  - In caso di avaria il prodotto non è più in grado di funzionare oppure non ne è più garantita la sicurezza d'impiego - Garanzia ridotta - Consigliamo di tenere una scorta di questi ricambi nel magazzino ocale.  Avvertenza: l'usura e l'intervallo di manutenzione dipendono da: - tempo operativo - tipo e frequenza dell'impiego - età della macchina
⊖	<b>Funktionsteil:</b> <b>Definition:</b> Die zu erwartende Lebensdauer des Teiles ist gleich oder größer als die zu erwartende Lebensdauer des Produktes!  - Bei Ausfall nicht mehr funktionsfähig oder sicherer Einsatz des Produktes nicht mehr gewährleistet - Standard Gewährleistung - Wir empfehlen, diese Ersatzteile im lokalem Lager zu bevorraten.	<b>Function part:</b> <b>Definition:</b> The expected lifetime of the part is the same as or longer than the expected lifetime of the product!  - In the event of failure, no longer functional or safe use of product no longer guaranteed - Standard warranty - We recommend stocking these replacement parts in the local warehouse.	<b>Pièce fonctionnelle :</b> <b>Définition :</b> La durée de vie prévisible de la pièce est égale ou supérieure à la durée de vie prévisible du produit !  - Plus en ordre de marche en cas de panne ou utilisation sûre du produit plus garantie - Garantie standard - Nous conseillons d'avoir ces pièces de rechange en réserve dans un entrepôt local.	<b>Pieza funcional:</b> <b>Definición:</b> La vida útil esperada de la pieza es igual o mayor que la vida útil esperada del producto.  - En caso de avería ya no está en ndiciones de funcionar o el uso seguro del producto ya no se garantiza - Garantía estándar - Se recomienda almacenar esas piezas de recambio en un almacén local.	<b>Parte funzionale:</b> <b>Definizione:</b> Il ciclo di vita prevedibile del componente è uguale o superiore al ciclo di vita prevedibile del prodotto.  - In caso di avaria il prodotto non è più in grado di funzionare oppure non ne è più garantita la sicurezza d'impiego - Garanzia standard - Consigliamo di tenere una scorta di questi ricambi nel magazzino locale.
○	<b>Nicht-Funktionsteil:</b> <b>Definition:</b> Die zu erwartende Lebensdauer des Teiles ist gleich oder größer als die zu erwartende Lebensdauer des Produktes!  - Bei Ausfall weiterhin funktionsfähig und ein sicherer Einsatz des Produktes ist gewährleistet - Standard Gewährleistung - Wir empfehlen, diese Ersatzteile bei einem Bedarf über das Zentrallager zu bestellen.	<b>Non-function part:</b> <b>Definition:</b> The expected lifetime of the part is the same as or longer than the expected lifetime of the product!  - In the event of failure, still functional and safe use of the product is guaranteed - Standard warranty - We recommend ordering these replacement parts as required via the central warehouse.	<b>Pièce non fonctionnelle :</b> <b>Définition :</b> La durée de vie prévisible de la pièce est égale ou supérieure à la durée de vie prévisible du produit !  - Toujours en ordre de marche en cas de panne et utilisation sûre du produit garantie - Garantie standard - Nous recommandons de commander ces pièces de rechange au besoin par le biais de l'entrepôt central.	<b>Pieza no funcional:</b> <b>Definición:</b> La vida útil esperada de la pieza es igual o mayor que la vida útil esperada del producto.  - En caso de avería aún en condiciones de funcionar y el uso seguro del producto se garantiza - Garantía estándar - Se recomienda pedir esas piezas de recambio al almacén central, en caso de necesidad.	<b>Parte non funzionale:</b> <b>Definizione:</b> Il ciclo di vita prevedibile del componente è uguale o superiore al ciclo di vita prevedibile del prodotto.  - In caso di avaria il prodotto continua ad essere in grado di funzionare e ne rimane garantita la sicurezza d'impiego - Garanzia standard - Consigliamo di ordinare questi ricambi in caso di necessità attraverso il magazzino centrale.
<b>Intervall</b>	<b>Wartungsintervall des Verschleißteiles</b>	<b>Maintenance intervall for wearing part</b>	<b>Intervalle d'entretien de la pièce d'usure</b>	<b>Intervalo de mantenimiento de la pieza de desgaste</b>	<b>Intervallo di manutenzione della parte soggetta a usura</b>
h	Stunden	hours	heures	Horas	ore
d	Tage	days	jours	Días	giorni
m	Monate	month	mois	Meses	mesi
cy	Zyklen	cycles	cycles	Ciclos	cicli
-	ohne definiertes Wartungsintervall	No defined maintenance interval	pas d'intervalle d'entretien défini	Sin intervalo de mantenimiento definido	senza intervallo di manutenzione definito
<b>Customer</b>	<b>Austausch des Teiles durch den Kunden (Werkstatt)</b>	<b>Replacement of part by customer (workshop)</b>	<b>Remplacement de la pièce par le client (atelier)</b>	<b>Sustitución de la pieza por el cliente (taller)</b>	<b>La sostituzione del componente da parte del cliente (officina)</b>
-	ist nicht erlaubt.	Not permissible.	pas autorisé	no está permitida.	non è ammessa.
x	ist erlaubt (Diese Ersatzteile sind auch in der Betriebsanleitung aufgeführt)	Permissible (these replacement parts are also listed in the operating instructions)	autorisé (ces pièces de rechange sont également indiquées dans la notice)	está permitida (estas piezas de recambio también se indican en las instrucciones de	è ammessa (questi ricambi sono riportati anche nelle istruzioni d'uso)
<b>Part-number</b>	<b>Bestellnummer des Ersatzteiles oder Verweis auf ein Standardteil</b>	<b>Order number of replacement part or reference to standard part</b>	<b>Référence de commande de la pièce de rechange ou signalement de pièce normalisée</b>	<b>Número de pedido de la pieza de recambio o nota sobre la pieza normalizada</b>	<b>Codice di ordinazione del ricambio o avvertenza sul componente unificato</b>
<b>Normpart</b>	<b>Normteil:</b> Ersatzteile, die normalerweise über unterschiedliche Kanäle bezogen werden können wie z. B. Schrauben, Muttern, O-Ringe, Tintenpatronen. Alle 3 Ersatzteil-Kategorien (siehe Class) sind möglich	<b>Normpart (Standard part):</b> Replacement parts which can normally be obtained through various channels e.g. bolts, nuts, O-rings, ink cartridges. All 3 replacement part categories (refer to Class) are possible	<b>Pièce normalisée :</b> Pièces de rechange qui peuvent normalement être obtenues par le biais de différents canaux, par ex. les vis, écrous, joints toriques, cartouches d'encre. Les 3 catégories de pièces de rechange (voir Class) sont possibles	<b>Pieza normalizada:</b> Piezas de recambio que se pueden adquirir normalmente a través de diferentes vías, p. ej., tornillos, tuercas, anillos de sección circular, cartuchos de tinta. Las tres categorías de piezas de recambio (véase clase) son posibles.	<b>Parte unificata (componente unificato):</b> Si tratta di ricambi che in genere possono essere acquistati attraverso diversi canali, come ad es. viti, dadi, O-ring, cartucce di inchiostro. Sono possibili tutte e 3 le categorie di ricambi (vedi Class)

## SBM 135 A

Bezeichnung Designation Dénomination Designación	Bestellnummer Partnumber Référence Núm.depedido	Gefertigt von Production since fabrication de fabricación de	Gefertigt bis produced until fabrication fabricación	Ersatzteilkpflicht bis Service part obligation Obligation de pièce de rechange Obligación de disp. de piezas de recambio	Bemerkungen Notes Notes Notas
SBM 135 A	1694300091	Aug 12			1 x 230V, 50/60Hz, RAL colour red 3000
SBM 135 A	1694300092	Aug 12			1 x 110V, 50/60Hz, RAL colour red 3000
SBM 135 A	1694300093	Aug 12			1 x 230V, 50/60Hz, RAL colour blue 5015
SBM 135 A	1694300094	Aug 12			1 x 110V, 50/60Hz, RAL colour blue 5015

Pos.	Class	Intervall	Customer	Partnumber	IDENTIFICATION (it)	IDENTIFICATION (fr)	Drawing
					IDENTIFICATION (en)	IDENTIFICACION (es)	
					Comment (it)	Comment (en)	
1	●	-	-	1695655613	Circuito Stampato	Circuit Imprime	
					Printed Circuit Board	Tarjeta Circ Impreso	
2	●	-	-	1695655626	Lamiera Di Acciaio	Tole D'acier	
					Jeu De Pieces	Chapa De Acero	
3	○	-	X	Normpart	Vite Autofilettante	Vis Autotaraudeuse	
					Thread-Forming Screw	Tornillo Autorroscante	
					ISO 7049 3,9x13		
4	●	-	-	1695041409	Interruttore	Commutateur	
					Switch	Interruptor	
5	●	-	-	1695042225	Presa Per Apparecchio	Prise Femelle D'appareil	
					Equipment Socket	Enchufe Hembra Aparato	
6	●	-	-	1695600051	Pezzo Stampato Plastica	Couverture de plastique	
					plastic covering	cubierta de plástico	
					Ral 9005		
7	○	-	-	Normpart	Vite bombata esagonale	Vis tête cyl bombée plate	
					Hex Socket Button Screw	Tornillo abombada hex	
					ISO 7380 M6x16		
801	○	-	-	1695655674	Circuito Stampato	Circuit Imprime	
					Printed Circuit Board	Tarjeta Circ Impreso	

Pos.	Class	Intervall	Customer	Partnumber	IDENTIFICATION (it)	IDENTIFICATION (fr)	Drawing
					IDENTIFICATION (en)	IDENTIFICACION (es)	
					Comment (it)	Comment (en)	
1	O	-	X	1695627500	Supporto	Fixation	
					Holder	Sujecion	
2	O	-	X	Normpart	Vite Autofilettante	Vis Autotaraudeuse	
					Jeu De Pieces	Tornillo Autorroscante	
					ISO 7053 6,3x16		
3	O	-	X	Normpart	Vite bombata esagonale	Vis tête cyl bombée plate	
					Hex Socket Button Screw	Tornillo abombada hex	
4	●	-	-	in work	Unita Comando E Display	Unite Comande/Affichage	
					Control/Display Unit	Cuadro De Maniobras/Indi	
5	●	-	-	1695600009	Pezzo Stampato Plastica	Couverture de plastique	
					plastic covering	cubierta de plástico	
6	O	-	X	Normpart	Vite bombata esagonale	Vis tête cyl bombée plate	
					Hex Socket Button Screw	Tornillo abombada hex	
7	●	-	-	1695655526	Pezzo Stampato Plastica	Piece Injectee Plastique	
					Injection Moulded Part	Pieza Moldead Inyeccion	
8	●	-	-	1695653597	Copertura	Recouvrement	
					Cover	Cubierta	
9	●	-	-	1695600000	Pannello Frontale	Plaque Avant	
					Front Plate	placa frontal	

Pos.	Class	Intervall	Customer	Partnumber	IDENTIFICATION (it)	IDENTIFICATION (fr)	Drawing
					IDENTIFICATION (en)	IDENTIFICACION (es)	
					Comment (it)	Comment (en)	
1	●	-	X	1695041456	Fascetta Stringitubo	Collier Pour Tuyau Souple	
					Hose Clamp	Abrazadera P. Tubo Flex.	
					ISO 10642 M8x50		
2	●	-	-	1695653049	Disco In Plastica	Rondelle De Plastique	
					Plastic Disc	Disco Plastico	
3	●	-	-	1695653050	Disco	Rondelle	
					Washer	Arandela	
4	●	-	-	1695653272	Barra Fotoelettrica	Barriere Photoelectrique	
					Photoelec. Light Barrier	Barrera De Luz	
5	●	-	-	Normpart	Vite cilindrica esagonal	Vis cyl SixPans Creux CHC	
					Hex Socket Head Cap Screw	Tornillo cilíndrica hex	
					ISO 4762 M6x10		
6	●	-	-	Normpart	Disco	Rondelle	
					Washer	Arandela	
					ISO 7089 6		
7	●	-	-	Normpart	Vite cilindrica esagonal	Vis cyl SixPans Creux CHC	
					Hex Socket Head Cap Screw	Tornillo cilíndrica hex	
					ISO 4762 M10x16		
8	●	-	-	1695655285	Puleggia	Poulie	
					Pulley	Polea	
9	●	-	-	Normpart	Vite cilindrica esagonal	Vis cyl SixPans Creux CHC	
					Hex Socket Head Cap Screw	Tornillo cilíndrica hex	
					ISO 4762 M10x25		
10	●	-	-	Normpart	Disco	Rondelle	
					Washer	Arandela	
					ISO 7089 10		

Pos.	Class	Intervall	Customer	Partnumber	IDENTIFICATION (it)	IDENTIFICATION (fr)	Drawing							
					IDENTIFICATION (en)	IDENTIFICACION (es)								
					Comment (it)	Comment (en)								
11	O	-	-	Normpart	Rondella piana	Rondelle plate								
					Plain Washer	Arandela plana								
					ISO 7093-2 10,5x40x3									
12	●	-	-	1695654776	Rilevatore Di Percorrenza	Capteur De Deplacement								
					Displacement sensor	Registrador De Reorrido								
13	●	-	-	1695654777	Rilevatore Di Percorrenza	Capteur De Deplacement								
					Displacement sensor	Registrador De Reorrido								
14	●	-	-	1695653291	Vite testa esagonale	Vis Tête Hexagonale								
					Hex Screw	Tornillo Cabeza Hex								
15	●	-	-	1695040430	sfera d'acciaio	bille en acier								
					steel ball	bola de acero								
16	●	-	-	Normpart	Dado Esagonale	Ecrou Hex								
					Hex Nut	Tuerca Hex								
					ISO 8675 MA10									
17	●	-	-	1695040428	sfera d'acciaio	bille en acier								
					steel ball	bola de acero								
18	●	-	-	Normpart	Vite Cilindrka	Vis Sans Tete								
					Headless Screw	Piton Roscado								
					ISO 4029 M10x25									
19	●	-	-	Normpart	Vite cilindrica esagonal	Vis cyl SixPans Creux CHC								
					Hex Socket Head Cap Screw	Tornillo cilindrca hex								
					ISO 4762 M10x25									
20	O	-	-	Normpart	Disco	Rondelle								
					Washer	Arandela								
					ISO 7089 10									

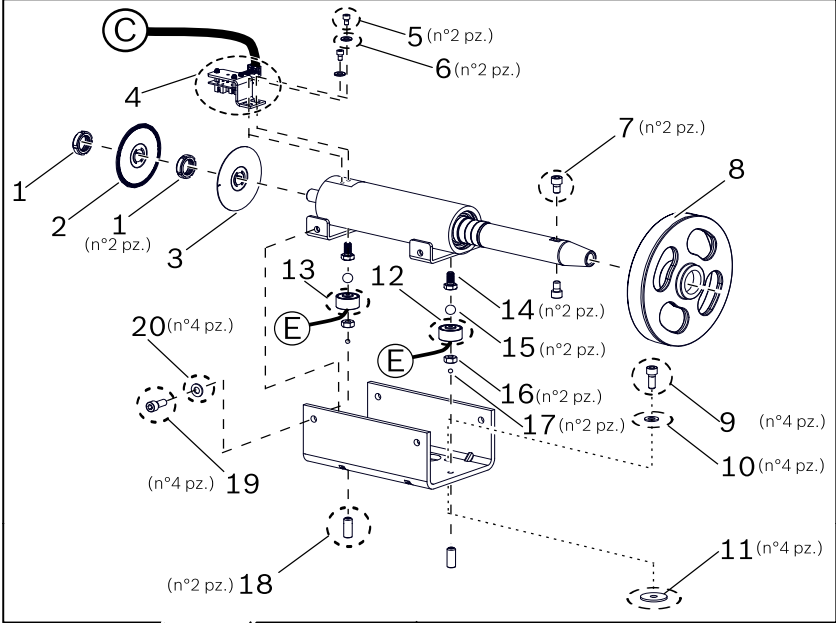
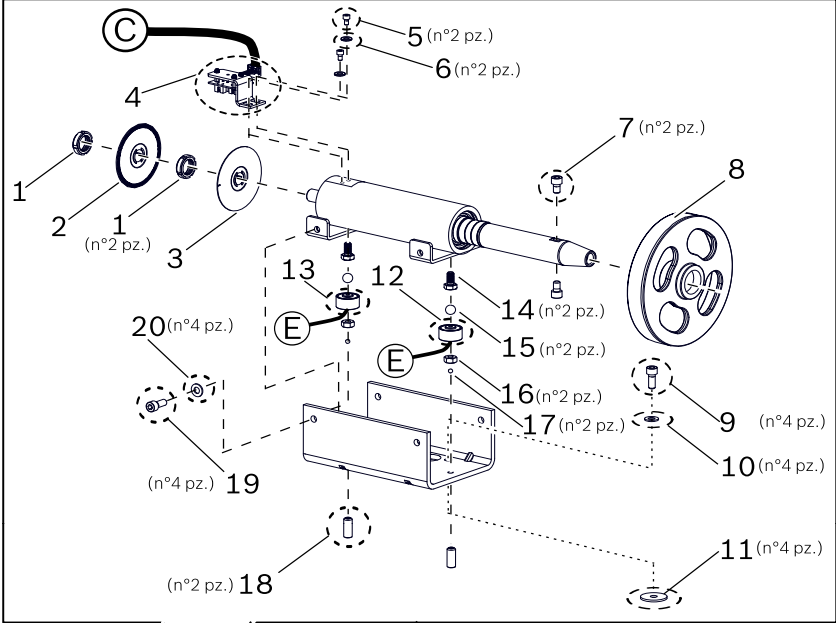
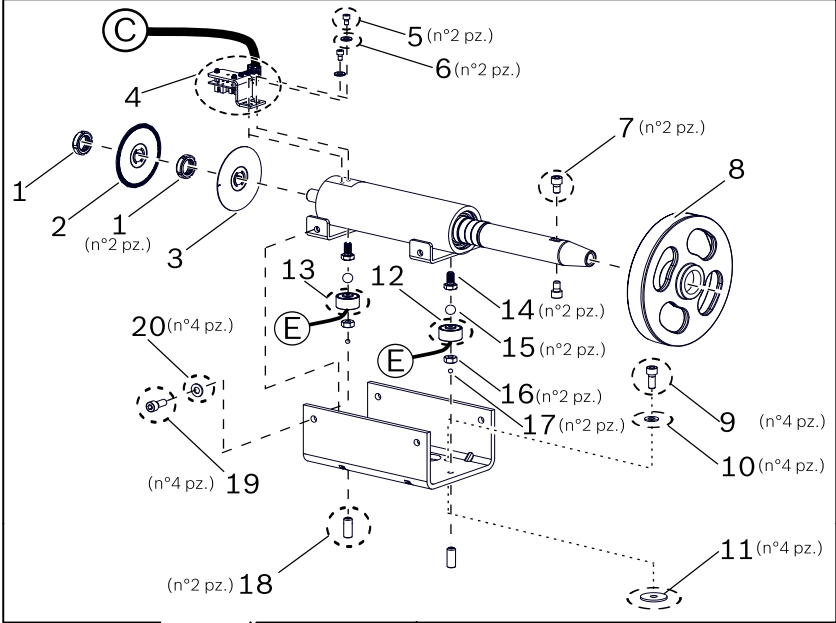
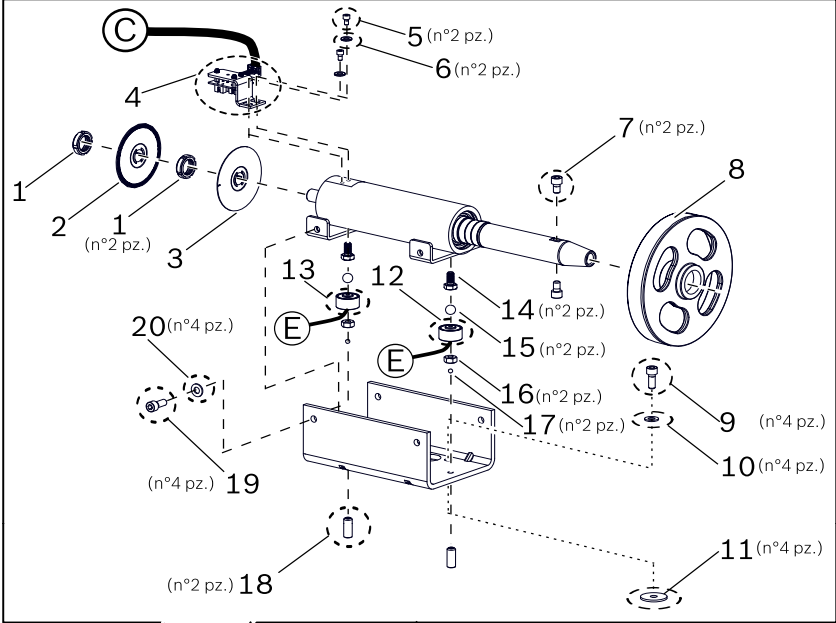
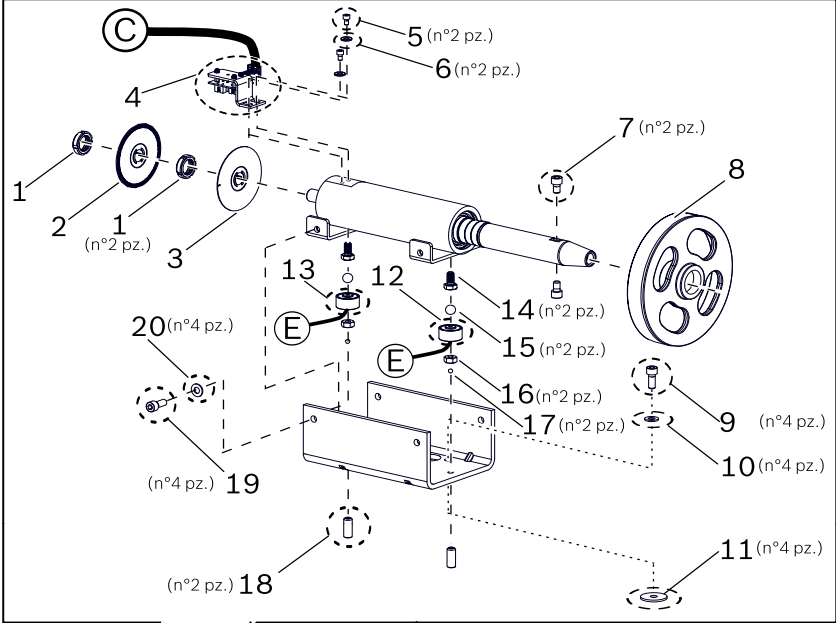
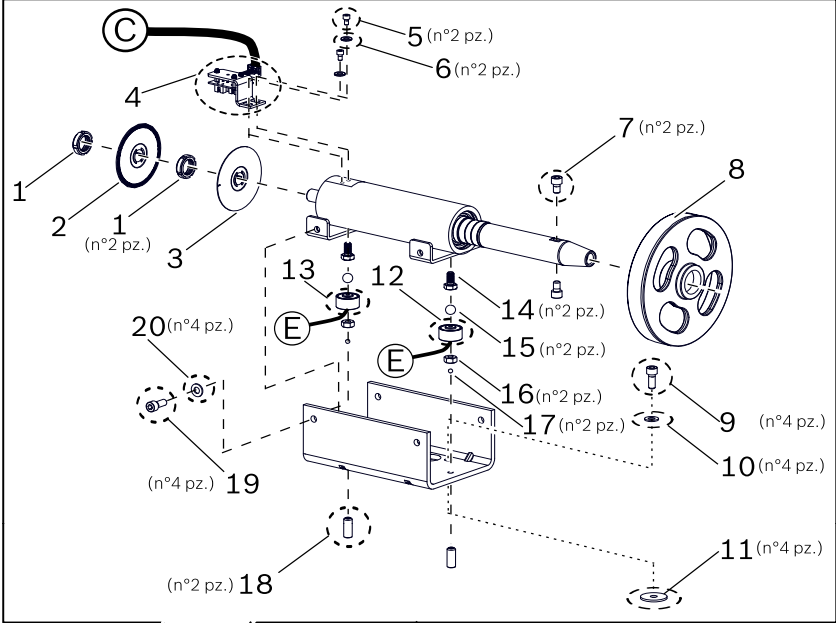
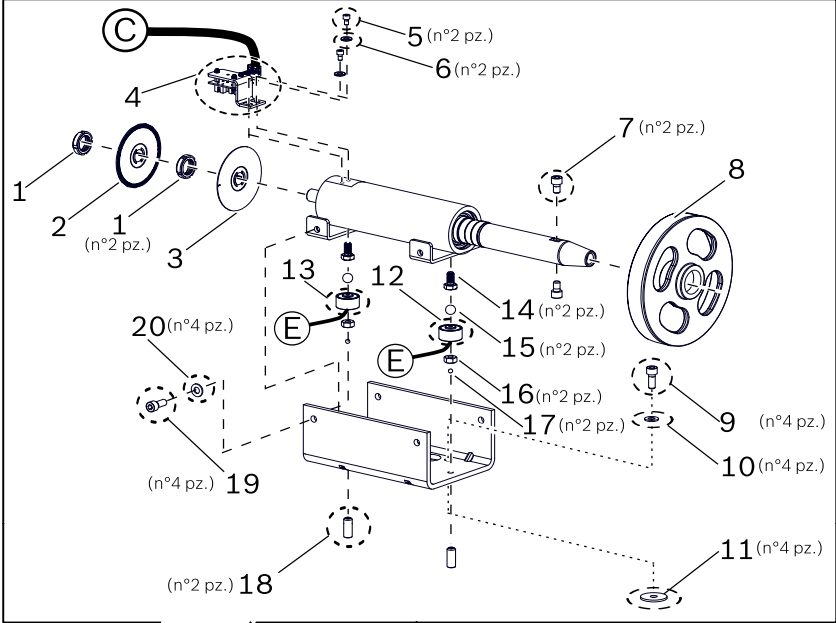
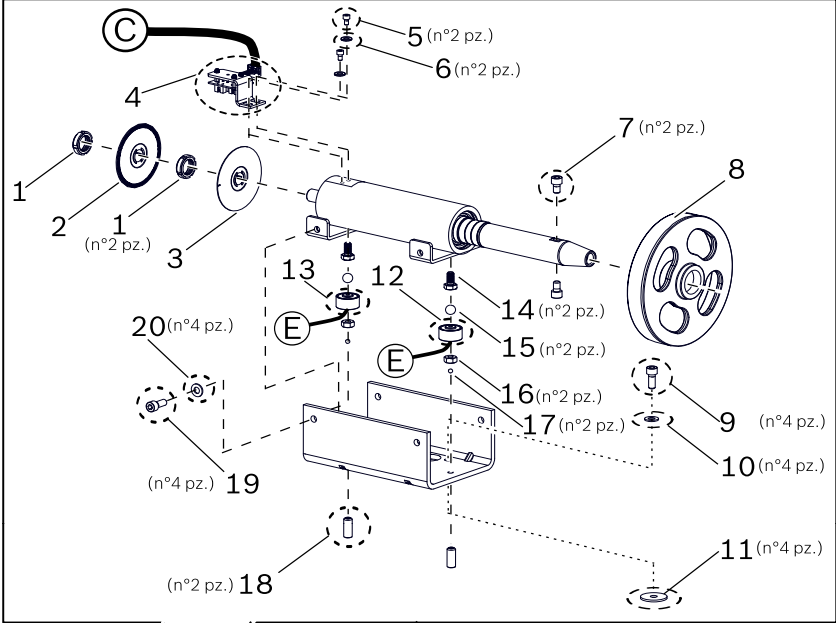
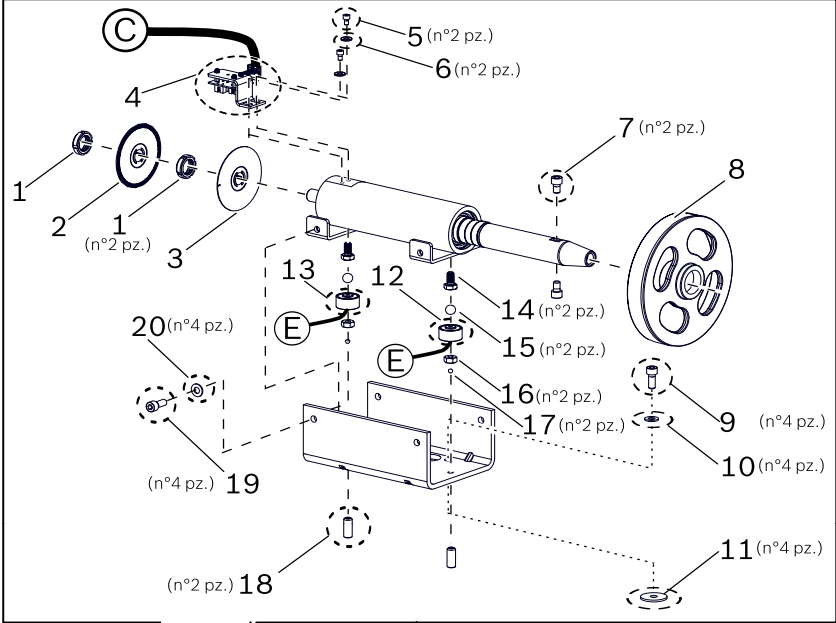
Pos.	Class	Intervall	Customer	Partnumber	IDENTIFICATION (it)	IDENTIFICATION (fr)	Drawing
					IDENTIFICATION (en)	IDENTIFICACION (es)	
					Comment (it)	Comment (en)	
21	●	-	X	1695605600	Cono	Cone	
					Cone	Cono	
					D. 75-110 mm		
22	●	-	X	1695652862	Cono	Cone	
					Cone	Cono	
					D. 54-80 mm		
23	●	-	X	1695632500	Cono	Cone	
					centering cone	Cono	
					D. 42-65 mm		
24	●	-	X	1695624800	Anello Di Gomma	Bague En Caoutchouc	
					Rubber Ring	Anillo De Goma	
25	●	-	X	1695616500	Manicotto	Joint En U	
					Sleeve	Manguito	
26	⦿	-	-	1695616200	Dispos Staffatura Rapida	Disp. Fixation Rapide	
					Quick-Clamping Device	Disp. Fijacion Rapida	
27	○	-	-	1695635000	Chiave cilindrica esagonal	Cle Male Coudee Pour Vis	
					Hexagon Socket Screw Key	Llave Con Macho Hexagona	
					CH 14		
801	⦿	-	-	1695655660	Sistema misuraz.	Système de mesure	
					Measuring system	Sistema medidor	
802	⦿	-	-	1695602400	Dado Di Serraggio Rapido	Ecrou De Blocage Rapide	
					Fast Locking Flange	Tuerca De Cierre Rapido	

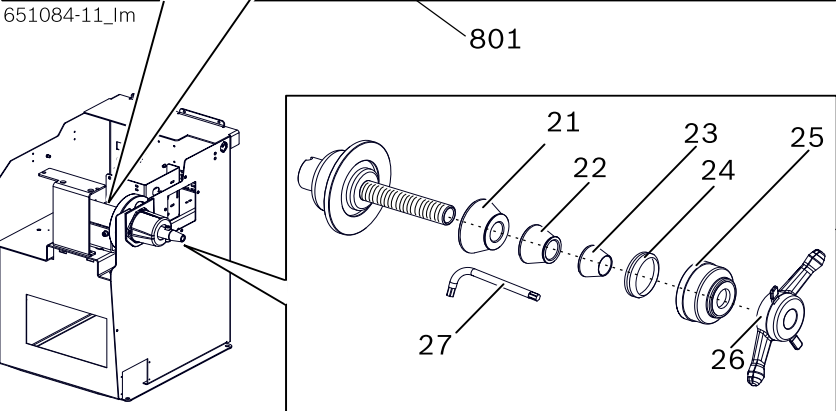
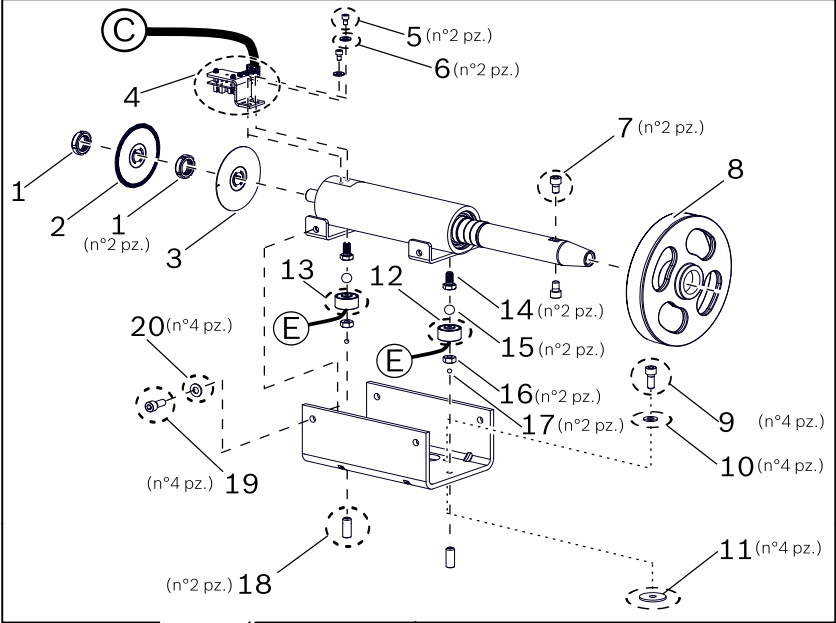



Pos.	Class	Intervall	Customer	Partnumber	IDENTIFICATION (it)	IDENTIFICATION (fr)	Drawing
					IDENTIFICATION (en)	IDENTIFICACION (es)	
					Comment (it)	Comment (en)	
1	O	-	-	Normpart	Vite svasata esagonale	Vis tête fraisée six pans	
					Hex socket countrsk screw	Tornillo Avellanada Hex	
					ISO 10642 M8x50		
2	●	-	-	1695655619	Perno Snodato	Axe De Chape	
					Pivot Pin	Perno De Articulacion	
3	●	-	-	1695634500	Molla	Ressort	
					Spring	Resorte	
4	●	-	-	1695632900	Ganascia Del Freno	Segment De Frein	
					Brake Shoe	Zapata De Freno	
5	O	-	-	Normpart	Vite cilindrica esagonal	Vis cyl SixPans Creux CHC	
					Hex Socket Head Cap Screw	Tornillo cilndrica hex	
					ISO 4762 M5x14		
6	O	-	-	Normpart	Dado	Ecrou	
					Nut	Tuerca	
7	O	-	-	Normpart	Dado	Ecrou	
					Nut	Tuerca	
8	O	-	-	Normpart	Accessorio	Accessoire	
					Accessory Part	Accesorio	
9	O	-	-	Normpart	Vite Autofilettante	Vis Autotaraudeuse	
					Thread-Forming Screw	Tornillo Autorroscante	
10	●	-	-	1695001227	Molla	Ressort	
					Spring	Resorte	

Pos.	Class	Intervall	Customer	Partnumber	IDENTIFICATION (it)	IDENTIFICATION (fr)	Drawing
					IDENTIFICATION (en)	IDENTIFICACION (es)	
					Comment (it)	Comment (en)	
11	○	-	-	Normpart	Spina Elastica Coiled Spring Pin	Goupille Spirale Pasador Elastico Espiral	
12	●	-	1695654476	Pedaleria Pedal Unit	Groupe Pedale Grupo De Pedales		
13	○	-	-	Normpart	Disco Washer ISO 7089 6	Rondelle Arandela	
14	○	-	-	Normpart	Vite cilindrica esagonal Hex Socket Head Cap Screw ISO 4762 M6x10	Vis cyl SixPans Creux CHC Tornillo cilindrica hex	
F	○	-	-	1695042136	Cavetto Di Comando Cable control	Câble de commande Cable De Mando	
801	○	-	-	in work	Dispos Impianto Frenante braking system	Dispositif De Freinage Dispositivo De Frenado	

Pos.	Class	Intervall	Customer	Partnumber	IDENTIFICATION (it)	IDENTIFICATION (fr)	Drawing
					IDENTIFICATION (en)	IDENTIFICACION (es)	
					Comment (it)	Comment (en)	
1	●	-	-	1695042874	Motore A Corr.Altern.	Moteur Courant Alternatif	
					Alternating-Current Motor	Motor Corriente Alterna	
					230V - 1 ph - 50 Hz		
1*	●	-	-	1695043191	Motore A Corr.Altern.	Moteur Courant Alternatif	
					Alternating-Current Motor	Motor Corriente Alterna	
					110V - 1 ph -		
2	●	-	-	1695655620	Lamiera Di Acciaio	Tole D'acier	
					Steel Sheet	Chapa De Acero	
3	●	-	-	Normpart	Vite svasata esagonale	Vis tête fraisée six pans	
					Hex socket countrsk screw	Tornillo Avellanada Hex	
					ISO 10642 M8x12		
4	●	-	-	Normpart	Rondella piana	Rondelle plate	
					Plain Washer	Arandela plana	
					ISO 7093-2 5x20x1,5		
5	●	-	-	Normpart	Vite cilindrica esagonal	Vis cyl SixPans Creux CHC	
					Hex Socket Head Cap Screw	Tornillo cilindrica hex	
					ISO 4762 M5x16		
6	●	-	-	1695655627	Puleggia	Poulie	
					Pulley	Polea	
7	●	-	-	1695042883	Condensatore	Condenseur	
					Condenser	Condensador	
8	○	-	-	Normpart	Rondella piana	Rondelle plate	
					Plain Washer	Arandela plana	
					ISO 7093-2 6,5X18X1,5		
9	●	-	-	Normpart	Vite testa esagonale	Vis Tête Hexagonale	
					Hex Screw	Tornillo Cabeza Hex	
					ISO 4017 MA6x10		

Pos.	Class	Intervall	Customer	Partnumber	IDENTIFICATION (it)	IDENTIFICATION (fr)	Drawing
					IDENTIFICATION (en)	IDENTIFICACION (es)	
					Comment (it)	Comment (en)	
10	●	-	-	1695042409	Cinghia Di Trasmissione Drive Belt	Courroie D'entrainement Correa Motriz	<p>65108-04_Im</p>
801	○	-	1695655663	Motore Motor 230V - 1 ph - 50 Hz	Moteur Motor		
801*	○	-	1695655847	Serie Parti Parts Set 110 - 1 ph - 50/60 Hz	Jeu De Pieces Juego De Piezas		

Pos.	Class	Intervall	Customer	Partnumber	IDENTIFICATION (it)	IDENTIFICATION (fr)	Drawing
					IDENTIFICATION (en)	IDENTIFICACION (es)	
					Comment (it)	Comment (en)	
1	●	-	-	1695653503	Pezzo Stampato D Plastica	Piece Moulee En Plastique	
					Plastic Moulding	Pieza Form De Plastico	
2	●	-	-	1695653504	Espulsore	Ejecteur	
					Ejector	Expulsor	
3	●	-	-	1695653505	Pezzo Stampato D Plastica	Piece Moulee En Plastique	
					Plastic Moulding	Pieza Form De Plastico	
4	●	-	-	1695653509	Molla	Ressort	
					Spring	Resorte	
5	●	-	-	1695653506	Pezzo Stampato D Plastica	Piece Moulee En Plastique	
					Plastic Moulding	Pieza Form De Plastico	
6	●	-	-	1695653514	Leva	Levier	
					Lever	Palanca	
7	●	-	-	1695653502	Coperchio	Couvercle	
					Cover	Tapa	
8	●	-	-	Normpart	Vite Cilindrka	Vis Sans Tete	
					Headless Screw	Piton Roscado	
					ISO 4026 M4x8		
9	●	-	-	Normpart	Vite svasata esagonale	Vis tête fraisée six pans	
					Hex socket countrsk screw	Tornillo Avellanada Hex	
					EN 10642 m6x20		
10	●	-	-	1695654111	Assale	Axe	
					Axle	Eje	

Pos.	Class	Intervall	Customer	Partnumber	IDENTIFICATION (it)	IDENTIFICATION (fr)	Drawing
					IDENTIFICATION (en)	IDENTIFICACION (es)	
					Comment (it)	Comment (en)	
11	●	-	-	1695654333	Molla	Ressort	
					Spring	Resorte	
12	●	-	-	Normpart	Vite	Vis	
					Screw	Tornillo	
13	●	-	-	Normpart	Dado Esagonale basso	Écrou hex bas HM	
					Hex thin nut	Tuerca Hex Baja	
					ISO 8673 MA6		
14	●	-	-	Normpart	Vite Autofilettante	Vis Autotaraudeuse	
					Thread-Forming Screw	Tornillo Autorroscante	
					ISO 7049 3,9x13		
801	●	-	-	1695654782	Dispositivo Di Misura	Instrument De Mesure	
					Measuring Tool	Dispositivo De Medida	
802	●	-	-	1695600130	Kit Pezzi Di Ricambio	Jeu De Rechanges	
					Service kit	Juego De Repuestos	
803	●	-	-	1695654897	Potenziometro	Potentiometre	
					Potentiometer	Potenciometro	

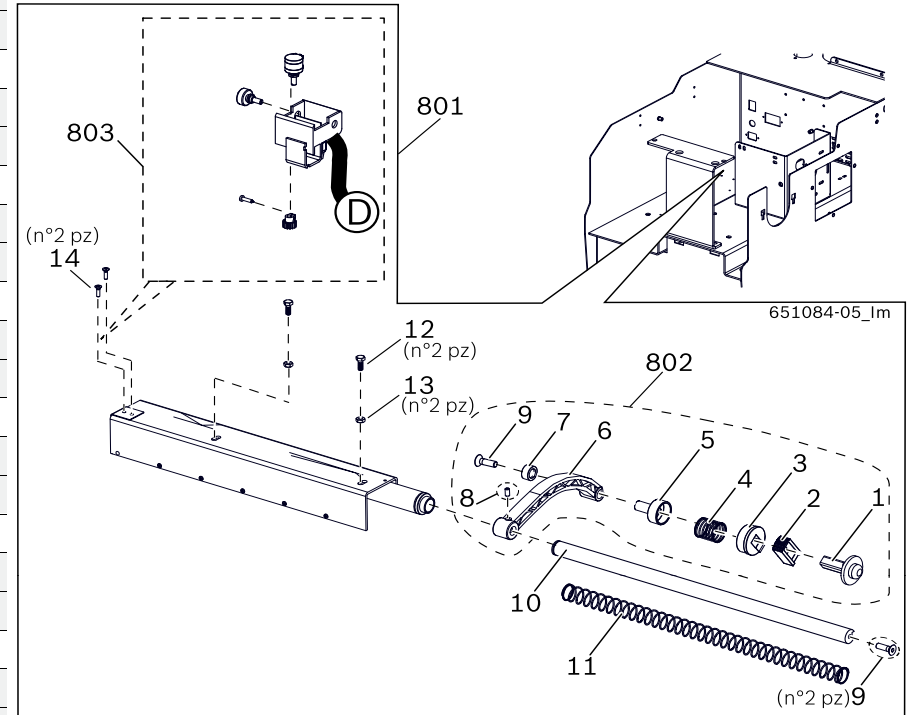

Pos.	Class	Intervall	Customer	Partnumber	IDENTIFICATION (it)	IDENTIFICATION (fr)	Drawing
					IDENTIFICATION (en)	IDENTIFICACION (es)	
					Comment (it)	Comment (en)	
1	●	-	-	1695601200	Boccola	Douille	
					Bushing	Casquillo	
2	●	-	-	1695600113	supporto basculante	Support oscillant	
					Self-aligning pad	soporte pendular	
3	●	-	-	Normpart	Vite Cilindrka	Vis Sans Tete	
					Headless Screw	Piton Roscado	
					ISO 4029 M8X8		
4	●	-	-	1695600400	Boccola	Douille	
					Bushing	Casquillo	
5	○	-	X	Normpart	Vite svasata esagonale	Vis tête fraisée six pans	
					Hex socket countrsk screw	Tornillo Avellanada Hex	
					ISO 10642 M5X40		
6	●	-	-	in work	Microinterruttore	Microcontacteur	
					Microswitch	Microinterruptor	
7	○	-	-	Normpart	Rondella Elastica	Rondelle élastique	
					Spring Lock Washer	Arandela elástica	
8	○	-	-	Normpart	Dado Esagonale	Ecrou Hex	
					Hex Nut	Tuerca Hex	
9	○	-	-	Normpart	Vite Autofilettante	Vis Autotaraudeuse	
					Thread-Forming Screw	Tornillo Autorroscante	
10	●	-	-	1695600047	Pezzo Stampato Plastica	Couverture de plastique	
					plastic covering	cubierta de plástico	
					Ral 9005		











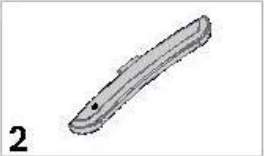















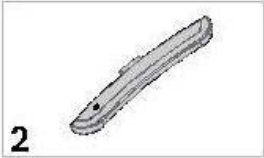

Pos.	Class	Intervall	Customer	Partnumber	IDENTIFICATION (it)	IDENTIFICATION (fr)	Drawing
					IDENTIFICATION (en)	IDENTIFICACION (es)	
					Comment (it)	Comment (en)	
E	1	-	-	1695654434	Barra Fotoelettrica	Barriere Photoelectrique	
					Photoelec. Light Barrier	Barrera De Luz	
F	1	-	-	1695655507	Cavo Elettriso	Cable	
					Cable	Cable	
G	1	-	-	1695654776	Rilevatore Di Percorrenza	Capteur De Deplacement	
					Displacement sensor	Registrador De Reorrido	
G*	1	-	-	1695654777	230 V		
					Rilevatore Di Percorrenza	Capteur De Deplacement	
G*	1	-	-	1695654777	Displacement sensor	Registrador De Reorrido	
					110 V		
C	1	-	-	1695654444	Cavo Elettriso	Cable	
					Cable	Cable	
Q	1	-	-	1695655367	Elettromagnete	Electro-Aimant	
					Electromagnet	Electroiman	
B	1	-	-	1695656727	Cavo	Câble	
					Cable	Cable	
H	1	-	-	1695653663	Interruttore	Commutateur	
					Switch	Interruptor	
L	1	-	-	1695655629	Set Di Cavi	Jeu De Cable	
					Cable Set	Juego De Cables	

651087-04\_lm

Pos.	Class	Intervall	Customer	Partnumber	IDENTIFICATION (it)	IDENTIFICATION (fr)	Drawing
					IDENTIFICATION (en)	IDENTIFICACION (es)	
					Comment (it)	Comment (en)	
1	ⓘ	-	X	1695652991	Alimentatore	Câble de puissance	           
					Power Cable	cable p.energía electr.	
2	●	-	X	1695654377	Contrappeso	Contrepoids	
					Counterweight	Contrapeso	
3	●	-	X	1695606500	Pinza	Tenaille	
					Pair Of Tongs	Tenazas	
4	ⓘ	-	X	1695602700	Calibro	Pied à coulisse	
					Caliper	Pie de rey	
5	ⓘ	-	X	1695629400	calibro	calibre	
					Gauge	calibre	
6	●	-	X	1695624800	Anello Di Gomma	Bague En Caoutchouc	
					Rubber Ring	Anillo De Goma	
7	●	-	X	1695656585	Leva	Levier	
					Lever	Palanca	
8	○	-	X	1695655338	Prolunga	Cordon Prolongateur	
					Extension Cable	Cordon Prolongador	
9	○	-	X	1695040641	Bullone A Occhio	Boulon A Oeillet	
					Eyebolt	Perno De Ojete	
10	ⓘ	-	X	Normpart	Tassello Di Spinta	Element De Pression	
					Pressure Element	Elemento De Presion	
					N° 3 pz		

651084-09\_Im

Pos.	Class	Intervall	Customer	Partnumber	IDENTIFICATION (it)	IDENTIFICATION (fr)	Drawing
					IDENTIFICATION (en)	IDENTIFICACION (es)	
					Comment (it)	Comment (en)	
11	●	-	X	Normpart	Vite testa esagonale	Vis Tête Hexagonale	
					Hex Screw	Tornillo Cabeza Hex	
					ISO 4017 MA8x70, n°3 pz		
12	○	-	X	Normpart	Rondella piana	Rondelle plate	
					Plain Washer	Arandela plana	
					ISO 7093-2 8,5x24x4, n°3 pz.		
							
							
							
							
							
							
							
							
							
							

651084-09\_lm

Date	Product	Editor	Modification
12.10.2012	ALL	Ruoff	Spare parts updated
04.04.2012	All	Benedettini	New grafic and spare parts
21.04.2011	All	Benedettini	New template
24.07.2012	SBM 135 A	Benedettini	New Spare parts



Sicam S.r.l.  
Tyre Equipments & Tools  
Via G. Corradini, 1  
42015 Correggio (RE)  
ITALY  
[www.sicam.it](http://www.sicam.it)

1 695 656 367 - 2012-10-12